

**SVEUČILIŠTE U ZAGREBU  
FAKULTET STROJARSTVA I BRODOGRADNJE**

**ANALIZA EKONOMSKI ODRŽIVOG POTENCIJALA  
OBNOVLJIVIH IZVORA U ENERGETICI MALTE**

**MAGISTARSKI RAD**

**Mentor:**  
**prof. dr.sc. Neven Duić**

**Ing. Antoine Busuttil**

**ZAGREB, 2008.**

**UNIVERSITY OF ZAGREB  
FACULTY OF MECHANICAL ENGINEERING  
AND NAVAL ARCHITECTURE**

**ANALYSIS OF ECONOMICALLY VIABLE POTENTIAL  
OF RENEWABLES IN MALTA ENERGY SYSTEM**

**SUSTAINABLE ENERGY ENGINEERING  
MASTERS OF SCIENCE  
FINAL THESIS**

**Supervisor:  
prof. dr.sc. Neven Duić**

**Ing. Antoine Busuttill**

**ZAGREB, 2008**

## PODACI ZA BIBLIOGRAFSKU KARTICU

<b>UDK:</b>	620.91
<b>Ključne riječi:</b>	Malta, energetske scenarije, H <sub>2</sub> RES, energija vjetra, vodik, financijska analiza, transport
<b>Znanstveno područje:</b>	TEHNIČKE ZNANOSTI
<b>Znanstveno polje:</b>	Strojarstvo
<b>Institucija u kojoj je rad izrađen:</b>	Fakultet strojarstva i brodogradnje Sveučilište u Zagrebu
<b>Voditelj rada:</b>	prof. dr. sc. Neven Duić
<b>Broj stranica:</b>	128
<b>Broj slika:</b>	72
<b>Broj tablica:</b>	30
<b>Broj korištenih bibliografskih jedinica:</b>	106
<b>Datum obrane:</b>	4. travnja 2008.
<b>Povjerenstvo:</b>	dr.sc. Srećko Švaić, redoviti profesor – predsjednik povjerenstva dr.sc. Neven Duić, izvanredni profesor – voditelj magistarskog rada dr.sc. Branka Jelavić, EIHP – članica povjerenstva
<b>Institucija u kojoj je rad pohranjen:</b>	Fakultet strojarstva i brodogradnje Sveučilište u Zagrebu

## DATA FOR BIBLIOGRAPHIC CARD

**UDK:** 620.91

**Key words:** Malta, Energy Scenarios, H<sub>2</sub>RES, Wind Energy, Hydrogen Storage, Financial Analysis, Fuel for Transport.

**Scientific scope:** TECHNICAL SCIENCES

**Scientific field:** Mechanical Engineering

**Institution at which work has been made:** Faculty of Mechanical Engineering and Naval Architecture  
University of Zagreb

**Advisor:** prof. dr. sc. Neven Duić

**Number of pages:** 128

**Number of figures:** 72

**Number of tables:** 30

**Number of titles listed in references:** 106

**Date of presentation:** 4<sup>th</sup> of April 2008

**Committee:** prof. dr.sc. Srećko Švaić - chairman of the commission  
prof. dr.sc. Neven Duić – thesis supervisor  
dr.sc. Branka Jelavić, EIHP – member of the commission

**Institution at which work is filed:** Faculty of Mechanical Engineering and Naval Architecture  
University of Zagreb



Zagreb, 06.03.2006.

## Zadatak za magistarski rad

Kandidat: **Antoine Busuttil, dipl.ing.**

Naslov: **Analiza ekonomski održivog potencijala obnovljivih izvora energije u energetsom sustavu Malte**

Sadržaj zadatka:

U zadatku će se primjenom metodologija energetske planiranja analizirati ekonomski održiv potencijal obnovljivih izvora energije (OIE) u energetsom sustavu Malte. Posebno će se naglasiti integriranje obnovljivih izvora energije i sustava vodika koji se zasnivaju na gorivim ćelijama (FC/H<sub>2</sub>), uzimajući u obzir njihov potencijal ublažavanja problema stakleničnih plinova.

U slučaju Malte primijenit će se takozvana RenewIslands metodologija za optimiranje sustava RES/FC/H<sub>2</sub> na otocima i udaljenim regijama, razrađena u istoimenom projektu. Metodološki pristup uključuje sljedeće četiri etape: utvrditi potrebe, utvrditi resurse, osmisliti scenarije s tehnologijama koje mogu koristiti dostupne resurse u cilju zadovoljavanja potreba i, na kraju, modeliranje scenarija.

U prve dvije etape prikupit će se svi dostupni i potrebni podatci (potrošnja i proizvodnja električne energije, potražnja za toplinom, proizvodnja i potražnja vode, emisije stakleničnih plinova, podatci o vremenu, itd.). Prikupljeni podatci će također sadržavati i pregled budućih planova, predloženih strategija i mjera, kao i dokumente poput Akcijskog plana o promjeni klime, Prvog nacionalnog priopćenja Malte o Okvirnoj konvenciji Ujedinjenih naroda o promjeni klime, pregled literature i nacionalnog zakonodavstva. Prikupljeni podatci bit će analizirani u trećoj etapi i poslužiti će u osmišljavanju tri scenarija vezanih uz primjenu obnovljivih izvora energije sve do 2025. godine.

Prvi scenarij će biti referentni scenarij koji odražava razvojni proces rukovođen politikom lokalnih vlasti kao i sklonostima tržišta. Drugi scenarij će pokušati udovoljiti cilju od 5% električne energije iz obnovljivih izvora energije koji je postavljen u Pristupnom ugovoru Direktive Europske unije o promicanju proizvodnje električne energije iz obnovljivih izvora. Treći scenarij će uzeti u obzir mjere za smanjenje emisije stakleničnih plinova u transportnom sektoru koje su predložene u malteškom Akcijskom planu o promjeni klime. On će omogućiti trenutno uvođenje do 30% intermitentnih obnovljivih izvora i proizvodnje vodika iz energije vjetra i sunca, zadovoljavajući na taj način 5% potražnje za energijom u području transporta u 2015. godini i 10% u 2025. godini.

Modeliranje svih scenarija provest će se pomoću kompjutorskog modela H<sub>2</sub>RES koji će biti poboljšani modulom financijske analize. Provest će se gospodarska analiza svih scenarija, uključujući utjecaj financijskih dokumenata Protokola iz Kyota.

Na kraju će se provesti rasprava o rezultatima i bit će predočeni zaključci zajedno s preporukama i smjernicama za budući razvoj.

Zadatak zadan: 18. 04. 2006.

Rad predan:

Mentor:

Doc.dr.sc. Neven Duić



Predsjednik Odbora za  
poslijediplomske studije:

Prof.dr.sc. Tomislav Filetin

Voditelj projekta:

Prof.dr.sc. Tonko Čurko



Zagreb, 06-03-2006.

## Master Thesis Proposal

Candidate: **Antoine Busuttil, dipl.ing.**

Title: **Analysis of economically viable potential of renewables in Malta energy system**

Thesis Contents:

The thesis will analyse the economically viable potential of renewable energy sources (RES) in Malta energy system by applying methodologies of energy planning. Special emphasis will be put on integrating RES and fuel cell based hydrogen systems (FC/H<sub>2</sub>) by taking into account their greenhouse gas mitigation potential.

The methodology for optimising RES/FC/H<sub>2</sub> systems in islands and remote regions devised by the project RenewIslands, the so called RenewIslands methodology, will be adopted for the case of Malta. A four step approach of the methodology includes: mapping the needs, mapping the resources, devising scenarios with technologies that can use available resources to meet needs and finally, modelling the scenarios.

Through the first two steps, all available and needed data will be collected (electricity consumption and production, heat demand, water demand and production, greenhouse gas emissions, weather data, etc). The collected data will also include the review of future development plans, proposed policies and measures and documents like Action Plan on climate change, The First National Communication of Malta to UNFCCC, a survey of literature and national legislation. The collected data will be analysed in the third step and they will serve for devising three scenarios concerning the RES utilization up to the year 2025.

The first scenario will be the Business as Usual Scenario which reflects a development process that is guided by existing local government policies and by the preferences of the marketplace. The second scenario will strive to meet the target of 5% of electricity from renewables set in the Accession Treaty of EU Directive on the promotion of electricity produced from renewable energy sources. The third scenario will take into account measures for greenhouse gas reduction in transport sector proposed in Malta's Action Plan on climate change. It will include 30% of instantaneous penetration of intermittent renewables and hydrogen production from wind and solar sources satisfying the 5% of transport energy demand in 2015 and 10% in 2025.

The modelling of all scenarios will be done by H<sub>2</sub>RES computer model which will be upgraded with the financial analysis module. The economic analysis of all scenarios will be provided, including the influence of Kyoto protocol financial instruments.

Finally, all results will be discussed and conclusions will be presented together with recommendations and guidelines for the future development.

Thesis proposed: 18. 04. 2006.

Thesis submitted:

Supervisor:

  
Doc.dr.sc. Neven Duić

Chairman of Committee for  
postgraduate studies:

  
Prof.dr.sc. Tomislav Filetin

Project Director:

  
Prof.dr.sc. Tonko Ćurko

## ACKNOWLEDGEMENTS

It is my pleasure to thank the many people who made this thesis possible.

First of all, this work would not have been possible without the support and encouragement of my supervisor Goran Krajačić, dipl. ing and my mentor prof. dr. sc Neven Duić both from the Department of Energy, Power, Engineering and Environment Faculty of Mechanical Engineering and Naval Architecture, University of Zagreb, Croatia. They have been both abundantly demanding yet helpful and assisted me in numerous ways in understanding, correcting and presenting my papers and thesis from the very start till the very end. They provided encouragement, sound advice, good teaching, and lots of good ideas. I would have been lost without them.

I wish to thank my best friends Lawrence Deguara, Ing. Keith Chetcuti and Ing. Rueben Mifsud for helping me get through the difficult times, and for all the emotional support, entertainment, and caring they provided. Thanks also to the rest of my friends, Joseph, Samuel, Silvan, Carmelo, Melvin and the rest of the endless list of my friends on whom I rely.

I would like to thank several of my friends for helping with the preparation of this thesis, supporting me during my stay in Croatia and throughout my life. Ivan Majce and Raj being my best course colleagues, Damir my friend in Croatia, Mario, Stefania and Lara. I thank you all. Special thanks also goes to Malta weather services and Enemalta for providing me with valuable data.

Lastly, and most importantly, I wish to thank my entire extended family on whose constant encouragement and love I have relied throughout my life and time during my MSc studies. They raised me, supported me, taught me, and loved me. Marion, your continuous help and careness was fundamental, Audrey I am grateful to all your listening and mum and dad, you were there, all the time, endless understanding, patience and encouragement when it was most required. And to you my little girls Arianne, Samira and Keira, you bring me a smile when I mostly need it.

I dedicate all this work to you.

Preface.....	VIII
Sažetak .....	IX
Abstract .....	X
Symbols.....	XI
Abbreviaitions.....	XIII
List of Illustrations .....	XV
List of Tables .....	XVII
1. Introduction.....	1
1.1. Background .....	1
1.2. Recent and most interesting findings connected to thesis.....	3
1.2.1. The Fossil Fuel Epoch.....	3
1.2.2. Renewable Energy Sources in Islands .....	3
1.2.3. The Hydrogen Era .....	3
1.3. Hypothesis.....	5
1.4. What are the achieved results.....	5
2. Methodology .....	6
2.1. Data Collection and Analysis.....	6
2.2. Predicting the growth rate and future load demand.....	8
2.3. Technology overview and status.....	8
2.3.1. Wind Energy .....	8
2.3.2. Solar .....	11
2.3.3. Hydrogen.....	13
2.4. Methodology and Simulation model.....	21
2.4.1. RenewIslands methodology .....	21
2.4.2. H <sub>2</sub> RES computer model .....	30
2.5. The financial approach.....	38
2.6. Kyoto Protocol .....	38
3. Description and Overview of the Malta Case.....	40
3.1.1. Population .....	40
3.1.2. Climate .....	40
3.1.3. Agriculture and fisheries.....	41
3.1.4. Economy .....	42
3.1.5. Industry .....	42
3.1.6. Energy .....	42
3.2. Malta's Power system .....	43
3.2.1. Delimara Power Station .....	44
3.2.2. Marsa Power Station .....	45
3.2.3. Load profile.....	46
3.3. Data Collection and Analysis.....	46
3.3.1. Malta load growth rate and future load demand.....	49
3.3.2. Analysing NAP predictions.....	50
3.3.3. Rate of growth of transport and Hydrogen load for transport.....	52
3.3.4. Current Price of Electricity .....	56
3.3.5. Carbon dioxide emissions .....	57
3.4. Wind Conditions in Malta.....	59
3.4.1. Analysis of the obtained simulated Wind data.....	60
3.4.2. Evaluation of wind data at Luqa .....	64
3.4.3. Analysis of results from previous authorities' measurements .....	65
3.4.4. Ideal Sites and availability of sites.....	69
3.5. Solar Conditions in Malta .....	71
3.5.1. Analysis of the obtained simulated Solar data.....	71



3.5.2.	Evaluation of the solar data.....	77
3.5.3.	Ideal Sites and availability of sites.....	78
3.6.	Hydrogen Energy Potential in Malta .....	79
3.6.1.	Status of the technology in Malta. ....	79
3.7.	RenewIslands Methodology applied to Malta .....	80
3.7.1.	Mapping the needs .....	80
3.7.2.	Mapping the resources .....	81
3.7.3.	Modelling the scenarios .....	86
3.8.	Calculations, logic and conditions. ....	87
3.8.1.	Scenario 1: Business as usual scenario. ....	87
3.8.2.	Scenario 2: Fossil Fuel and low level penetration of wind and solar scenario. ....	90
3.8.3.	Scenario 3: Fossil Fuel, RE & Hydrogen storage scenario for the transport sector ..	91
3.9.	Financial Analysis.....	93
3.10.	Malta obligations under Kyoto Protocol.....	95
4.	Results.....	99
4.1.	Scenario Results.....	99
4.1.1.	Scenario 1: Business as usual scenario. ....	99
4.1.2.	Scenario 2: Fossil Fuel and low level penetration of wind and solar scenario. ....	101
4.1.3.	Scenario 3: Fossil Fuel, RE & Hydrogen storage scenario for the transport sector	105
4.2.	Net Present Value .....	109
4.3.	CDM and its effect on electricity.....	110
5.	Conclusion .....	113
5.1.	General Evidences.....	113
5.2.	How hypothesis was proved .....	116
5.3.	Conclusions.....	116
	References.....	120
	Životopis .....	128
	Biography.....	128

## **Preface**

Whilst that the availability of electricity by itself is not a nostrum for the economic and social problems facing the majority of Small Island Developing States (SIDS), the secure supply of electricity is nevertheless believed to be a necessary requirement for socio-economic growth. A yoke between energy postulate and Gross Domestic Product (GDP) is well acknowledged and has to be seriously addressed.

The purpose of this thesis is to develop and present a more unified and generally applicable approach for assessing the technical and economical feasibility of isolated power supply systems with Renewable Energy sources (RES) and evaluate alternative scenarios for the sustainable management of the energy system in the Island of Malta. The study tackles holistically the penetration of different energy producing units, such as renewable energy units, in particular wind and solar, to suit the islands' necessity. Diversified intelligent load control as a way to significantly increase renewable energy penetration and cut diesel fuel consumption, whilst maintaining system stability. The study also introduces hydrogen as an energy vector. This is used to give a valuable contribution in the reduction of use of fossil fuels. However it is also used in times of peak demand.

From the Demand and management side, the load growth is analysed and compared with energy demand emergence, thus giving an indication of what future energy requirements, thus investments, should look like.

The need for an attractive legislative and financing framework is finally considered as the governments' role of promoting the efficient use of energy and the promotion of alternative energy resources whilst adhering to international protocols and obligations. This will reduce fuel imports which are a great drain and a significant constraint on development - it crowd out vital capital and social expenditures and inhibit the achievement of much needed growth.

This study was performed in view of the current International work and efforts to promote and disseminate Renewable Energy Sources (RES) on a larger scale, in order to achieve 100% RES energy supply on Islands in Europe, in the Pacific and in particular in the Caribbean region. An example of such a mechanism is the Forum for Renewable Energy Islands (FREI) targeting to achieve 100% of their energy supply from RES of selected island states. This will also incorporate transportation later on [1]. It also aims to integrate RES to cope with tourism peak necessities and water desalination processes to cover the demand, especially during the summer months. It is the only reasonable option in the framework of island strategies in favour of sustainable development, and it should complement the generalised development of measures in favour of the efficient use of energy.

The results succeed to support the applicability of RES in the energy system of Malta and although there are of course many obstacles which impede the development of energy management, all in all it proves that the advantages outweigh the disadvantages.

## **Sažetak**

S apsolutnom ovisnošću o uvoznim fosilnim gorivima i bez povezanosti na europske ili afričke električne mreže, elektroenergetski sustav Malte je izrazito osjetljiv te je pod utjecajem mnogih internacionalnih čimbenika. U svrhu smanjenja ove ovisnosti važnost integracije drugih izvora energije u energetske sustav Malte je od najvećeg značenja. Smještena u centru Sredozemlja, Malta može puno dobiti od iskorištavanja velikog potencijala solarne energije te korištenje ostalih potencijala obnovljivih izvora kao što su energija vjetra, otpad od biomase, deponijski plinovi i postrojenja za obradu otpadnih voda može biti vrlo poticajno. Integriranje ovakvih tehnologija, zajedno s upravljanjem potrošnjom će pored povećanja sigurnosti energetske dobave pomoći i pri smanjivanju CO<sub>2</sub> emisija u kontroliranju globalnog zatopljenja. Pametno investiranje može dovesti i do stvarnih financijskih ušteda primjenjujući programe kao što je europski program trgovanja emisijama koji nadalje promovira tu kontrole.

Ova studija nastoji istražiti kretanje potrošnje električne energije u državi u funkcije njene klime i sezonske industrije kao što je turizam. To dovodi do projekcija povećanja potrošnje prema kojima treba planirati investicije. U ovoj fazi predložena su tri scenarija koji se kreću od scenarija s fosilnim gorivima, do scenarija u kojima se uvode već “stasale” tehnologije za iskorištavanje obnovljivih izvora energije, kao što su vjetrotroelektrane i fotonaponske ćelije, sve do scenarija gdje se u budućnosti uvodi vodik kao zamjena određenog postotka goriva u transportu, a gdje se višak koristi za proizvodnju električne energije. Studija kvantitativno prikazuje troškove i investicije dok isto razmatra utjecaj europskih obveza i njihovih posljedica.

Izvedena analiza pokazuje da je situacija na Malti poprilično kritična s mnogo stvari koje trebaju biti napravljene u kratkom vremenu. Povećanje cijene električne energije je neizbježno, međutim, kombiniranjem tehnologija, iskorištavanjem potencijala na otoku i shvaćanjem odgovornosti svakog pojedinca u sustavu, će svakako dovesti do bolje situacije. Dobiveni rezultati su uspoređeni i prikazani u radu.

Ključne riječi: Malta, energetske scenariji, H<sub>2</sub>RES, energija vjetra, spremnik vodika, financijska analiza, gorivo za transport

## **Abstract**

With an absolute dependence on imported fossil fuels, and no interconnection to the European or African electrical grid as yet, Malta's energy system is a fragile one being a factor of a lot of international factors. In order to reduce this dependence, the importance to integrate other sources of energy to our system is of utmost importance. Situated in the centre of the Mediterranean, Malta gains from high solar energy and the potential of other renewable sources such as wind, biomass wastes, landfill gases and sewage treatment plants are very encouraging. The integration of such technologies, together with demand side management, will, apart from increasing our security of supply help reduce CO<sub>2</sub> emissions in controlling global warming. Intelligent investment can also lead to substantial financial savings by applying schemes such as European trading scheme which further promote this control.

This study aims to investigate the electrical load tendencies of the country as a function of its climate and seasonal industries such as tourism. This eventually leads a projected load growth from which investments have to be made. At this stage, three investment scenarios are proposed varying from a fossil fuel scenario, to a scenario integrating "mature" renewable energy technologies such as wind and photovoltaic to a future scenario where hydrogen is being produced to cover a certain percentage of fuel for transport, the excess being used for electricity. The study quantifies expenses and investments whilst also considers the effect of European obligations and consequences.

The performed analysis shows that the situation in Malta is quite critical with a lot that has to be done in a short time. A price increase in electricity is inevitable, however, combining technology, utilising the potential of the island and understanding the responsibility of each individual in the system, will surely lead to a better situation. The results obtained are compared and presented in the thesis.

Key words: Malta, Energy Scenarios, H2RES, Wind Energy, Hydrogen Storage, Financial Analysis, Fuel for Transport.

## Symbols

<i>SYMBOL</i>	<i>DESCRIPTION</i>	<i>UNIT</i>
$U_z$	wind speed at specified height $z$	m/s
$z$	height	m
$u^*$	friction velocity	m/s
$z_0$	roughness length	m
$\kappa$	von Karman constant	-
$U_x$	wind speed at specified height $x$	m/s
$Z_x$	height	m
$U_0$	known wind speed at $Z_o$	m/s
$Z_o$	Reference height	m
$\alpha$	surface roughness exponent constant	-
$n$	integer representing number of hours	-
$E^n_{H_2}$	energy accumulated in hydrogen storage in hour $n$	J
$E^{n-1}_{H_2}$	energy accumulated in hydrogen storage in hour $n - 1$	J
$E_{FC}$	energy produced during one hour by a fuel cell	J
$\mu_{FC}$	efficiency of fuel cell	%
$\mu_{el}$	efficiency of electrolyser	%
$E_{H_2,load}$	hydrogen load	J
$E_{el}$	energy consumed in electrolysing water	J
$t_{H_2,sec}$	a set number of hours of hydrogen supply	h
$E_{load}$	load demand	J
$E_{I,t}$	intermittent renewable energy taken by the system	J
$E_T$	energy output from the hydro turbines	J
$E_{bat,out}$	energy output from the batteries	J
$E_P$	energy consumed by pumping water	J
$E_{bat,in}$	energy consumed by charging batteries	J
$E_D$	energy output of the diesel blocks in use at that moment	J
$\varphi_I$	intermittent limit	%
$E_{I,pot}$	intermittent potential	J
$E_{W,pot}$	wind potential	J
$E_{PV,pot}$	Solar PV potential	J
$R_j$	required return or discount rate for asset $j$	%
$R_f$	risk-free rate of return	%
$R_m$	return to a broadly diversified market portfolio	%
$\beta$	statistically derived covariance term relating the variability of asset $j$ to the variability of the broadly diversified market portfolio	-
$j$	asset	-

$P_k$	peak power installed	W
$r_p$	system performance ratio	-
$H_{h,I}$	the monthly or yearly average of daily global irradiation on the horizontal or inclined surface	kWh/m <sup>2</sup> /day
$E$	yearly potential electrical energy generation	J
$H_2 \text{ cost}_{trans}$	yearly cost of hydrogen for transport	€
$\text{payment}_{electrolyser}$	yearly payment for installed electrolyser	€
$\text{payment}_{storage}$	yearly payment for installed hydrogen storage	€
$H_2 \text{ electrolysed}_{tot}$	yearly total of hydrogen electrolysed	Nm <sup>3</sup>
$H_2 \text{ electrolysed}_{trans}$	yearly amount of hydrogen electrolysed for transport	Nm <sup>3</sup>
$H_2 \text{ utilised}_{trans}$	yearly amount of hydrogen utilised for transport	Nm <sup>3</sup>
$\text{Elec}_{H_2 \text{ cost}}$	yearly cost of electricity produced from hydrogen	€
$\text{payment}_{electrolyser}$	yearly payment for installed electrolyser	€
$\text{payment}_{fuelcell}$	yearly payment for installed fuel cells	€
$H_2 \text{ fuelcell}_{tot}$	yearly total hydrogen utilised by fuel cell for electricity conversion	Nm <sup>3</sup>
$H_2 \text{ stored}_{tot}$	yearly total amount of hydrogen stored	Nm <sup>3</sup>
$G$	Global Horizontal solar radiation	kWh/m <sup>2</sup> /day
$H_0$	Extraterrestrial radiation	kWh/m <sup>2</sup> /day
$G/H_0$	Clearness Index	-

## **Abbreviations**

a-Si:	Amorphous Silicon
BAU:	Business as usual
CCGT:	Combined Cycle Gas Turbine
CDM:	Clean Development mechanism
c€:	Euro cents
CERs:	Certified Emission Reductions
CdTe:	Cadmium Telluride
CuInSe <sub>2</sub> :	Copper Indium Diselenide
€:	Euro
EAU:	Emission allowance unit
EC:	Energy carriers
EC:	European community
EMC:	Enemalta corporation
ERU:	Emission Reduction Units
ETS:	European trading scheme
EU:	European Union
FC:	Fuel Cells
FREI:	Forum for Renewable Energy Islands
GDP:	Gross Domestic Product
GJ:	Giga Joules
H <sub>2</sub> :	Hydrogen
IES:	Institute for environment and sustainability
JI:	Joint implementation
km:	Kilometres
km <sup>2</sup> :	Squared kilometres
KOH:	Potassium hydroxide
kW:	kilo watt
kWh:	kilo watt hour
LDC:	Load duration curves
Lm:	Maltese Lira
m:	metres
MEPA:	Malta Environment and Planning authority
MIA:	Malta International Airport
MMA:	Malta Maritime Authority
MRA:	Malta Resources authority
MSL:	Mean sea level
MTA:	Malta Tourism authority
MWh:	Mega watt hour
m/s:	metres per second
NAP:	National allocation plan
NGASE:	Natural-Gas-Assisted-Steam Electrolysis
Nm <sup>3</sup> :	Neuton metre cubed
OECD:	Organisation for Economic Co-operation and Development
PEMFC:	Polymer electrolyte membrane FC
PV:	Photo Voltaic
RES:	Renewable Energy Sources
SAPS:	Stand alone power supply systems
SIDS:	Small Island Developing States

SOFC: Solid oxide fuel cell  
VRT: Vehicle roadworthiness test  
WT: Wind Turbine



## List of Illustrations

Figure 1: An integrated energy system including hydrogen as envisaged by [13].	4
Figure 2: Temperature variations across the globe by NASA - July 1984 [22].	9
Figure 3: The promising offshore wind farm idea [26].	11
Figure 4: Hydrogen production processes as envisaged by [31] in year 2002	15
Figure 5: The six basic hydrogen storage methods and phenomena [34].	19
Figure 6: Typical hydrogen cost produced from different technologies [35].	20
Figure 7: Future potential cost of electrolytic hydrogen [36].	20
Figure 8: Scheme of H <sub>2</sub> RES 2.5 model.	30
Figure 9: Actual data used for wind turbine outputs.	33
Figure 10: The main islands in the Maltese archipelago.	41
Figure 11: Efficiencies of individual units at Marsa and Delimara Power Stations [53].	44
Figure 12: Generated power up to year 2005.	46
Figure 13: Summer and winter peaks up to year 2005.	47
Figure 14: Base year load variation	48
Figure 15: Base year 2002 with projected load growth applied until year 2025	49
Figure 16: Base projection of electricity demand (from correlation) [53].	51
Figure 17: Growth in energy consumption between 1990 and 2000 [55].	53
Figure 18: Estimated load growth in kilometres travelled.	54
Figure 19: Projected increase in hydrogen fuel use	55
Figure 20: Hydrogen production necessary in order to cover projected hydrogen load.	55
Figure 21: CO <sub>2</sub> emission trends for 1990-2000.	58
Figure 22: GHG emission trends for different gases 1990-2000.	58
Figure 23: CO <sub>2</sub> emissions from electrical power generation, transport and energy generated.	59
Figure 24: Simulated wind resource data.	60
Figure 25: Daily wind speed variation for the whole year.	61
Figure 26: Wind speed monthly averages.	61
Figure 27: Monthly wind speed profile.	62
Figure 28: Wind speed duration curve.	62
Figure 29: Wind speed distribution function	63
Figure 30: Frequency of the simulated wind directions.	63
Figure 31: European wind resources over open sea [63].	67
Figure 32: Wind rose at Malta International Airport for the summer period of operation [64]	68
Figure 33: Wind rose at Malta International Airport for the annual period of operation [64].	68
Figure 34: Onshore wind potential sites.	69
Figure 35: Shallow (<20m) offshore sites suitable for wind energy production [66]	70
Figure 36: Simulated data for solar radiation.	71
Figure 37: Daily global solar radiation	71
Figure 38: Monthly averages	72
Figure 39: Monthly global solar radiation	72
Figure 40: Solar duration curve	73
Figure 41: Yearly sum of the electricity generated by a 1 kWp PV.	74
Figure 42: Photovoltaic solar potential in some of the European countries [70].	76
Figure 43: A colour reference diagram.	76
Figure 44: Output from panel for horizontal irradiation; yearly average of 5423 Wh/m <sup>2</sup> /day.	76
Figure 45: Probability versus daily horizontal irradiation for different months.	77
Figure 46: Optimal monthly inclination leading to a 32 degrees yearly optimal.	77
Figure 47: Tilt and azimuth angle	78
Figure 48: OPEC annual average crude oil price per barrel [77][78].	90

Figure 49: Clean development mechanism [84].	96
Figure 50: CO <sub>2</sub> Price evolution in EU ETS (Point Carbon)	97
Figure 51: Blocks needed to be installed in a BAU N-1 Scenario.	99
Figure 52: Supplying demand for a BAU N-1 scenario according to projected growth	100
Figure 53: Financial analysis results of a BAU N-1 scenario based on projected values.	101
Figure 54: Installed power in a scenario 2 according to projected load growth	102
Figure 55: All installed scenario 2.	103
Figure 56: Supplying demand 2 <sup>nd</sup> scenario	104
Figure 57: Intermittent potential for scenario 2.	104
Figure 58: Financial analysis results of second scenario based on projected values.	105
Figure 59: Installed blocks exc. fossil fuel in a scenario 3 according to projected load growth.	106
Figure 60: All installed scenario 3.	107
Figure 61: Supplying Demand 3 <sup>rd</sup> scenario.	107
Figure 62: Intermittent potential for scenario 3.	108
Figure 63: Financial analysis results of third scenario based on projected values.	108
Figure 64: Present value of all the investments compared as at year 2005	110
Figure 65: Effect of emission allowances on electricity price scenario 1 at 15€/tCO <sub>2</sub> .	111
Figure 66: Effect of emission allowances on electricity price scenario 2 at 15€/tCO <sub>2</sub> .	111
Figure 67: Effect of emission allowances on electricity price scenario 3 at 15€/tCO <sub>2</sub> .	112
Figure 68: Produced carbon dioxide from electricity generation only under different scenarios.	113
Figure 69: Saved carbon dioxide emission under different scenarios.	114
Figure 70: CO <sub>2</sub> to be covered under different scenarios.	114
Figure 71: Percentage price increase under different Scenarios at 15€/tCO <sub>2</sub> .	115
Figure 72: Electricity cost with EAU cost at 15€ per tonne of CO <sub>2</sub> above NAP limit.	115

## List of Tables

Table 1: Types of available fuel cells [30].....	15
Table 2: Electrolysis technologies compared [32].....	16
Table 3: General mapping of the needs .....	23
Table 4: Mapping the island/remote area resources.....	23
Table 5: Potential energy carriers (EC).....	24
Table 6: Potential delivering technologies.....	25
Table 7: Potential storage technologies .....	27
Table 8: Integration of flows.....	28
Table 9: Delimara power generating units [52]. .....	44
Table 10: Marsa power generating units [52]. .....	45
Table 11: Electricity demand, GDP and time. (Projections in italics) [53] .....	51
Table 12: Final energy consumption by transport [55]. .....	52
Table 13: Distribution of final energy consumption in 2000 [55]. .....	53
Table 14: Use of transport fuels in Malta 2003 [56]. .....	54
Table 15: Emissions of CO <sub>2</sub> during last three years from the two power stations [52]. .....	58
Table 16: Typical surface roughness exponents. ....	64
Table 17: Average monthly wind speed for different yearly periods [62]. .....	66
Table 18: Description of the clearness index of the sky over Malta [68] .....	75
Table 19: Mapping Malta community needs .....	80
Table 20: Mapping Malta available resources .....	81
Table 21: Potential energy carriers (EC).....	82
Table 22: Potential delivering technologies.....	82
Table 23: Potential storage technologies .....	84
Table 24: Integration of flows.....	85
Table 25: Comparison of used data for existing and new plants .....	89
Table 26: Carbon dioxide emissions [89] .....	98
Table 27: Scheme of installed fossil fuel blocks according to simulations .....	100
Table 28: Scheme of Installed FF Blocks, WT and PV panels according to simulations. ....	102
Table 29: Scheme of installed fossil fuel blocks according to simulations, 3 <sup>rd</sup> scenario.....	106
Table 30: WT, PV panels, electrolyser, FC and hydrogen storage according to simulations.....	107

# **1. Introduction**

Energy scenarios provide a structure for understanding and exploring different future energy perspectives. In view of the alarming atmospheric changes, the term “Sustainable” was introduced in order to describe attitudes aiming to address our needs without compromising future ones. Sustainable energy scenarios usually impose a set of functions in order to reach the necessary objectives. These are somehow always related to a transition from fossil to adoption of environmentally friendly behaviour patterns energy sources which in turn have to be enforced by policies and legislations in order to achieve the required results.

## **1.1. Background**

Many island power systems are powered by oversized diesel generators or long underwater cables, which results in greater operating costs or losses than large interconnected grid systems. It is therefore desirable to integrate renewable energy sources into these mini grids.

Nearly all islands in the world are totally dependent on expensive and environmentally problematic fossil fuels for their energy needs. But islands have a unique potential for renewable energy [2], [3] and [4]- a competitive economic situation for renewable energy technologies, and energy resources. Therefore islands are very important and interesting when it comes to the promotion of sustainable energy system. Managing energy for the island is quite difficult as they are isolated geographically and supply of security is always the concern. It is due to this fact that harnessing sustainable energy for the island limit to the best locally available energy resources, and is the best way of designing the energy system. The best resources component of the energy supply would then be the renewable energy – solar and wind. In most cases the hydro energy seems virtually impossible to take consideration for island.

Most of the island generation systems are managed by small monopolistic electricity distribution companies thus reluctant to change the existing situation since the extra cost of local energy production is totally covered by the government. It follows that island inhabitants pay the energy unit at the subsidised price. The government pays the difference between the cost of energy and the final user bill to the distributor. This mechanism produces high energy consumption and inefficiency and it is the reason why distributors are definitely against a change of scenario particularly if energy saving measures and renewable energies are being proposed.

The need to provide the islands with a framework for future development in renewable energies was already highlighted in the European Commission's White Paper on Renewable Energy Sources [1], United Nations Conference on Islands and Small Island States (Barbados 94) and the 1st European Conference on Island Sustainable Development. The European Island Agenda highlights "the non-renewable energy sources as provisional solutions, inadequate to solve in the long term the energy problems of the islands".

Adequate energy planning on islands, together with change in policies [5], [6] and laws can partially solve this problem by reducing energy needs, peak loads, atmospheric emissions and by introducing renewable energies. The tourist nature of the island (large influx during summer time) together with the favourable wind conditions generally experienced on islands gives a unique opportunity of applying direct solar and wind technologies to meet tourist and residential needs respectively. The basic consumption of the energy is usually a function related to the population of the island, the tourism industry, and the climatic variation.

Energy management deals about efficient use and production of energy and the selection of technology. The study of the energy management is carried out using system approach. It keeps significant advantages for the planner, manager, designer and the whole community that uses the energy. The approach of the energy system study may vary from place to place and also in the available technology and tools. Basically it analyzes the system component playing role in power generation and their interrelatedness. In this sense, the study of the energy management considering sustainable energy is promising as it associates environmentally friendly technology, economic, and sustainable in nature.

In this study on the Maltese archipelago, the analysis of different scenarios are analysed and presented in order to integrate RES up to a sustainable limit thus reducing losses, increase renewable energy penetration and cut fossil fuel consumption, whilst maintaining system stability and increasing job opportunities. (Distributed intelligent load control is a technology that allows stand alone power systems to use one or many standard grid connected wind turbines) [7]. Energy storage methods and possibilities are also analysed to avoid loss of available energy and ride through periods of generation deficit.

## **1.2. Recent and most interesting findings connected to thesis**

### **1.2.1. The Fossil Fuel Epoch**

With fossil fuelled power plants reaching higher efficiencies and the introduction of poly-generation systems in order to better utilise the generating plants, one could still assume that the fossil fuelled power generating plants have reached a mature stage and only the introduction such as poly generation or the integration of other technologies such as fuel cell will increase the overall plant efficiency [8]. More and more, this limit is being inhibited by the awareness that in some way or another we are approaching faster and faster to the peak i.e. reach the point where half the known oil reserves and projected oil yet to be discovered are used up. This peak is likely to occur in 2020 according to Cassandra's, and in year 2040 according to Optimists [9]. With Nuclear energy still failing to address peak demands issues, hydrogen energy still under research and development, and renewable energy not fully mature, fossil fuel technology still remains a must-consider solution. The first scenario of this study tackles energy requirements in a Business As Usual (BAU) Scenario, a Scenario typically adopted by countries usually tending to follow rather than lead.

### **1.2.2. Renewable Energy Sources in Islands**

With increasing interest in renewable energy sources and adoption of these sources in large grids, the next challenge apart to further increase the unit production is to integrate these sources into small energy systems. The perfect nest for such a request is nothing but islands which apart usually being abundant in Renewable energy sources such as wind and sun, also necessitate such energy to avoid costly electricity cables. The second Scenario investigates such a challenge which integrates fossil fuel generated energy together with renewable energy.

### **1.2.3. The Hydrogen Era**

The concept of a hydrogen economy originated in the early 1970s. The first World Hydrogen Conference in 1976 identified hydrogen as a clean energy carrier for the future. The Australian chemist John Bockris first used the phrase "hydrogen economy" in the early 1970s [10]. In the hydrogen economy, a "substantial fraction of energy is delivered by hydrogen made from sources of energy that have no net emissions of greenhouse gases"[11]. In June 2003, a group of top-level stakeholders in the field of hydrogen and fuel cell technologies – the so-called "high level group" presented their vision report "Hydrogen and fuel cells – a vision of our future" [12]. From then on,

more elaborated research has been going including changes in policies and research which led to a better understanding of such scenario.

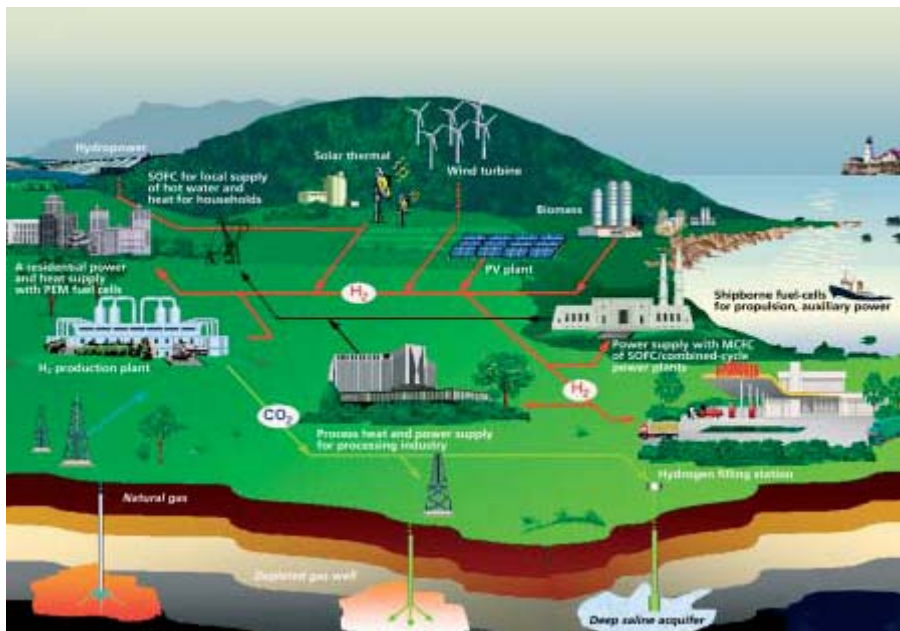

**Figure 1: An integrated energy system including hydrogen as envisaged by [13].**

The hydrogen epoch is a scenario in which there is an attempt and eventually success “to change the current energy system to one which attempts to combine the cleanliness of hydrogen as an energy carrier with the efficiency of fuel cells (FC) as devices to transform energy into electricity and heat.” [14]. This energy carrier, however, must be obtained from other energy sources, in processes that, at least in the long term, avoid or minimize CO<sub>2</sub> emissions.

The third scenario of this study deals with hydrogen for cars from Renewable energy sources. Experience and new polices led to some achievements in this field possibly leading to achieve such targets. Automakers investing more resources into the R&D of such technology mainly in achieving a reduction of the weight and volume of PEM fuel cells for use in cars. More durable membranes to achieve the required 5000 hour life time needed for commercial vehicles and above all the reducing the over all cost of hydrogen powered cars which once being mass produced this should be solved [15]. All these challenges, together with others are being tackled, and promising results are envisaged in the coming decade. Studies and publications are investigating the potential of renewable generated. Such a wide interest is especially applicable in stand alone power supply systems (SAPS) [16], [17], [14]. The challenges in placing this technology as a commercial one is surely fundamental and the costs have to be analysed on a case by case [18]. In parallel, responsible authorities are preparing infrastructure and policies in order to accommodate the introduction of

such technology. For example, the U.S. department of energy is developing safety codes and standards for hydrogen fuel whilst that the E.U. has set itself the objective of a 10% substitution of traditional fuels in the road transport sector (gasoline and conventional diesel) by alternative fuels before the year 2020. Three alternative solutions are seen as promising: biofuels, natural gas and hydrogen [19].

### **1.3. Hypothesis**

Involving high initial capital investment and usually being considered as energy resources with a negligible capacity value i.e. one cannot depend entirely on renewable resources to meet the load demand, renewable energy has not been as successful as intended, despite widespread consumer concern about the environment. This is also applicable to systems including hydrogen blocks. Such a study analysing the success of a scenario was performed in [20].

This study proposes a hypothesis that the introduction of Renewable Energy sources is a practical (both economic and functional) issue for the island of Malta considering climate change concerns. The hypothesis that the possibility of a method of increasing the renewables penetration into island energy system exists is then further investigated by changing the application principle from that of using Renewable generated power directly into the grid to converting renewable energy into hydrogen and utilising it for the transport sector. Finally the relevant prices for such scenarios are investigated. Such hypothesis also gives ideas of the quantities of units needed for a given percentage of either renewable energy or fuel for transport. The practicality of each scenario is also discussed and analysed. The application of Kyoto flexible mechanisms namely Clean Development Mechanism (CDM) is investigated applied to allocated Carbon limit emissions.

### **1.4. What are the achieved results**

The results achieved from this study aim to provide quantitative and qualitative information about the outcome of three possible scenarios in Malta. Apart from analysing some quoted figures, the study suggests possible solutions, figures and prices in order to achieve specific targets set either by International standards or the country itself. Limitations present in the Island itself are also considered. Some results suggest another way of tackling issues whilst others move hand in hand with ones already suggested. In some cases the obtained results defeat common public ideas.



## **2. Methodology**

### **2.1. Data Collection and Analysis**

When data collection is necessary, usually there are different methods that one can use [21]. Typically these consist of:

- Method 1: Surveys and questionnaires

Such a method is usually used to collect data related to participants, families, staff and administrators, teachers, community members, and other stakeholders. Data collected often include demographic information, satisfaction levels, and opinions of the program. The advantages of such a method is usually time consumption and cost which is usually the least out of all other methods however it usually does not provide a clear picture of the real situation.

- Method 2: Interviews and Focus Groups

This method is similar to Method 1, however, it usually targets a specific sample. Thus, it provides a richer data that can paint a broad picture. It is however more time consuming and costly since it is usually more difficult to obtain the requested data.

- Method 3: Observations

Observations are a generally unobtrusive method for gathering information about how the program or initiative operates. They are usually conducted by external evaluators or researchers and are often used to verify and supplement information gathered through other methods. Usually applied as a method for assessing quality of standards or service. This provides a highly detailed information from an external perspective on what actually occurs, avoiding the doubt that the evaluators may be biased towards the end result. However, this method is very time consuming and costly.

- Method 4: Tests and Assessments

Tests and assessments are developed or used specifically for the program evaluation to quantify characteristics of the program, participants, or outcomes. These may be standardized or created by program evaluators for the specific program usually collecting information such as academic achievement, mental and physical health, social skills etc. Thus, such procedure is not based on perceptions or opinions and is usually considered more valid whenever possible.

- Method 5: Document Reviews

Document reviews analyze existing program records and other documents not gathered or developed specifically for the evaluation. Such examples include staff records and annual reports. They are particularly useful for documenting implementation. The pros of such method is that the records is usually accurate, tailored information, thus saving on time and costs. However some records may not be available, applicable or complete for some indicators.

- Method 6: Secondary Sources and data reviews

Secondary sources and data reviews use existing documents or data that were originally collected for purposes other than the program evaluation or documentation, but which are useful for the evaluation. Such examples include court records, and community demographic data.

The above methods are usually combined in order to obtain the best data collection structure for the purpose of the study. Using multiple methods to assess the same outcomes (e.g. using surveys and document review to assess program management) provides a richer, more detailed picture. Of particular importance is also the source of data. When it comes to international data, usually some of this data is manipulated or misinterpreted by media for political reasons.

In climate change and related studies, the availability of data is of utmost importance. Only by such means can international authorities monitor the ongoing progress and evaluate future trend and effects. Obtaining the necessary data is not an easy task either it be on a national level or international level. The NAP communication structure is one of the structures intended to gather such data. The method of data collection is usually a function of the authority / persons gathering it. At national level, for example, methods 1 to 4 are usually adopted. Reporting principles such as Relevance, Completeness, Consistency, Transparency and Accuracy are fundamental at this level. However, in studies such as the one presented here, methods 5 and 6 are the most applicable since these make use of already published accurate data. It has however to be stressed out that data published from competent authorities should be as much as possible analysed in order to ensure the correctness of the results. Though the data is usually available, some extrapolation is usually always needed in order to obtain the exact required data. In this thesis, the following approach was taken.

- Data was evaluated at the earliest stage possible if available. E.g. Load growth was directly calculated using hourly data and not quoting already estimated load growth.

- Typical emissions according to technology were applied to raw data. E.g. emissions from transport were obtained using typical emission figures for diesel and petrol engines and then applying it to the travelled kilometres.
- Typical trends were assumed when no idea of future figures. E.g. CDM targets for year 2025 are not yet clear however, analysing applied philosophy and using available ones, these could be estimated.

By such means, the calculated figures could be benchmarked against already existing ones whilst that the origins of the actual data analysed from earlier stages.

## **2.2. Predicting the growth rate and future load demand.**

“Predicting the future of electricity and load forecasting is not a science-it’s an art.”, Core. A system underrating could lead to a shortage of capacity, which would result in poor quality of service including load shut off. On the other hand, a system overrating of a plant that may not be needed for several years, leads to revenue loss. Moreover, in view of the ongoing changes with associated unbundling of electricity supply services, tariff reforms and rising role of the private sector, a realistic assessment of demand assumes ever-greater importance. The forecast further drives various plans and decisions on investment, construction and refurbishment to meet peak loads and the patterns of demand in different seasons, months, and times of day.

To deal with load growth prediction, many forecasting techniques have been developed, ranging from very simple extrapolation methods to more complex time series techniques, extensive accounting frameworks and optimization methods, or even hybrid models that use a combination of these. Some of these include the Trend method, End use method, the Econometric Approach, Time series method, and other hybrid variants of the mentioned ones.

## **2.3. Technology overview and status**

### **2.3.1. Wind Energy**

Wind power, or wind energy, is a renewable resource; it is from the sun. The intensity of solar radiation differs across the globe. Some areas receive intense amounts of sunlight, while others receive much less. The regions around equator, at 0° latitude are heated more by the sun than the rest of the globe. The result is a temperature gradient; a gradient which is mediated by the flow of air to and from areas of dissimilar temperatures and pressure systems in our atmosphere. Hot air is

lighter than cold air and will rise into the sky until it reaches approximately 10 km altitude and will spread to the North and the South. If the globe did not rotate, the air would simply arrive at the North Pole and the South Pole, sink down, and return to the equator. However due to the earth's rotation and irregularities on the earth's surface, uneven heating of the earth's atmosphere occur causing flow patterns which are also shaped by the terrain, water bodies, and vegetation.

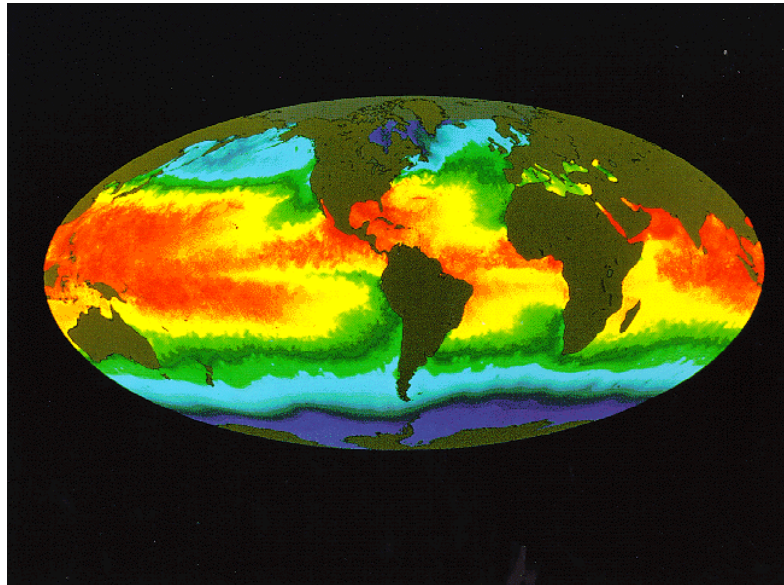

**Figure 2: Temperature variations across the globe by NASA - July 1984 [22].**

All renewable energy (excluding tidal and geothermal power), and even the energy in fossil fuels, ultimately comes from the sun. The sun radiates 174,423,000,000,000 kilowatt hours of energy to the earth per hour. In other words, the earth receives  $1.74 \cdot 10^{17}$  watts of power per hour. In principle, assuming global utilisation, up to 3% of this energy could be extracted from the atmosphere by wind turbines. If this 3% of total kinetic energy of the atmosphere were actually extracted, this would cause an increase in surface friction over the land and water masses of less than 10%. It is thus evident that large scale wind energy utilisation would hardly result in any disturbance of the natural global weather conditions. However this amount of energy would still result in great amount of energy to reduce our dependence on fossil fuels and cater for our on-growing energy needs.

### **2.3.1.1. Betz limit**

The mechanism behind extracting energy from wind is based on reducing the wind velocity by means of aerofoil surface resistance. This reduction in energy is then transformed to torque with which the shaft generally coupled to an electric generator translates into electrical energy or other sort of useful energy. The physical conditions governing free wheeling wind turbines were first described by Betz (1923) and Glanert (1926). Betz' law states that one can only convert less than 16/27 (or 59%) of the kinetic energy in the wind to mechanical energy using a wind turbine. This limit is further reduced due to losses occurring during the energy conversion (kinetic to kinetics) owing to the finite number of blades, vorticity and friction.

### **2.3.1.2. Uniformity of Available Energy supply**

At a stage of understanding the concept of wind energy, one has to be aware of the intermittence and effects of wind energy. The duration of fluctuations varies in time and location. In order to partly compensate for this, different approaches were taken.

Stall and pitch regulation methods have been employed in order to adjust for varying wind speeds. In the former, the blades are rigidly fixed to the turbine hub and cannot be turned around their longitudinal axis during operation. Adversely, in the latter the blades are mounted on the rotor hub with turntable bearings. They can be turned around their longitudinal axis during operation. Both methods aim to reducing the blade lift to yield precisely the maximum power output specified. Further to these methods, power electronics are coupled to the system in order to provide as smooth electrical output as possible. To further cancel the wind power fluctuations, statistical wind data led to the conclusion that intermeshed operation of several wind power plants spaced sufficiently apart in different places cancels the uneven distribution of wind energy. Further more, the combination of a power plant to wind farms will further on stabilise the system. The effect of wind power fluctuations was further elaborated in [23].

### **2.3.1.3. Current Status of wind technology.**

Different policy frameworks gave a boost to the utilisation of wind energy. Over the period 1998-2003, the global wind power capacity has expanded at an average cumulative rate of 32 %. At the end of 2006, worldwide capacity of wind-powered generators was 73.9 Gigawatts [24]. The added capacity equals a growth rate of 25 % in year 2006 after 24 % in 2005 [25]. These are positive figures which enhance research and development in this field. Bigger and better optimised wind turbines are being designed and power electronics converter advancements help in the integration of

these systems into national and international grids. Mass production of this technology together with technical improvements, lower capital and development costs for turbines lowered the average kWh price costs for electricity generated from wind making this technology feasible in combination with conventional power stations.



**Figure 3: The promising offshore wind farm idea [26].**

To date (2007) the biggest wind power turbine reaches the 5 MW limit having a rotor blade of more than 100 metres. Different patented technology exists which is beyond of this study and is not mentioned herewith. However, all technologies aim to obtain the best output at the most feasible cost. At the moment, it is important to mention that there is a growing concern, research and development in obtaining wind power from offshore locations. This is so since the wind at sea is generally less turbulent than on land. Wind turbines located at sea may therefore be expected to have a longer lifetime and better output than land based turbines. Apart all this, such technology may be useful for islands lacking space for wind turbines installation.

## **2.3.2. Solar**

### **2.3.2.1. Efficiency**

With ever increasing efficiencies (refer to 2.3.2.4) yet, the overall system efficiency leaves more to be desired. For an island like Malta with limited space available, higher efficiency systems will surely help in order to penetrate the technology faster and easier.

### **2.3.2.2. Cost**

Currently, the cost of 1kWh of energy from PV in the EU is between a quarter and a half euro range. The prices vary since it is obviously cheaper to produce PV electricity in southern Europe than in the north. For example in 2006, the production of solar electricity from a typical 4 kilowatt (kW) rooftop system in Germany cost 30 cents per kWh, in Spain it was 19 cents, and in California it was 22 cents [27]. Typical production costs including system installation were approximately \$3,600 per kW last year, with particularly efficient companies producing for costs of less than \$3,000 per kW. By 2010, this price is expected to plummet to \$2,500. [27]. In evaluating feasibility of PV, prices ranging circa 5000Euros per kW are usually quoted. For example [28] calculates that a 1.2 kWp system costing Lm2500 (5,750 Euros) and occupying a flat roof area of about 7 m<sup>2</sup>. This leads to an approximate price of 4,791 Euros per kWp.

### **2.3.2.3. Risk**

The reduced risk in investing in solar [29] is attracting greater numbers of businesses, public agencies and non-profitable organisations to use power from the sun. However, this risk has to be further enforced by government providing stable incentives, encouraging feed in- tariffs and reduced taxes. Further more manufacturers are providing extended warranty periods which surely helps in PV interest. Unlike purchasing electricity from the utility companies, PV-sourced electricity is not dependent on the volatile hydrocarbon spot market which is constantly affected by the price of foreign oil and worldwide instable politics. The almost zero variable cost and an increasing value as oil price rise both contribute to a nearly risk less investment.

### **2.3.2.4. Current status of solar energy**

The phenomena of converting light into electricity was first observed in 1839 by the French scientist Becquerel. From then on, research and development continued to provide us with photovoltaic technology used in a lot of applications from terrestrial to satellite applications and so on. With the earth demand for the reduction of GHG gasses, PV is gaining more and more momentum yet, it still has to exploit its vast potential.

There are diversified solar cell materials, which vary in conversion efficiency and cost. The performance depends on the chosen type, orientation and the operation temperature. Individual cells are hooked up together in order to increase the voltage or the current. Photovoltaic power can be produced in many ways, with widely varying efficiency and costs.

The technology can be divided into two basic groupings: discrete cell technology and integrated thin film technology.

- Discrete Cell Technology
  - Single-crystal technology: 200 microns technology with typical 15% efficiency and lab tests leading to up to 24% efficiency.
  - Multicrystalline Silicon: less expensive to manufacture and less efficient than single-crystal silicon cells. Typical efficiency of 14% and research cells approaching 18%.
  - Dendritic web: Technology usually used in space power systems with research cells reaching between 25 to 30% of efficiency.
- Integrated thin film Technology
  - Copper Indium Diselenide (CuInSe<sub>2</sub>), or CIS: A polycrystalline material, mostly used in consumer products for solar watches and calculators. Amorphous Silicon (a-Si) technology is also used in building-integrated systems, replacing tinted glass with semi-transparent modules. Typical efficiency varying from 11 to 18% with the primary issue remaining the low efficiency and associated greater requirement for space and higher array installed cost and weight.
  - Cadmium Telluride (CdTe): A polycrystalline material, deposited by electro deposition, spraying, and high-rate evaporation. Experimental devices approaching 16-percent efficiency and production modules at approximately 7%.

### **2.3.3. Hydrogen**

#### **2.3.3.1. Risk**

The impacts and risks of investing in a hydrogen scenario depend on what the future holds for the energy supply, energy prices, their impact on the economy, and environmental concerns such as climate change. Technical uncertainties translate into investment risk to investors and stakeholders however these will be overcome once a market structure is present. Though one can not deny that there are risks in making too large an investment too quickly, the risks from not making investments in hydrogen are greater. Such risks incurred due to lack of investment in hydrogen include risks to the environment in terms of climate change caused by fossil fuel scenario. Additional risks include



dependence on a single source of energy for transportation and risks from potentially reduced reliability of the electricity supply.

Firm and consumer perceptions about the risk associated with some long-lived capital investments may significantly affect the rate at which hydrogen is introduced, and the selection of one technology pathway over another. The optimistic sales pitch about "clean energy emitting only water vapour" and the enthusiasm of a hydrogen era only seem likely to approach fruition if the regulatory, incentives and permitting schemes that are developed are both strong enough to inspire public confidence. These should facilitate safe, cost-effective development in a marketplace which has yet to develop and which could evolve in a number of different and unpredictable ways.

### **2.3.3.2. Current status of hydrogen energy**

Whilst that a hydrogen scenario is composed of many building blocks, the basic elements of such a system will always be the Fuel cell, the electrolyser and the hydrogen storage methods. The following aims to provide an overview of where such technology is.

- Fuel Cell

The electrolyte (the medium which provides the ion transport mechanism between the positive and negative electrodes of a cell) employed by the fuel cell classifies the type of fuel cell. This determines the kind of chemical reactions that take place in the cell, the kind of catalysts (the substance that speeds up a reaction without undergoing any permanent chemical change ) required, the temperature range in which the cell operates, the fuel required, and other factors. These characteristics, in turn, affect the applications for which these cells are most suitable. There are several types of fuel cells currently under development, each with its own advantages, limitations, and potential applications. Some of the most interesting ones are compared in Table 1

**Table 1: Types of available fuel cells [30]**

	MCFC	PAFC	PEMFC	SOFC
<b>Electrolyte</b>	Molten carbonate salt	Liquid phosphoric acid	Ion exchange membrane	Solid metal oxide
<b>Operating Temperature</b>	1100–1830°F (600–1000°C)	300–390°F (150–200°C)	140–212°F (60–100°C)	1100–1830°F (600–1000°C)
<b>Reforming</b>	External/Internal	External	External	External/Internal
<b>Oxidant</b>	CO <sub>2</sub> /O <sub>2</sub> /Air	O <sub>2</sub> /Air	O <sub>2</sub> /Air	O <sub>2</sub> /Air
<b>Efficiency</b> (without cogeneration)	45-60%	35-50%	35-50%	45-60%
<b>Maximum Efficiency</b> (with cogeneration)	85%	80%	60%	85%
<b>Maximum Power Output Range</b> (size)	2 MW	1 MW	250 kW	220 kW
<b>Waste Heat Uses</b>	Excess heat can produce high-pressure steam	Space heating or water heating	Space heating or water heating	Excess heat can be used to heat water or produce steam

- Electrolyser

The ever increasing pressure for the reduction of carbon dioxide led to further interest in the production of hydrogen in a clean way. Hydrogen production processes in year 2002 was envisaged by [31]. What was then seen as future is now seen as present or else testing period. The idea of producing hydrogen for a hydrogen scenario using renewables which most of the time produce some excess energy is a very interesting process.

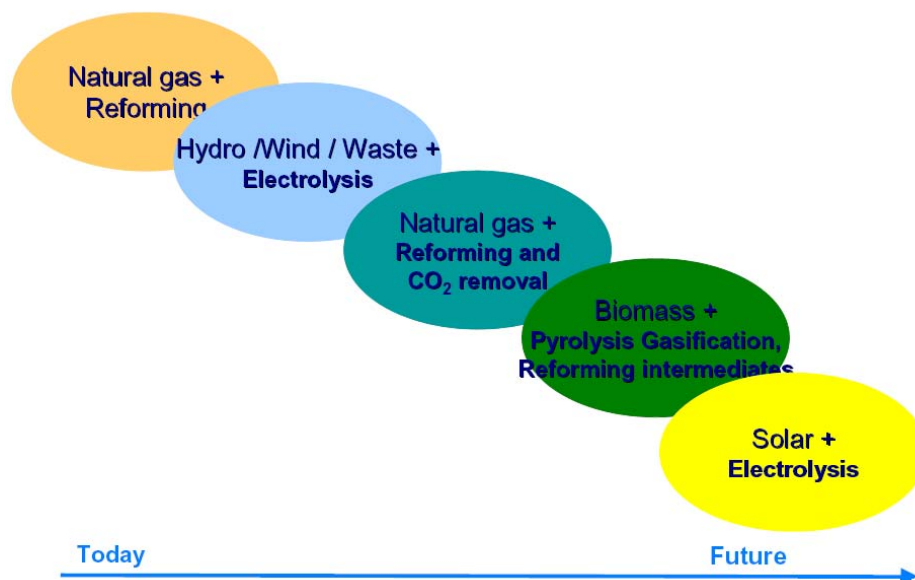
**Figure 4: Hydrogen production processes as envisaged by [31] in year 2002**

The core of an electrolysis unit is an electrochemical cell, which is filled with pure water and has two electrodes connected with an external power supply. At a certain voltage, which is called

critical voltage, between both electrodes, the electrodes start to produce hydrogen gas at the negatively biased electrode and oxygen gas at the positively biased electrode. The amount of gases produced per unit time is directly related to the current that passes through the electrochemical cell.

Electrolysis plants with normal or slightly elevated pressure usually operate at electrolyte temperature of 70-90°C, cell voltage of 1.85-2.05 V and consume 4-5 kWh/m<sup>3</sup> of hydrogen, which is obtained at a purity of 99.8% and more. Pressure electrolysis units run at 6-200 bar and there is no significant influence on the power consumption. Because of its high energy consumption and also of the quite substantial investment, water electrolysis is currently used for only 4% of world hydrogen production. [Varkaraki, 2003]

**Table 2: Electrolysis technologies compared [32]**

Efficiency of H <sub>2</sub> production from electrolysis (incl. auxiliaries, no compression)					
Technology	Alkaline large-scale	Alkaline high-pressure	Advanced Alkaline	PEM	SOFC
Status	Commercial	Commercial	Precommercial	Precommercial	Prototype
T (°C)	70-90	70-90	80-140	80-150	900-1000
P (bar)	atm. to 25	up to 690	up to 120	up to 400	up to 30
kWh/kgH <sub>2</sub>	48-60	56-60	42-48	40-60	28-39

Alkaline electrolyzers with potassium hydroxide (KOH) electrolyte are commercially available. Efficiency is a key parameter for electrolysis, as costs are largely determined by electricity costs. Best-practice efficiency could be higher than 85% (GJH<sub>2</sub>/GJ<sub>el</sub>), but commercial devices achieve between 55% and 75%. New advanced electrolyzers may approach the upper limit. At high temperatures, heat consumption increases while electricity needs decrease. High-temperature electrolysis (800°C-1,000°C) may therefore offer higher efficiency, in particular using residual heat. Also, high-pressure electrolysis can make H<sub>2</sub> pressurisation unnecessary and improve efficiency. New electrolyser concepts are based on fuel cells working in reverse mode. Small-scale polymer electrolyte membrane FC (PEMFC) electrolyzers (60°C-80°C, 15 bar, 50% efficiency) are commercially available. Solid oxide FC (SOFC) electrolyzers functioning at 700°C-1,000°C need more research. Current electrolysis costs are typically above \$30/GJH<sub>2</sub>, but could drop to below \$20/GJ (including pressurisation) over coming decades, assuming electricity at \$35/MWh and 80% process efficiency. Use of off-peak electricity and large-scale plants may reduce costs, although the cost of CCS (carbon capture and storage) is expected to increase the cost of electricity. [32]

The following gives an overview of the most important electrolysis processes:

- Alkaline electrolysis

This technology offers the advantages of materials such as potassium hydroxide (KOH) which are cheaper and less susceptible to corrosion compared to those required to handle acids. Alkaline electrolyzers use an aqueous KOH solution (caustic) as an electrolyte that usually circulates through the electrolytic cells. Alkaline electrolyzers are suited for stationary applications and are available at operating pressures up to 25 bar [33]. Alkaline electrolysis is a mature technology, with a significant operating record in industrial applications. Commercial electrolyzers usually consist of a number of electrolytic cells arranged in a cell stack. The major R&D challenge for the future is to design and manufacture electrolyser equipment at lower costs with higher energy efficiency and larger turn-down ratios.

➤ Proton exchange membrane electrolysis

The proton exchange membrane water electrolysis is based on the use of a polymeric proton exchange membrane as the solid electrolyte ('polymer electrolyte membrane'). The inherent advantages of polymer electrolyte technology over the alkaline one are:

- (i) greater safety and reliability are expected since no caustic electrolyte is circulated in the cell stack.
- (ii) previous tests made on bare membranes demonstrated that some materials could sustain high differential pressure without damage and were efficient in preventing gas mixing.
- (iii) the possibility of operating cells up to several amps per square centimetre with typical thickness of a few millimetres [Millet, 1996].

However, ultra pure water (1  $\mu$ Siemens compared to 5  $\mu$ Siemens for an alkaline unit) has to be fed to the anode structure of the electrolysis cell. A major problem of electrolyzers of this type is the limited lifetime of the electrolysis cells. Today PEM electrolyzers are developed commercially in the range 0.5 to 10 Nm<sup>3</sup>H<sub>2</sub>/hr, producing hydrogen of very high purity, at prices comparable to that of alkaline units. Versions of such electrolyzers suitable for coupling with stochastic renewable energy sources are available but currently have limited warranty.

➤ Steam electrolysis

Steam electrolysis is a technology that has the potential to reach higher total energy efficiency compared to alkaline and proton exchange membrane electrolysis. It is more advantageous to electrolyse water at high temperature (800-1000°C) because the energy is supplied in mixed form of

electricity and heat and heat is much cheaper than electrical energy apart that it is sometimes not utilised in power generation utilities. Despite this high efficiency with respect to electricity, the high temperature system still produces hydrogen at about four times the cost of hydrogen produced through steam reforming of natural gas.

A new approach to reduce the electricity consumption in electrolyzers was achieved by using natural gas in order to reduce the chemical potential difference across the electrolyser cell. The concept is called Natural-Gas-Assisted-Steam Electrolysis (NGASE). In this new technology, the air in the anode side is replaced with natural gas in order to lower the open circuit voltage and thereby the electricity consumption. The reducing character of natural gas helps to lower the chemical potential difference between the two sides of the electrolyser. The scale-up to large water electrolysis units using this technology is currently under development.

➤ Solid Oxide Electrolysis

This could be a sub-category of steam electrolysis. The operation of a solid-oxide electrolyser depends on a solid ceramic electrolyte (zirconia/ceria), which at temperatures of 800-1000°C transfers oxygen ions ( $O^{2-}$ ). The solid oxide electrolyser requires a source of high-temperature heat. By operating at elevated temperatures, the heat input meets some of the energetic requirement for electrolysis and so less electricity is required per  $m^3$  of  $H_2$  generated, compared with the other electrolyser technologies. To date, prototype solid-oxide electrolyser units have not achieved useful operational lives and substantial engineering problems exist with respect to thermal cycling and gas sealing. Accordingly, it is premature to make comparisons with alkaline and PEM electrolyzers [Newborough, 2004].

The previously mentioned steam electrolysis and solid oxide electrolysis are both suitable for operation along a high temperature nuclear plant, that would provide the electricity and high temperature heat aiming for the case of large scale centralised production of hydrogen. For smaller distributed generation applications, heat could be supplied by a solar concentrator and electricity by wind turbines or photovoltaic.

• Storage

Hydrogen has a high energy-per-weight but it has a low energy-per-volume. A gram of hydrogen gas occupies about 11 litres (2.9 gallons) of space at atmospheric pressure, so for convenience the gas must be intensely pressurized to several hundred atmospheres and stored in a pressure vessel. The main storage techniques are presented in Figure 5 whose basic idea is to store hydrogen either

by compressing it to different pressures or else storing the hydrogen in hydride form i.e. using an alloy that can absorb and hold large amounts of hydrogen by bonding with hydrogen. On board, H<sub>2</sub> storage presents R&D challenges. The volumetric capacity, high pressure and cost must be feasible in order for the technology to catch up. The energy needed in order to store hydrogen as gas and liquid represents about 12% and 35% of the H<sub>2</sub> energy content respectively. The target is to store 4-5kg of H<sub>2</sub> (sufficient for a drive range of 400-500km) while minimising volume, weight, storage energy, cost, and refuelling time, and providing prompt H<sub>2</sub> release on demand [32].

Storage method	$\rho_m$ [mass %]	$\rho_v$ [kg H <sub>2</sub> m <sup>-3</sup> ]	T [°C]	p [bar]	Phenomena and remarks
High pressure gas cylinders	13	<40	RT	800	Compressed gas (molecular H <sub>2</sub> ) in light weight composite cylinders (tensile strength of the material is 2000 MPa)
Liquid hydrogen in cryogenic tanks	size dependent	70.8	-252	1	Liquid hydrogen (molecular H <sub>2</sub> ), continuous loss of a few % per day of hydrogen at RT
Adsorbed hydrogen	≈ 2	20	-80	100	Physisorption (molecular H <sub>2</sub> ) on materials e.g. carbon with a very large specific surface area, fully reversible
Absorbed on interstitial sites in a host metal	≈ 2	150	RT	1	Hydrogen (atomic H) intercalation in host metals, metallic hydrides working at RT are fully reversible
Complex compounds	<18	150	>100	1	Complex compounds ([AlH <sub>4</sub> ] <sup>-</sup> or [BH <sub>4</sub> ] <sup>-</sup> ), desorption at elevated temperature, adsorption at high pressures
Metals and complexes together with water	<40	> 150	RT	1	Chemical oxidation of metals with water and liberation of hydrogen, not directly reversible?

Figure 5: The six basic hydrogen storage methods and phenomena [34]

As regarding large scale nation wide storage of hydrogen, unfortunately, there are many problems that have prevented and continue to prevent hydrogen from being used on a large scale. The increasing concentration and R&D for on-board storage is keeping large scale storage under incubation process yet providing a lot of experience for near future development.

### 2.3.3.3. Potential and barriers of the hydrogen scenario.

With the ever increasing fuel cost and advances in R&D in the hydrogen field, hydrogen is likely to catch up within 20 years. Transition to a hydrogen economy has to be enforced however using targets, regulations, standards, planning guidance, incentives, fiscal measures, grants and public procurement. H<sub>2</sub> production costs should be reduced by a factor of 3 to 10 (depending on technologies and processes) and fuel cell cost by a factor of 10 or more. At the same time, emission reduction incentives of \$25-\$50/tCO<sub>2</sub> (depending on fossil fuel price) would help to make H<sub>2</sub>, fuel cells and other clean energy options more competitive economically. Under these assumptions, emissions growth over the coming decades could be reduced in proportions that would bring annual emissions in 2050 down to half those projected in a business-as-usual scenario. In addition to costs

and competition from other technologies, barriers to H<sub>2</sub> market uptake include the need for dedicated infrastructure. However, no single fuel or technology is likely to meet the expected fast-growing demand for clean transport fuels [32].

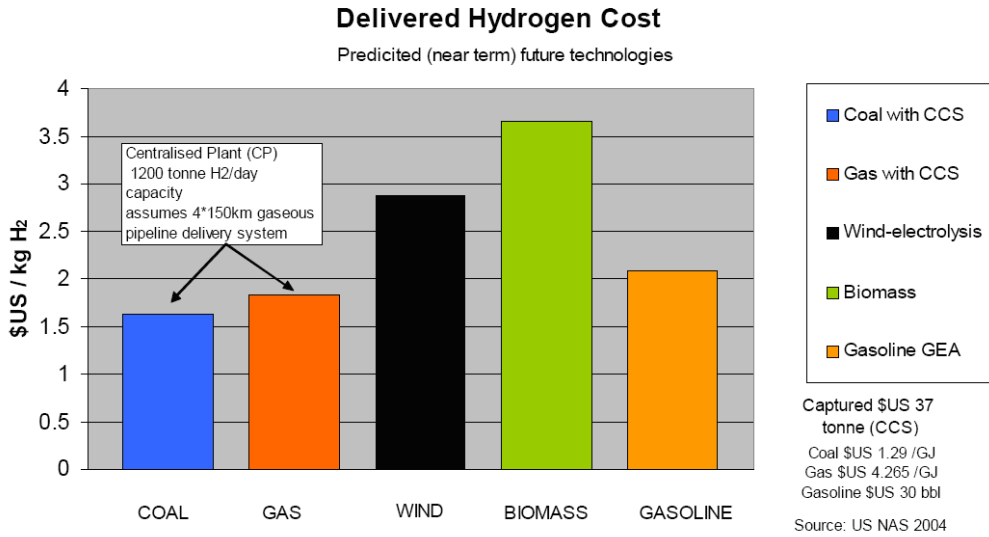

Figure 6: Typical hydrogen cost produced from different technologies [35]

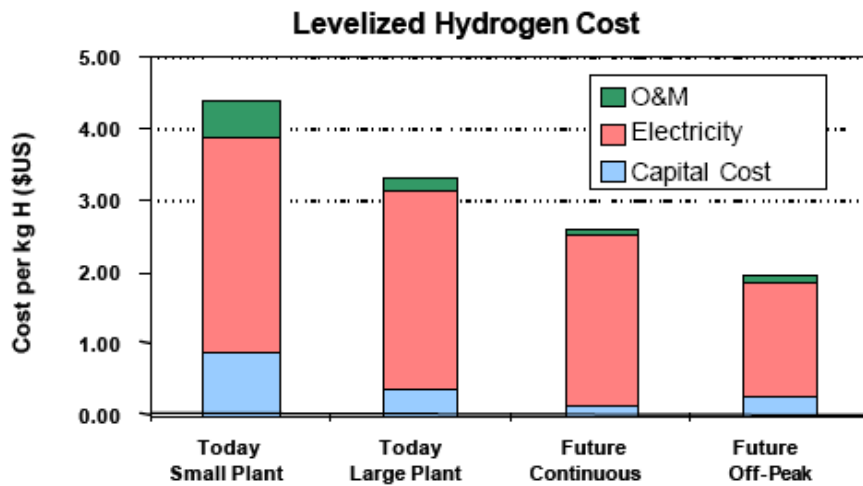

Figure 7: Future potential cost of electrolytic hydrogen [36].

Public awareness of the benefits of using hydrogen and provision of information on hydrogen safety are likely to be key to acceptance of the technology. Demonstration projects involving hydrogen use in buses and public buildings have been well accepted elsewhere in the world and are considered to be one of the best ways to introduce the technology to a wide range of people.

## **2.4. Methodology and Simulation model**

A general methodology for the assessment of alternatives for the introduction of renewable energy and hydrogen based energy systems in islands is imperative in order to map the islands' necessities. This arises from the fact that the ever increasing technologies for both renewables utilisation and storage offer a wide range of possibilities that have to be logically analysed in order to come out with the best possible solution. The methodology is general and can be applied to systems other than islands, however, islands' specificities have to be carefully considered especially when characterising the needs and resources and assessing the feasibility of the system, as classifying the different options will be based on islands conditionings.

### **2.4.1. RenewIslands methodology**

A lot of simulation tools have lately been developed, however not all are suitable for stand alone systems such as Islands. For example EnergyPlan [36] is well suited for decentralised power generation, and it also integrates heat demand into the model, enabling the optimisation of combined heat and power generation. It also integrates other intermittent resources and optimises different strategies to treat the excess power. However, it does not treat hydro resource, water demand, hydrogen demand, reversible hydro, hydrogen storage, batteries and other specifics of the isolated power system. Homer software approaches closer to meeting the islands demands however it still lacks reversible hydro and water demand treatments, which is the cheapest way to store energy in those islands where the potential is present.

RenewIslands methodology [37] was developed in order to enable assessment of technical feasibility of various options for integrated energy and resource planning of islands. A comparison between models is further elaborated in [38]. The RenewIslands methodology is based on a four step approach that has to be applied to an island:

1. Mapping the needs
2. Mapping the resources
3. Devising scenarios with technologies that can use available resources to cover needs
4. Modelling the scenarios

The needs are commodities that the local community demands, not only energy (electricity, heat, cold, fuel for transport, etc.), but also all other types of commodities (or utilities in the old



command jargon), like water, waste treatment, wastewater treatment, etc. that are depending on energy supply.

The resources are locally available ones, like wind, sun, geothermal energy, ocean energy, hydro potential, water resources, but also imported ones like grid electricity, piped or shipped natural gas, oil derivatives or oil, the potential to dump waste and wastewater, etc.

The technologies can be commercial energy conversion technologies, like thermal, hydro and wind electricity generation or solar thermal water heating, commercial water, waste and wastewater treatment technologies including desalination, or emerging technologies, like geothermal energy usage, solar electricity conversion systems, or technologies in development, like fuel cells, wave energy, etc.

The scenarios should try to satisfy one or several needs, by using available resources, and satisfying preset criteria. Due to global warming and falling reserves, and sometimes security of supply problems, fossil fuels should generally be used as the option of last resort in setting scenarios, even though they will often provide the most economically viable solution with the current price levels, and advantage should be given to locally available renewable resources.

By use of the methodology, islands have been approached and implementation of methodology to each island gave bigger difference in the first two steps, which were more due to local conditions while the third and fourth step brings more similar results. It was that electricity and hydrogen are good solutions for energy carriers or energy vectors. The authors also find that integration of electricity and hydrogen production is good solution for increasing the overall system efficiency.

#### **2.4.1.1. Mapping the needs**

The level of need for each commodity has to be defined locally, but generally, in order to have sustainable development, water and electricity will always be highly demanded, no matter what is the demand per person, or total actual demand, unless it is a community of only few households, that can then use individual solutions. Heat demand will be deemed high in cold climates, as cold will be deemed high in hot climates. Waste treatment and wastewater treatment will depend on the ability of local environment to absorb the dumped amounts.

**Table 3: General mapping of the needs**

Needs	Level	Geographic Distribution	Code	Level	Distribution
<b>Electricity</b>	Low, Medium or High	Dispersed, Concentrated	Elect	L/M/H	D/C
<b>Water</b>	Low, Medium or High	Dispersed, Concentrated	Water	L/M/H	D/C
<b>Heat</b>	Low, Medium or High	Dispersed, Concentrated	Heat	L/M/H	D/C
<b>Cold</b>	Low, Medium or High	Dispersed, Concentrated	Cold	L/M/H	D/C
<b>Transport fuel</b>	Low, Medium or High	Short, Long Distance	Tran	L/M/H	S/L
<b>Waste Treatment</b>	Low, Medium or High	Dispersed, Concentrated	Waste	L/M/H	D/C
<b>Wastewater treatment</b>	Low, Medium or High	Dispersed, Concentrated	WWT	L/M/H	D/C

#### 2.4.1.2. Mapping the resources

In this step, the maturity of the technology is the main factor that dictates the choice. Whilst that, for example, wave energy conversion is considered as being potentially promising, the maturity of such technology in no way can be compared to that of wind. Similarly, in no way can the price per kWh produced from solar outweigh wind if both resources are comparatively available.

**Table 4: Mapping the island/remote area resources**

Resource	Level	Code			
<b>Local Primary Energy</b>					
Wind	Low, Medium or High	Wind	WindL	WindM	WindH
Solar	Low, Medium or High	Solar	SolarL	SolarM	SolarH
Hydro (height)	Low, Medium or High	Hydro	HydroL	HydroM	HydroH
Biomass	No, Low, Medium or High	Biom	BiomL	BiomM	BiomH
Geothermal	No, Low, Medium or High	Geoth	GeothL	GeothM	GeothH
<b>Energy import Infrastructure</b>					
Grid Connection	None, Weak or Strong	Grid	GridN	GridW	GridS
Natural Gas Pipe Line	No, Yes	NGpl	NGplN		NGplY
LNG terminal	No, Yes	LNGt	LNGtN		LNGtY
Oil derivatives terminal	No, Yes	OilD	OilDN		OilDY
Oil terminal / refinery	No, Yes	OilR	OilRN		OilRY
<b>Water</b>					
Precipitation	Low, Medium or High	H20P	H20PL	H20PM	H20PH
Ground water	Low, Medium or High	H20G	H20GL	H20GM	H20GH

Water Pipeline	No, Yes	Aqua	AquaN		AquaY
Sea Water	No, Yes	H2OS	H2OSN		H2OSY

It is possible to envisage potential energy carriers as a result of area needs and its resources. Generally, it will be electricity , one or two transport fuels, and district heating in very cold regions of the world.

**Table 5: Potential energy carriers (EC)**

<b>Energy Carriers</b>	<b>Condition</b>	<b>Code</b>
Electricity	IF ElectC	ECEI
District Heating	IF HeatHC	ECDH
District Cooling	IF ColdHC	ECDC
Hydrogen	IF Trans	ECH2
Natural Gas	IF (NGpLY OR LNGtY)	ECNG
Biogas	IF (BiomH OR WasteHC OR WWTHC)	ECBG
Petrol / Diesel	IF (OilRY OR OilDY)	ECPD
Ethanol	IF (BiomH OR WasteHC)	ECEt
LPG	IF (OilRY OR OilDY)	ECLPG
Biodiesel	IF (BiomH AND WasteHC)	ECBD

#### **2.4.1.3. Devising scenario with technologies that can use available resources to cover needs**

Generally, local energy sources will be given priority, due to security of supply reasons. Then, cheaper technologies will be given priority. Technologies will have to be assessed from both a local and global environmental point of view. This step is divided in four sub steps:

##### **I. Feasibility of technologies**

Is a function of a specific demand and the availability of particular resource. It depends on the maturity of technology, commercial, on the quality of resources, but also on the matching of demand and resource. The technologies that have to be taken into account are the ones in energy conversion, water supply, waste treatment and wastewater technology treatment. For example, electrical solar energy conversion system (SECS-PV) is feasible if there is a need for electricity and there is medium to high solar resource

Table 6: Potential delivering technologies

Technology	Condition	Code
<b>Electricity conversion system</b>		
Wind energy conversion system	IF (ElectM OR ElectH) AND (WindM OR WindH)	WECS
PV solar electrical conversion system	IF (ElectL OR ElectM) AND (SolarM OR SolarH)	PV
Solar Energy Conversion system	IF (Elect) AND (SolarH)	SECS
Hydro energy conversion system	IF (Elect) AND (HydroM OR HydroH)	HECS
Geothermal energy conversion system	IF (ElectM OR ElectH) AND (GeothH)	GECS
Biomass energy conversion system	IF (ElectM OR ElectH) AND (BiomH)	BECS
Distributed energy generating system	IF (Elect) AND (NGpLY OR LNGtY OR OilRY OR OiDY)	DEGS
Combined cycle gas turbine	IF (ElectH) AND (NGpLY OR LNGtY OR OilRY OR OiDY)	CCGT
Fuel Cell	IF (Elect) AND (H2Fuel)	FC
<b>Heating system</b>		
Solar Collector	IF (Heat) AND (SolarM OR SolarH)	STCo
Geothermal	IF (HeatH) AND (GeothM OR GeothH)	GeTH
Heat Pump	IF (HeatH AND ECEl)	HPHe
Biomass boiler	IF (HeatH) AND (BiomM OR BiomH)	BMBo
Gas Boiler	IF (Heat) AND (NGpLY OR LNGtY OR OilRY OR OiDY OR WasteG OR WWG)	GSSBo
<b>Cooling system</b>		
Solar absorber	IF (Cold) AND (SolarH)	SABs
Heat Pump	IF (ColdH AND ECEl)	HPCo
Gas coolers	IF (ColdH) AND (NGpLY OR LNGtY OR OilRY OR OiDY OR WasG OR WWtG)	GSCo
Electricity coolers	IF (ColdH AND ECEl)	ELCo
<b>Fuel</b>		
Hydrogen	IF (Tran) AND (ECH2)	H2FUEL
Electricity	IF (Tran) AND (ECEl)	EIFuel
Ethanol	IF (Tran) AND (ECeT)	EthanolFue 1
Biodiesel	IF (Tran) AND (ECBD)	BDFuel

Liquefied Petroleum Gas	IF (Tran) AND (ECLPG)	LPGFuel
Natural Gas	IF (Tran) AND (ECNG)	NGFuel
Biogas	IF (Tran) AND (ECBG)	BGFuel
Petrol / Diesel	IF (Tran) AND (ECPD)	PDFuel
<b>Water Supply</b>		
Water collection	IF (Water) AND (H2OPM OR H2OPH)	WaterC
Water wells	IF (Water) AND (H2OGM OR H2OGH)	WaterW
Desalination	IF (Water) AND (H2OSY)	WaterD
<b>Waste</b>		
Incineration	IF (WasteHC)	WasteI
Gasification	IF (WasteHC)	WasteG
<b>Waste water treatment</b>		
Gasification	IF (WWTHC)	WWG

## II. Feasibility of technologies for energy, water, waste, wastewater storage

Since there is no sort of connection to any mainland as yet, Malta has its oil derivatives storage in order to cater for its energy needs. Reversible-hydro potential is not a feasible solution due to low and distant heights above sea level. Since there are no significant altitude levels, the alternative is hydrogen storage. Excess wind can be electrolysed in order to produce Hydrogen. This is then stored and used in times of low wind or high energy demand unless not used for transport. Energy can also be recovered from waste where most of the waste is gathered in one central place. The landfill can be tapped in order to collect gas which can be used for the production of electricity generation.

Table 7: Potential storage technologies

Storage Technology	Condition	Code
<b>Electricity storage system</b>		
Reversible Hydro	IF (WECS AND HECS)	RHECS
Electrolyser + Hydrogen	IF (WECS OR SECS OR PV) AND NOT HECS	ELYH2
Reformer + Hydrogen	IF (ECNG OR ECBG OR ECPD OR ECET OR ECLPG OR ECBD) AND NOT HECS	REFH2
Batteries	IF (SECS OR PV) AND NOT HECS AND NOT ECH2	BAT
<b>Heat Storage</b>		
Heat Storage	IF (HeatH)	HeatS
<b>Cold Bank</b>		
Cold Bank	IF (ColdH)	ColdS
<b>Fuel</b>		
Hydrogen	IF H2Fuel	H2stor
Ethanol	IF EthanolFuel	Ethanolstor
Biodiesel	IF BDFuel	BDstor
LPG	IF LPGFuel	LPGstor
NG	IF NGFuel	NGstor
BG	IF BGFuel	BGstor
Petrol / Diesel	IF PDFuel	PDstor
<b>Water</b>		
Water	IF Water	WaterS
<b>Waste</b>		
Waste fill	IF Waste	WasteF
<b>Wastewater</b>		
Wastewater tanks	IF WWT	WWstor

**III. Feasibility of integration of flows (cogeneration, tri-generation, poly-generation, etc.)**

In order to maximize the output from a system, it is becoming a common practice to integrate resources and commodities. Poly-generation is a terminology used implying that poly or multi outputs are produced. The most common generation technology being the co-generation, in which both electricity and heat being produced and delivered. Similarly waste is commonly integrated as well with heat and electricity due to high heat produced from the digestion of bacteria present in the waste apart from the ethanol production which can be used for electricity production.

**Table 8: Integration of flows**

<b>Integration Technology</b>	<b>Condition</b>	<b>Code</b>
Combined Heat and Power	IF (Elect PROPORTIONAL Heat) AND (DEGS OR CCGT OR FC OR BECS OR SECS OR GECS)	CHP
Combined Heat and Cold	IF (Heat PROPORTIONAL Cold)	CHC
Trigeneration	IF (Heat PROPRTIONAL(Heat + Cold)) AND (DEGS OR CCGT OR FC OR BECS OR SECS OR GECS)	3G-HPC
Combined water and power	IF (HydroM OR HydroH) AND Water	CWP
Combined waste treatment and heat generation	IF (WasteI AND (HeatM OR HeatH))	CWTH
Combined waste treatment and power generation	IF (WasteI AND (ElectM OR ElectH))	CWTP
Combined waste Treatment and heat and power generation	IF (WasteI AND (ElectM OR ElectH) AND Elect PROPORTIONAL Heat)	3G-WTHP
Combined waste Treatment and heat, power AND cold generation	IF (WasteI AND (ElectM OR ElectH) AND Elect PROPORTIONAL (Heat + Cold))	4G-WTHPC
Combined waste treatment and ethanol production	IF (WasteG AND ECeT)	CWTC2H5OH
Combined waste treatment and gas production	IF (WasteG AND ECBG)	CWTGas
Combined wastewater treatment and gas production	IF (WWG AND ECBG)	CWWTGas
Combined Power and	IF (WECS OR PV) AND ECH2	CPH2

Hydrogen Production		
Combined heat, power and hydrogen Production	IF (SECS OR BECS OR GECS) AND ECH2	3G-HPH2
Combined heat, power, cold and hydrogen Production	IF (SECS OR BECS OR GECS) AND ECH2	4G-HPCH2

#### IV. Devising potential scenario

The above is achievable through different factors. Although the three sub branches discussed above are key factors in devising potential scenarios, so are social acceptance, economic viability, environmental viability, space factor and so on which are not being considered in the logical functions. The Energy policy, however, should consider security of supply and lately introduced green house gas emissions and controls which are at the centre of every analyzed scenario.

##### 2.4.1.4. Modelling

In view of the fact that integration of resources into one system is complex and regular with time, it is only possible to check the viability of scenarios by simulating the scenarios using some simulation package. After the technical limitations of scenarios are checked, during which many of the potential ones are dropped, the financial implications should be checked and compared. During this exercise, it is important to anticipate and include the financial burdens likely to be introduced in order to aim for more environmental friendly technologies. A typical example would be the quota trading scheme of green house gas gases, which is likely to influence the profit form a generating system.



### 2.4.2. H<sub>2</sub>RES computer model

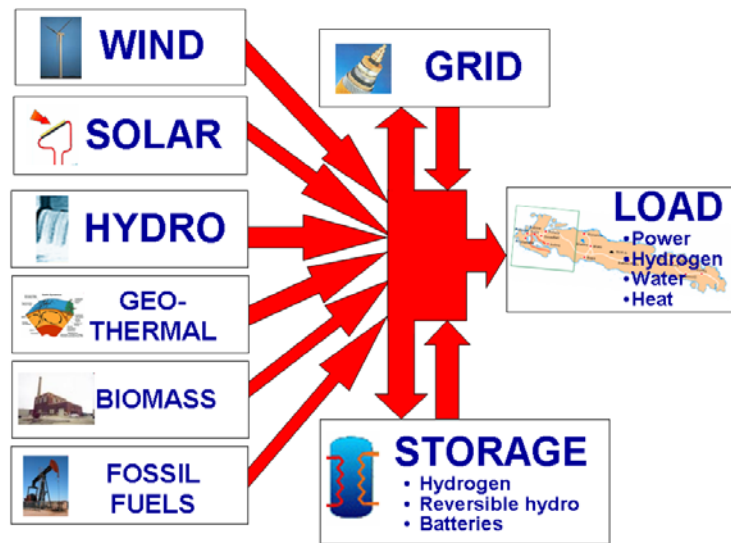

Figure 8: Scheme of H<sub>2</sub>RES 2.5 model.

H<sub>2</sub>RES model is a simulating software developed by the Research Group on Sustainable Development, IST, aimed at investigating the potential and integration of renewable sources and storage into island energy systems based on hourly data on electricity consumption, global solar radiation and mean wind velocity. The model is designed for balancing between hourly time series of water, electricity, heat and hydrogen demand, appropriate storages (hydrogen, reversible hydro, batteries) and supply (wind, solar, hydro, geothermal, biomass, fossil fuels or mainland grid). The hourly balancing is necessary in order to integrate intermittent RES and energy storage for an island power system (Duić et al, 2000). The model has been designed as support for simulation of different scenarios devised by Rewewislands methodology [37] and [39] with specific purpose to increase integration of renewable sources and hydrogen into island energy systems. The main purpose of the model is energy planning of islands and isolated regions which operate as stand-alone systems, but it can also serve as a planning tool for single wind, hydro or solar power producers connected to bigger power systems.

Wind velocity, solar radiation and precipitation data obtained from the nearest meteorological station are used in the H<sub>2</sub>RES model. The wind module uses the wind velocity data at 10 metres height, adjusts them to the wind turbines hub level and, for a given choice of wind turbines, and converts the velocities into the output.

The solar module converts the total radiation on the horizontal surface into the inclined surface, and then into the output.

The hydro module takes into account precipitation data, typically from the nearest meteorological station, and water collection area and evaporation data based on the reservoir free surface to predict the water net inflow into the reservoir.

The biomass module takes into account the feedstock information, the desired mix of feedstock, conversion processes (combustion, gasification and digestion) and desired output production (power, heat or combined heat and power). Biomass module is set to follow the heat load and it generates electricity as by-product. This module has ability to calculate the minimum and maximum potential energy output in order to make optimization of production according to unwanted shutdowns.

The geothermal module functions in continuous, where the installed power generates electricity for the system continuously, except when it is in maintenance. The system primarily uses the electricity produced from geothermal source in detriment of the other power sources, because this is a safe source, not intermittent.

The load module, based on a given criteria for the maximum acceptable renewable electricity in the power system, integrates a part or all of the available renewables output into the system and discards the rest of the renewable output. The excess of renewable electricity is then stored either as hydrogen, pumped water or electricity in batteries, or for some non-time critical use. The energy that is stored can be retrieved later and supplied to the system as electricity or hydrogen for transport purpose. If there is still unsatisfied electricity load it is covered by fossil fuels blocks or by the mainland grid where such connection exists. The model can also optimise the supply of water and hydrogen demand.

The order of sources in supplying of demand could be easily set up according to criteria. In most cases, geothermal energy when available will be considered first, then biomass and then the rest of renewables.

The storage module can either be based on an electrolysing unit, a hydrogen storage unit, and a fuel cell, or a hydro pumping storage, a reversible fuel cell or batteries. The input into the storage system is limited by the chosen power of the electrolyser, the pumps or the charging capacity of the batteries, so the renewable excess power which is superfluous to the storing facility or cannot be taken to the storage system because the storage is full has to be dumped or rejected.

### 2.4.2.1. The Wind module.

The mean hourly wind velocity data is typically obtained from the closest meteorological station. If real data is not available a statistical model can be made as a good approximation. The wind data collected in meteorological stations is not usually measured at the desirable height – the hub height of the wind turbines, so data has to be adjusted from the measuring site height to the specific height of the turbine to be installed. According to RISO, 2003, under the assumption of near-neutral stability, vertical extrapolation of wind speed may be undertaken using the logarithmic wind profile given by the following equation:

Equation 1: 
$$U_z = \left[ \frac{u^*}{\kappa} \right]^\alpha \ln \left[ \frac{z_x}{z_0} \right]^\alpha$$

Where

$U_z$  = wind speed at specified height  $z$        $z$  = height

$u^*$  = friction velocity       $z_0$  = roughness length and

$\kappa$  = von Karman constant

or the power law equation

Equation 2: 
$$U_x = U_0 \left[ \frac{Z_x}{Z_0} \right]^\alpha$$

where  $U_x$  is the wind speed (in meters per second) at height  $Z_x$  (in meters), and  $U_0$  is the known wind speed at a reference height  $Z_0$ . The surface roughness exponent ( $\alpha$ ) is an empirically derived coefficient that varies dependent upon the stability of the atmosphere and is site dependent. The above equation is used for convenience, in non-complex terrain up to a height of about 200 m above ground level since it is assumed that the wind profile is reasonably well approximated. The power-law exponent for wind speed typically varies from about 0.1 on a sunny afternoon to about 0.6 during a cloudless night. The larger the power-law exponent the larger the vertical gradient in the wind speed. Although the power-law is a useful engineering approximation of the average wind speed profile, actual profiles will deviate from this relationship.

The wind module of the H<sub>2</sub>RES system is designed for accepting up to three types of wind turbines which may be located in two different wind parks. The conversion from wind velocities to electrical output is done using output graphs provided by manufacturers for wind turbine characteristics. These are also used to simulate power output from the turbines: Figure 9.

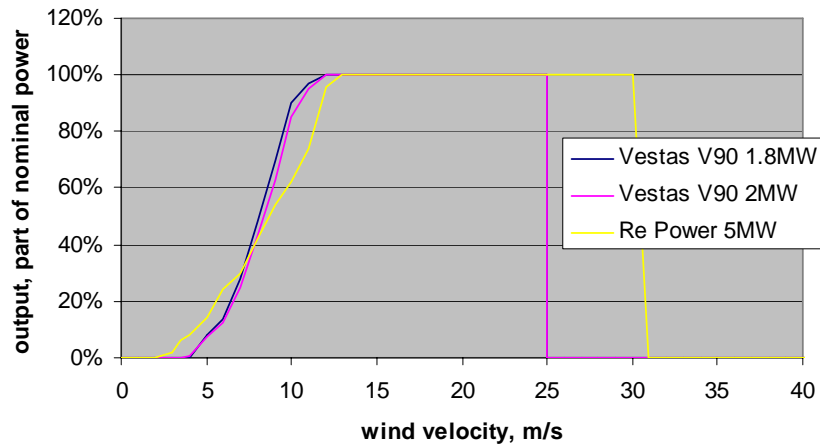

Figure 9: Actual data used for wind turbine outputs.

#### 2.4.2.2. The Solar module.

The hourly solar radiation is again obtained from the nearest meteorological station, or calculated by any of the available models for that purpose based on the given latitude. Data obtained from meteorological station is usually total radiation on horizontal surface. The solar module can use either data for solar radiation on a horizontal surface which then has to be adjusted for the inclination of PV array or it can use directly radiation on a tilted surface. The adjustment of solar radiation to the inclination angle is done by monthly conversion factors which are calculated by the RET Screen or the PV-GIS programme. The solar module converts the total radiation on the horizontal surface into the inclined surface if not already available, and then into the output. With the efficiency data obtained from the PV modules producer (inverter, line losses, etc.) it is then straightforward to calculate the hourly PV electrical output.

#### 2.4.2.3. The Storage module.

The present technological storage solutions include batteries, water pumped storage, flywheels, super conducting-magnets, pressurized-fluid systems and a set of an electrolyser and a fuel cell (Gaustad et al, 1992). Of these, only pumped storage and battery systems are commonly employed, the others are in various stages of research and development. The H<sub>2</sub>RES is a model that offers the possibility of different types of storage as indicated in Figure 8. There are three storage sub-

modules, one for each energy storage solution. The hydrogen storage module is based on an electrolyzing unit, hydrogen storage unit, and a fuel cell. The reversible hydro module is based on a water pump driven by wind energy, water storage and a turbine. Finally, the batteries module offering another way of storing energy. In this study however, only one storage solution was considered, that tackled in Scenario 3 utilizing the use of electrolyser and fuel cells for hydrogen and electricity production, respectively.

The input into the storage system is limited by the chosen power of the electrolyser, water pump or battery storage, meaning that the renewable excess power that is superfluous to one of these devices, or cannot be taken to the storage system because it is full, has to be dumped or rejected. This dumped energy can be sometimes be used for deferrable processes such as desalination of seawater or climatisation which are usually very important on islands lacking fresh water supply. The stored energy can be retrieved at any moment and converted into electricity.

The model envisages that the energy retrieval systems can be used in the peak time, for peak shaving, or whenever the renewable is not reaching the limit set. In this way it is possible to use more of the renewable electricity. The use of energy storage allows electricity generated during periods of high-availability/low-demand to be converted (to a storable energy-form) and stored for subsequent re-supply during periods of low availability/high-demand. This combination of supply-side management and demand-side management both maximizes utilization of the variable/intermittent resource and minimizes reliance upon “conventional” plant, being in the limit, the 100% renewable scenario. In the absence of storage, the variable/intermittent resource has to be matched by dedicated conventional capacity in order that supplies can be guaranteed. In order to fairly assess the energy storage economy, the hydrogen/ water/batteries stock difference between the beginning and the end of the yearly period should be negligible. To satisfy this condition, the stock at the beginning of the year is set to be equal to the stock at the end of the year. The principal components of an electrolyser-fuel cell system are an electrolyser, a means of gas storage (oxygen and hydrogen) and means of recovering the electrolytic gases to electricity, the fuel cell.

The storing facility is working with certain storage efficiency, which is around 50–80% for the electrolyser,  $\mu_{el}$ . The electrolyser is expected to produce hydrogen at a suitable pressure for storage, avoiding the need for compression. The storage vessel and the electrolyser output pressure limit the storage capacity. The stored hydrogen can be retrieved at any moment, either for use in stationary fuel cell or for mobile uses; so, it can possibly serve as a stepping-stone in converting even transport

to hydrogen. The fuel cell, with its given efficiency,  $\mu_{FC}$ , around 60%, can use the hydrogen from storage, and produce electricity that will be supplied to the grid.

In order to satisfy this condition, the stock at the beginning of the year should approach the stock at the end of the year. The energy accumulated in hydrogen storage in hour  $n$  is:

Equation 3: 
$$E_{H_2}^n = E_{H_2}^{n-1} - \frac{E_{FC}}{\mu_{FC}} - E_{H_2load} + \mu_{el} E_{el}$$

Which satisfies conditions that the hydrogen stored must be in the range between empty and full. In addition, the fuel cell will not be allowed to work in case that hydrogen storage stores less than hydrogen needed to supply hydrogen load for a set number of hours  $t_{H_2sec}$ :

Equation 4: 
$$E_{H_2}^{n-1} < t_{H_2sec} E_{H_2load} \Rightarrow E_{FC} = 0$$

#### 2.4.2.4. The Hydrogen load module.

The hydrogen load  $E_{H_2load}$ , which might stem from transport use, or from other demand, has to be given on per hour basis, for the whole period, in energy content units. According to the projected load growth and the base load, the required hourly load for each year is calculated and referenced to H<sub>2</sub>RES. In addition to this, a security of supply in hours is added to the required load. This ensures an availability of hydrogen.

#### **2.4.2.5. The Power Load module.**

The hourly load of the island power system has to be obtained from the local utility. This data is usually available in the so-called load duration curves (LDC) representation, in which load is sorted by magnitude instead of time. LDC curves are well suited for conventional energy planning, but cannot be used with intermittent sources when RES are to represent a significant part of the system, as are the cases of the proposed scenarios and the objective of this study. This is due to the fact that intermittent renewable sources give in any hour an output that is between 0 and the maximum installed capacity, which can be higher than the total load.

As a result the amount of renewable electricity taken by the power system can only be calculated comparing load and renewable output at least on hourly basis. In fact a system integrating large-scale RES and storage will have, when installed, to make decisions on an even smaller timescale, but for modelling purposes, as herein, hourly periods will represent reasonably well the real situation. If the wind is strongly changing, it might be necessary to adjust the model for 10 min periods. That is straightforward from H<sub>2</sub>RES model.

Typically autonomous energy supplies are based on renewable energies, such as solar and/or wind or ocean energy. According to Hashem, by selecting a time-step of one hour, it is assumed constant wind speed and solar radiation during each hour. This assumption (Hashem, 2000) does not have considerable effect on the general hourly response of the generating system since hourly average data were used. However, one should have in mind that both wind and solar radiation are highly intermittent, and therefore the variability in the power generated by the wind/PV generating systems is dependent on the stochastic nature of wind and solar radiation.

Therefore, assuming constant wind speed and solar radiation within an hour will not be entirely accurate if a more detailed response of the wind/PV generating system is of interest. In that case, using proper distribution curves, such as the Weibull distribution for wind, can use an approach to take the variability of the wind speed and solar radiation into account considering the stochastic distribution of wind and solar radiation. Using such distribution curves, the power generation within each hour can be corrected accordingly.

Small power systems usually have their power frequency controlled by a single block. Small amount of power coming from other sources will easily adjust to synchronous operation. It is safe to say that at any single hour, the maximum power that can come from sources without frequency control is around 30%. This percentage can be even more strengthened by installing active power

controlled variable pitch wind turbines, other frequency stable generating blocks such as PV and some kind of energy storage [40]. This allows for even higher values during smaller periods of time. Such a limit placed on renewable energy sources, will typically for wind, allow only 10-15% of the total yearly electricity produced which is basically the aim of such study.

The load module of H<sub>2</sub>RES model, based on a given hourly wind limit, accounts for the renewable electricity taken by the grid, and the excess is available for storage, desalination or some other kind of dump load. The still unsupplied load will be matched either from storage, or from Diesel engines. If there are hydro turbines installed, they would be first called, in case there is enough water stored in the upper reservoir. Fuel cells are called next, and batteries only in case that all other fail to cover all the demand. In case that the remaining load is under the technical minimum of the smallest diesel block, the diesel block would be set on technical minimum, and power coming from other sources would be reduced.

Equation 5: 
$$E_{load} = E_{I,t} + E_T + E_{FC} + E_{bat,out} - E_P - E_{el} - E_{bat,in} + E_D$$

Where  $E_T$ ,  $E_{FC}$  and  $E_{bat,out}$  are the outputs from the hydro turbines, the fuel cells and the batteries, while  $E_P$ ,  $E_{el}$ ,  $E_{bat,in}$  are the energy consumed by pumping water, electrolysing water and charging batteries, respectively.  $E_D$  is the output of the diesel blocks in use at that moment.

The intermittent renewable electricity taken by the system,  $E_{I,t}$ , is defined by the intermittent limit  $\varphi_I$ , and the intermittent potential,  $E_{I,pot}$ :

Equation 6: 
$$E_{I,t} = \text{MIN}(\varphi_I E_{load}, E_{I,pot})$$

Where intermittent potential is a sum of wind and solar PV potentials:

Equation 7: 
$$E_{I,pot} = E_{W,pot} + E_{PV,pot}$$

The total intermittent potential will be either taken by the system or used in pumps, by electrolyser or stored in batteries, and the remaining will be rejected:

Equation 8: 
$$E_{I,pot} = E_{I,t} + E_P + E_{el} + E_{bat,in} + E_r$$

Pumps should only work in their optimal point, while electrolyser should not be turned of and on frequently. Power of each block and switch on time will be a constraint to intermittent energy stored.



## 2.5. The financial approach

Energy related government entities, investors, policy makers and also to a certain extent final end users have always wondered what does it cost to produce a kWh of energy, either it being produced from conventional fossil fuelled sources or else from renewable energy sources. Apart from being able to get the money invested for such projects, it also helps the concerned entities to develop energy policies by shaping tax incentives, R&D policy and other measures. The introduction of taxes for the emission of carbon dioxide and other GHG gasses led to another factor in determining the actual cost of electricity which in past times was ignored. The introduction of “clean power” into a system with fossil fuelled power leads to a lot of variables that have to be carefully analysed. This becomes more complex when multiple investments over a projected period occur.

Different electricity generating costs models exist, the common ones being Capital Asset Pricing Model and Engineering Economics Approach. Using the CAPM, the required return or discount rate for asset j,  $R_j$  can be expressed as:

Equation 9: 
$$R_j = R_f + \beta(R_m - R_f)$$

Where  $R_f$  and  $R_m$  are the risk-free rate of return and the return to a broadly diversified market portfolio respectively, and  $\beta$  is a statistically derived covariance term relating the variability of asset j to the variability of the broadly diversified market portfolio [41]. On the other hand, the Engineering Economics approach rather than basing its rules on formulas, bases its rules on conditions, the most influent one being that of representing assets by their cash flows. These work reasonably well in an environment characterized by technological stasis and homogeneity [29]. The former though widely accepted for capital budgeting and project valuation, have not for a number of historical reasons been adopted for electricity planning and cost estimation whilst that the latter, being based around the time of the Model-T Ford fails to accurately quantify fossil price risk.

## 2.6. Kyoto Protocol

In 1997, almost 200 countries signed the Kyoto Protocol to the Climate Convention with the objective of "stabilization of greenhouse gas concentrations in the atmosphere at a level that would prevent dangerous anthropogenic interference with the climate system. [43]" Kyoto Protocol states that GHG emissions have to be reduced by about 6% of 1990 levels between 2008 and 2012. Higher percentages are placed for periods after. Developed countries or as more commonly known Annex 1

countries (Parties that were members of the OECD- Organisation for Economic Co-operation and Development- in 1992, plus countries with economies in transition -the EIT Parties-, including the Russian Federation, the Baltic States, and several Central and Eastern European States) may meet their targets through a combination of domestic climate change activities and the use of the Kyoto Flexible Mechanisms. These flexible mechanisms allow developed countries to achieve part of their obligations by investing or implementing projects that reduce green house gases in other countries. The principal mechanisms are:

- Clean Development Mechanism (CDM): allows developed countries (Annex 1 countries to the UNFCCC also referred to as Annex B to the protocol) to gain emissions credits for financing projects based in developing countries (non-Annex 1 countries). The term used for this credit is known as Certified Emission Reductions (CERs).
- Joint implementation (JI): is similar to CDM, however this is done between two Annex 1 countries. The term used for this credit is Emission Reduction Units (ERUs).
- Similarly to the above, Directive (2003/87/EC) puts in place “cap and trade” framework for emissions and emissions control. The Directive creates an Emission Allowance Unit (EAU) or EU allowance (EUA) and establishes a permitting scheme for participating installations [44]. The purpose of this permit is to place an obligation on each operator. A feature of this Directive is that it encourages the linking of EU ETS with other similarly rigorous emission trading schemes in non-EU Annex 1 Countries, in particular those that ratified the Kyoto Protocol.

### **3. Description and Overview of the Malta Case.**

The Maltese archipelago is centrally located in the Mediterranean Sea and comprises six small islands. The main islands are Malta, Gozo and Comino (Figure 10) all of which are inhabited, while the islets of Filfa, Cominotto and St.Paul's Islands are uninhabited.

The Maltese islands cover a total area of 320 km<sup>2</sup> with a total coastline perimeter of approximately 140 km. Malta's geographic co-ordinates are 35 50 N and 14 35E. The central position of the landmass is approximately 1,840 km east of the Straits of Gibraltar and about 1,520 km northeast of the Suez Canal. Malta is 93 km south of Sicily and 290 km north of the African Continent. Malta's land area totals 246 km<sup>2</sup>. The general topography of the island can be described as a series of low hills in the northern area with terraced slopes and plains on the southern aspect. It is mostly low, rocky, flat to dissected plains and with many coastal cliffs. There are no mountains or rivers. Gozo is the second largest island and lies about 6 km northwest of Malta. The total land cover is about 67 km<sup>2</sup> with a coastline perimeter of 43 km. The topography is similar to that of Malta[45]. 37% of the surface area of mainland Malta and 35% of the Maltese Islands are under agricultural use even though agricultural activities play a very modest role in the Maltese economy, being responsible for only same 3% of the total Gross Domestic Product (GDP) and employing 3% of the gainfully occupied population [28].

#### **3.1.1. Population**

With a current population of almost 398,534 Malta has one of the highest national population densities in the world. The present population growth rate is in the region of 0.75% according to UNFCC report [46]. This small annual increase in the net population is primarily sustained by high life expectancy and a low emigration rate. Furthermore, population density is accentuated by the annual inflow of tourists, which is equivalent to about 30,000 additional residents.

#### **3.1.2. Climate**

The climate of the Maltese archipelago is normally described as typically Mediterranean, with moist, mild winters and dry, hot summers. The average annual precipitation is about 530 mm and is mainly restricted to very short periods in the autumn and winter. The air temperature generally ranges between 9.5°C and 33°C, exceptional extremes of 1.4°C and 43.8°C have been recorded. The hottest period of the year runs from mid-July to mid-September and the coldest months are January and February. The sea temperature varies in conformity with the air temperature, with a



### **3.1.4. Economy**

Possessing few indigenous raw materials and a very small domestic market, Malta has based its economic development on the promotion of tourism and labour-intensive exports. Since the mid-1980s, expansion in these activities has been the principal engine for strong growth in the Maltese economy. Investment in infrastructure since 1987 has stimulated an upswing in Malta's tourism economic fortunes. Malta is highly dependent on foreign trade and services. The only abundant natural resource is limestone, which is used in the construction industry. The most important asset in the Maltese economy remains the human resource.

### **3.1.5. Industry**

The main industries besides tourism include electronics, ship construction and repairs, food manufacture, textiles, footwear, clothing, beverages and tobacco. Over 180 international firms operate locally and 77% of exports are to the European market. The principal trading partners are Italy, Germany, the United Kingdom and the United States.

### **3.1.6. Energy**

#### **3.1.6.1. Transport.**

As reported by the Maltese national statistics office [47], at end September 2007, the stock of licensed motor vehicles stood at 285,353. Of these, 76.0 per cent were private vehicles, while commercial vehicles made up 16.3 per cent. The kilometres travelled yearly is further on calculated in section 4.1.3. This gives an indication that in Malta every two persons have one car. Efforts have been made in Malta to reduce the emissions from transport by introducing vehicle roadworthiness test (V.R.T) and eliminating leaded fuel. The public transport gains no positive reputation in Malta and the use of other means of transport except motorcycles in Malta is not utilised.

#### **3.1.6.2. Power system.**

The power system is further elaborated in section 3.2

#### **3.1.6.3. Energy Utilisation in Buildings.**

Energy utilisation in buildings is greatly influenced by the climatic conditions and structural designs of the buildings. The climatic conditions in the Maltese Islands are further on described in section 3.1.2. In Malta, the main user of electrical power is the domestic sector (36%), followed by the

commercial sector (30%), the industrial sector (25%) and the water production sector (9%) [46]. This is similar to what is experienced in EU countries, with the building sector consuming a total of 40% of the total energy consumed in EU countries [48]. Although domestic thermal comfort lies on the bottom scale of energy consumption when compared to other power and transport necessities, the domestic sector is a very sensitive one. It is prone to significant increases in energy consumption with further improved standards of living, given the changing climatic conditions and the present poor performance of local buildings [49]. The argument is further justified with the steep rate of installation of air conditioning systems for domestic use. These are mainly used for cooling in summer time however their use is also sometimes extended to few days of heating in winter. The level of humidity also leads to the need of thermal comfort especially at the end of the summer period when south east winds bring with them a humid warm air. The building traditions in Malta do not quite well help in energy efficiency in buildings. Since the need for heating is not high, the necessity of insulation, double glazing for winter is not much requested. However, this counter effects cooling in summer where much more energy is needed in order to keep the building thermally comfort. The traditional building block is the globigerina limestone which due to its porosity contributes to high indoor humidity. The roof is usually exposed to all elements and not correctly insulated. By such practices, there is more space utilisation, however, there is also a greater surface area through which heat exchange occurs especially during summer time with mean of 5 kWh/m<sup>2</sup>/day. The accent on wells for water capture is quite well accepted in the Maltese mentality and this helps in the reduction of the use of water obtained from the expensive reverse osmosis process. Legislations and regulations regarding efficient building has never been taken seriously until lately when guidelines [50] and the Energy Directive for energy use in buildings (2002/91/EC), were lately published [51]. These will help to improve the overall building efficiency if correctly implemented and enforced. Energy conservation measures in the domestic sector can mean substantial savings of energy without any loss of comfort.

### **3.2. Malta's Power system**

Malta has no indigenous conventional energy sources. The production of primary energy in Malta is fossil fuel based. The Maltese national electricity grid is an isolated one and is not yet (2007) connected to any other electrical network. Therefore, all the electrical energy that is required is generated in Malta. This is carried out by Enemalta Corporation (EMC). Electricity is generated by two inter-linked power stations, one at Marsa on the eastern part of Malta and a more recent plant at Delimara on the southern coast with a total combined nominal installed capacity of 571 MW. The generators operate at different levels of efficiency (Figure 11). The main user of electrical power is

the domestic sector (36%), followed by the commercial sector (30%), the industrial sector (25%) and the water production sector (9%). The cost of imported energy represents most of the country’s total domestic exports. Therefore, it is obvious that energy is of vital importance to the island’s economy and that the cost of imported energy is and will continue to be an increasing burden on the economy of the country. Section 3.2.1 to 3.3.5 is the current generation situation as described by Enemalta (electrical generating utility) [52].

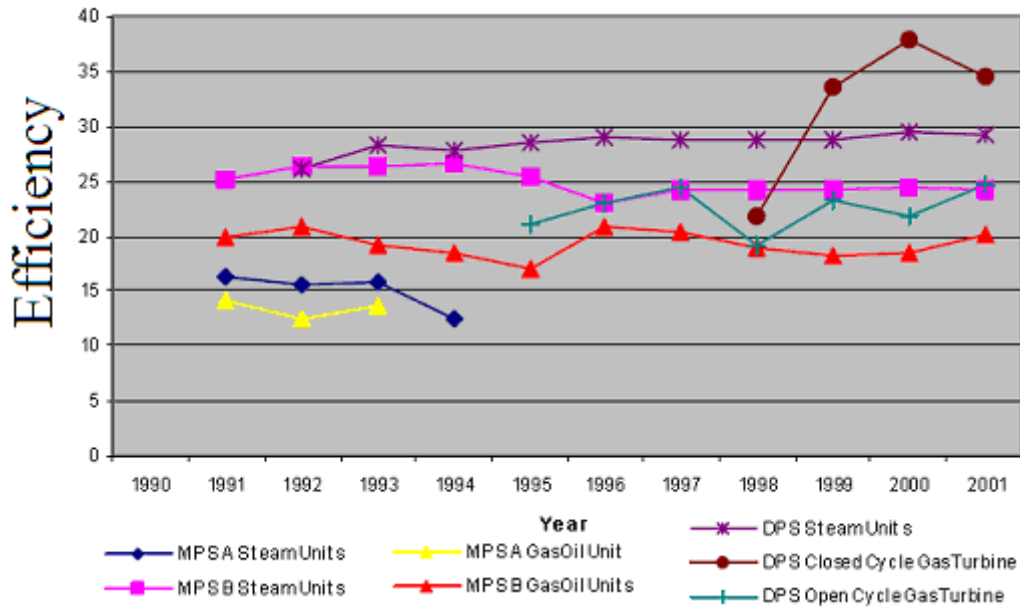

Figure 11: Efficiencies of individual units at Marsa and Delimara Power Stations [53].

### 3.2.1. Delimara Power Station

This station is situated in the south easterly part of the island and was first commissioned in 1992 and consists of the following:

Table 9: Delimara power generating units [52].

Units	Commissioned
2 x 60 MW Conventional Steam Blr/Tur Units	1992
2 x 37 MW Open Cycle Gas Turbines	1994
1 x 110 MW Combined-Cycle Plant. 2 x 37 MW GTs, 2 x HRSG, 1 x 36 MW	1999

The total generation capacity of this station stands at 304 MW. The steam units burn 1% sulphur fuel oil, while the gas turbines and the Combined Cycle, burn distillate fuel oil.

### 3.2.2. Marsa Power Station

This station is situated at the Marsa end of the Grand Harbour. The original station ('A' Station) was built underground beneath Jesuit Hill and was commissioned in 1953. The plant installed in this station consisted of 3 steam units with a nominal capacity of 5 MW each. These units were supplied under the Marshall Aid Programme.

Due to the increasing demand of the Maltese nation, this station was later expanded and final total capacity was 30 MW which was built up of 5 steam units each rated at 5 MW and a gas turbine of similar rating. The station was finally de-commissioned in 1993.

In 1966, the first two units at 'B' Station were commissioned. This station was later expanded in order to meet the electrical load and presently is made up of the following plants.

**Table 10: Marsa power generating units [52].**

Units	Commissioned
2 x 90 Ton/hr Steam Boilers* 2 x 10 MW Steam Turbines	1966
2 x 120 Ton/hr Steam Boilers	
2 x 30 MW Steam Turbines	1970
1 x 130 Ton/hr Steam Boilers 1 x 30 MW Steam Turbines**	1982
1 x 130 Ton/hr Steam Boilers 1 x 30 MW Steam Turbines**()	1984
1 x 300 Ton/hr Steam Generator	1985
1 x 30 MW Steam Turbine**()	1987
1 x 60 MW Conventional Steam Blr/Tur unit***()	
1 x 37 MW Open Cycle Gas Turbine	1990

- The steam generators were decommissioned in 1994 and 1999 respectively.\*\* The steam turbines are refurbished plants, which were first commissioned in 1952 at Palermo in Sicily.
- \*\*\* The steam turbine is a refurbished plant, which was first commissioned in 1954 at Little Barford in the UK. In 1996, this unit was refurbished again to extend its lifetime for a further 15 years.
- These units were run on coal between their respective commissioning date and 1995 when coal firing was stopped.



Total generation capacity of this station stands at 267 MW. All the steam units presently burn 1% sulphur fuel oil and the gas turbine burns distillate fuel oil.

### 3.2.3. Load profile

The daily electricity demand for the Maltese Islands exhibits a profile that is typical of the Mediterranean area. Peak demand in winter is during the evening and is therefore predominantly domestic. In summer the peak demand occurs during the morning and therefore predominantly commercial and industrial (Figure 14).

### 3.3. Data Collection and Analysis

Obtaining the data for generated electricity was not that difficult since there is only one generating utility in Malta. Enemalta Corporation collaborated willingly to provide data. Generated Power (Figure 12) together with peak demands (Figure 13) are presented. Further more hourly data for different years were also made available. From all this, the data could be analysed and future demand predicted.

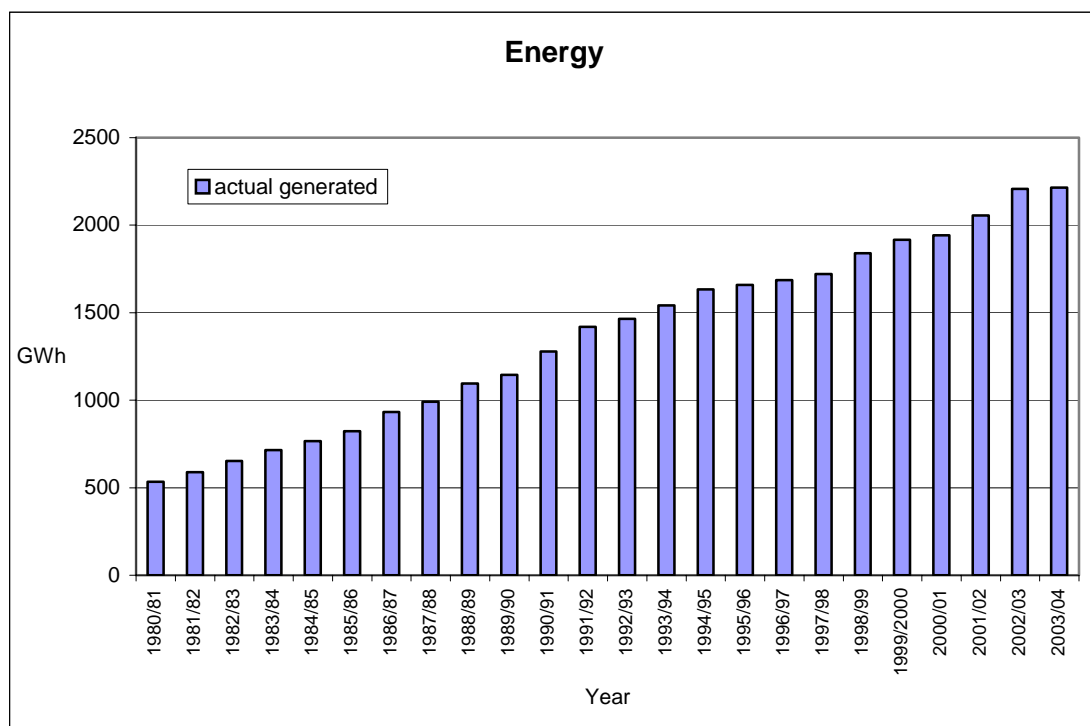
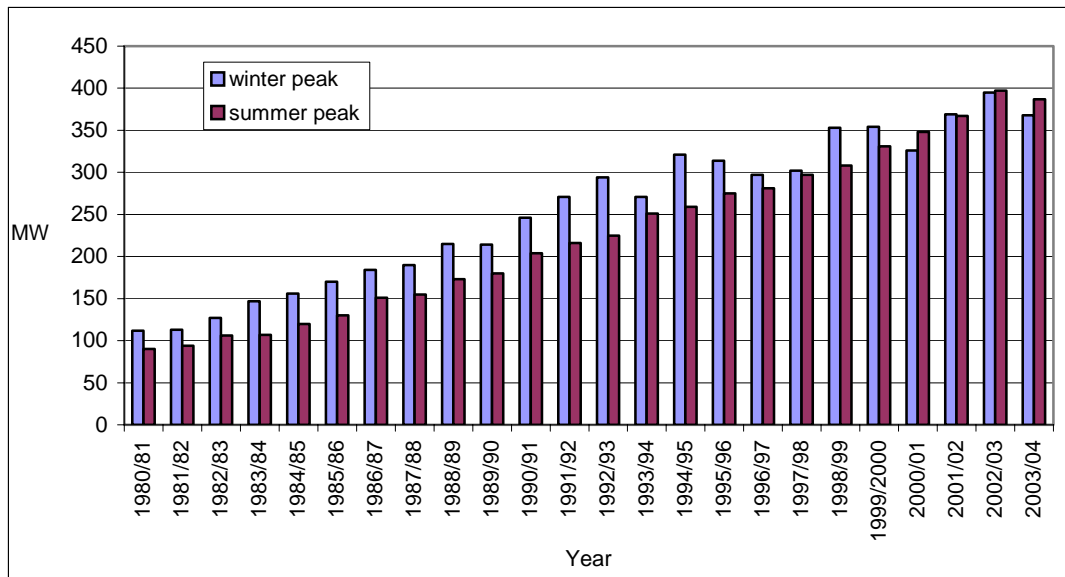

Figure 12: Generated power up to year 2005



**Figure 13: Summer and winter peaks up to year 2005.**

Inspection of the results shows a growing increase in electricity demand. However the electricity demand in 2003 might be considered abnormally high as a result of the particularly cold winter and hot summer in Malta. Further more the 2004 drop in electrical demand could be the result of pre-EU accession economical crisis. In fact it is estimated that there is usually some sort of economical crisis every ten years. Approximately every decade the economy takes a downturn. This is stated to be a crisis of overproduction that is inevitable in a capitalist society.

Projections as to future load growth are based on extrapolations of electricity demand from historic data over the base period 2000 to 2004. This study load projection uses a “trend method” technique. In this method, the variable to be predicted is purely expressed as a function of time, rather than by relating it to other economic, demographic, policy and technological variables. Different growth rate scenarios were analysed in this thesis. These varied from yearly to seasonal, daytime to night time, working days to off days. However after an evaluation of all the results it was decided to model our system with two growth rates, one for the summer period and one for the rest of the year. This takes into consideration that summer peak growth is higher than winter peak growth due to hot and humid summers. Thus the inevitable trend of introducing more air- conditioning systems will further load the generation system. The yearly load growth rate demand up to year 2025 was set to be 6.5% for the summer period whilst that for the rest of the year was set to be 3.73%. Thus the overall average yields to 4.4%. The overall average compares to that estimated by [53] being 4% presented in Table 11. The growth rates were obtained for summer periods and rest of the year periods. This was done by averaging the load growths obtained between 2004 and 1999 and

between 2004 and 1999 but minimising 2003 and 2004 effects since the former was considered a very hot unusual year whilst the latter was considered a pre EU accession economical crisis.

This result also indirectly models the tourism industry needs, especially during summer time, which is estimated to continue to grow whilst it also depicts that such an economic crisis as that experienced in 2004 will not happen again. Furthermore, Malta is forecast to be amongst the strongest in population growth amongst the new Member States, according to Eurostat, the official European Union (EU) statistics agency. The report indicates that Malta will be the third highest EU Member State to experience a population increase, which is expected to be in the order of 27.1 per cent between 2004 and 2050. This will surely have an increasing effect on the load demand.

A base year had to be chosen in order to model the growth. This was chosen as being the most regular year over the last period. This was year 2002. From there, H<sub>2</sub>RES load module was used to extrapolate the peak load for the year and the load demand for the coming years until 2025, ten year load estimation. Projections of total demand over the period 2005 to 2007 are 7,478,535 MWh compared to Enemalta projections of 7,317,358 MWh. These assume a different summer and rest of year load growth, a deviation of about 2%. The actual demanded load for period 2005 to 2007 was 6,817,886 MWh [54] assuming that the load demand of November and December 2007 were equal to October 2007, since these are not yet published. This leads to a deviation of about 8% over projected values. However, one has to consider that year 2007 periods was particularly characterised by very mild winter, whilst that summer periods in years 2005-2007, were as well particularly mild thus reducing the overall load demand.

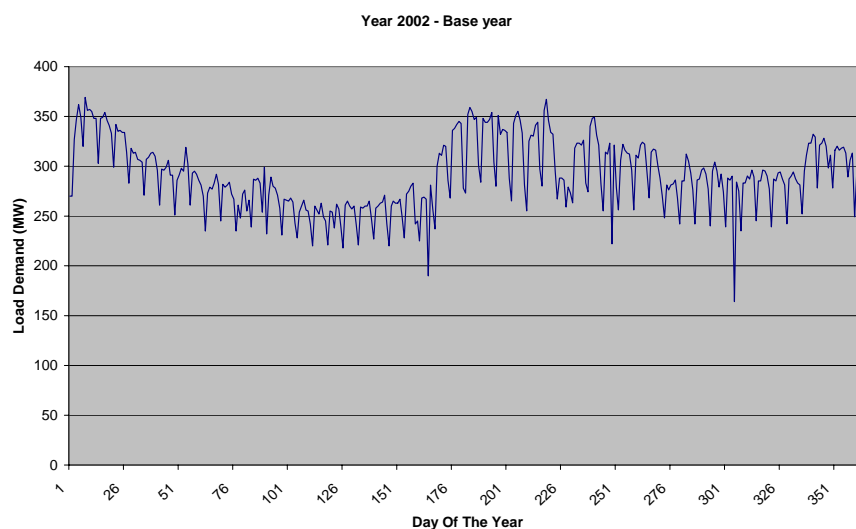

**Figure 14: Base year load variation**

Figure 15 shows the predicted load demand till the year 2025. Four load variations are shown, year 2002 being the reference load year and the other three: 2009, 2015 and 2025 being the projected ones.

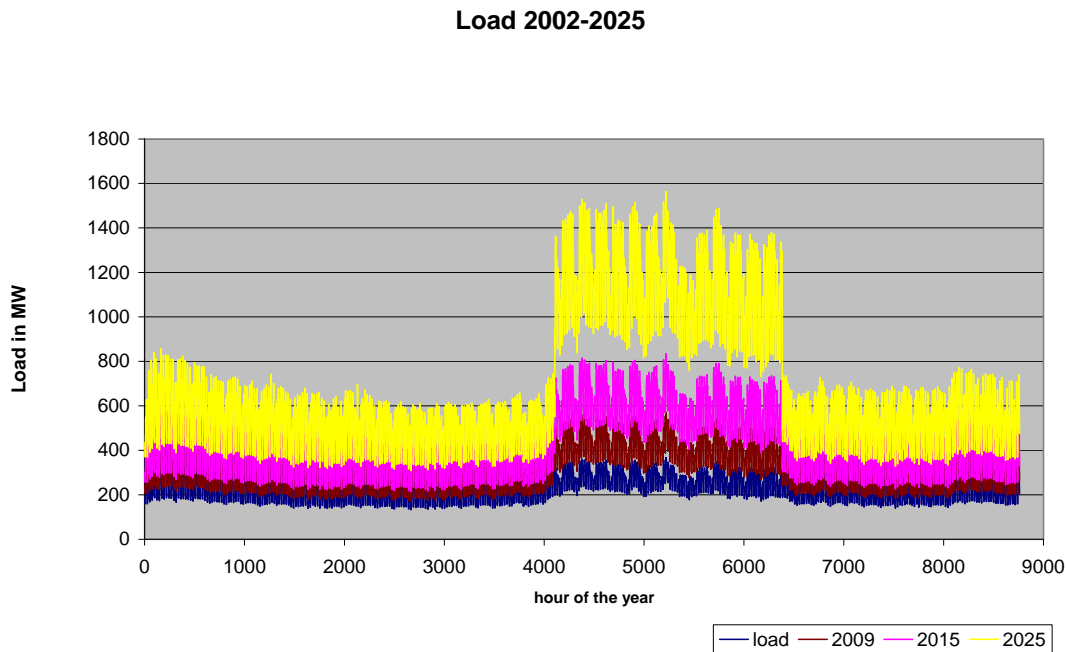

**Figure 15: Base year 2002 with projected load growth applied until year 2025**

### 3.3.1. Malta load growth rate and future load demand.

This part of the study is a comprehensive evaluation of existing demand and estimates future load growth. It aims to show the actual load and load growth through history, thus predicting future load and peaks. The study benchmarks the calculated projections to one lately presented in the National Allocation Plan (NAP) for Malta [53]. Such a comparison is always a healthy one because usually different forecasting techniques are used.

This study load projection uses a “trend method” technique. This method falls under the category of the non-causal models of demand forecasting that do not explain how the values of the variable being projected are determined. Here, we express the variable to be predicted purely as a function of time, rather than by relating it to other economic, demographic, policy and technological variables. The trend method has the advantage of its simplicity and ease of use. However, the main disadvantage of this approach lies in the fact that it ignores possible interaction of the variable under study with other economic factors such as GDP growth and electricity prices change.

On the other hand, the study presented in the NAP uses a hybrid combination of “Econometric Approach” and “Time Series” methods. The former approach combines economic theory with statistical methods to produce a system of equations for forecasting energy demand. The dependant variable, in this case, demand for electricity, is expressed as a function of various economic factors. These variables could be population, income per capita, GDP or other similar values. The latter approach is essentially econometric models where the only explanatory variables used are lagged values of the variable to be explained and predicted. The essential prerequisite for a time series forecasting technique is data for the last 20 to 30 time periods.

### 3.3.2. Analysing NAP predictions.

As described above, the NAP [53] uses a hybrid combination of “Econometric Approach” and “Time Series” methods. The dependant variable, electricity, is expressed as a function of various economic factors and constants. These variables are GDP, the year and three constants. In this approach, it is assumed that a Business as usual scenario is employed.

The correlation identified using regression analysis (best fit) is :

$$\text{Equation 10: } D = [C_1 \cdot Y] + [C_2 \cdot G] + B$$

Where

$D$  = Annual Electricity Demand (MWh)

$C_1$  = constant = + 98,279.12

$Y$  = Year (e.g. 2002)

$C_2$  = constant = - 656.726

$G$  = GDP at 1995 prices (million Lm)

$B$  = constant = - 193,731,650

In the NAP it is stated that the correlation based on this equation provides a smoothed relationship that is a good fit to the Enemalta data over the base period 1995 to 2003 (Figure 16). Based on the correlation, projections of total demand over the period 2005 to 2007 are 7,312,327 MWh (Table 11). This is very similar to Enemalta projections of 7,317,358 MWh, which assume an increase in demand of 4% per annum over the plan period.

Table 11: Electricity demand, GDP and time. (Projections in italics) [53]

1	2	3	4	5	6	7
Year	GDP @ 1995 Prices (million Lm)	% Increase in GDP	Electricity Demand (MWh)	% Increase in Elec. Demand	Elec. Demand Based on Correlation (MWh)	% Increase in Elec. Demand
<i>Base Period</i>						
1995	1,146	n/a	1,603,196	n/a	1,582,919	
1996	1,191	3.99%	1,654,696	3.21%	1,651,185	4.31%
1997	1,249	4.85%	1,703,682	2.96%	1,711,504	3.65%
1998	1,292	3.43%	1,733,554	1.75%	1,781,675	4.10%
1999	1,344	4.06%	1,854,151	6.96%	1,845,541	3.58%
2000	1,429	6.30%	1,914,016	3.23%	1,888,192	2.31%
2001	1,413	-1.11%	1,988,226	3.88%	1,996,918	5.76%
2002	1,445	2.25%	2,057,301	3.47%	2,074,314	3.88%
2003	1,420	-1.72%	2,235,541	8.66%	2,188,886	5.52%
2004	1,435	1.07%	2,253,947	0.82%	2,277,176	4.03%
<i>Plan Period</i>						
2005	1,460	1.70%	2,344,105	4.00%	2,359,433	3.61%
2006	1,490	2.10%	2,437,869	4.00%	2,437,583	3.31%
2007	1,522	2.10%	2,535,384	4.00%	2,515,311	3.19%
<i>Total (PP)</i>	<i>4,471</i>		<i>7,317,358</i>		<i>7,312,327</i>	

Base Projection of Electricity Demand (D, in MWh)

Based on correlation linking demand, year and GDP:  
 $D = (98,279.12 \times Y) - (656.726 \times G) - 193,731,650$

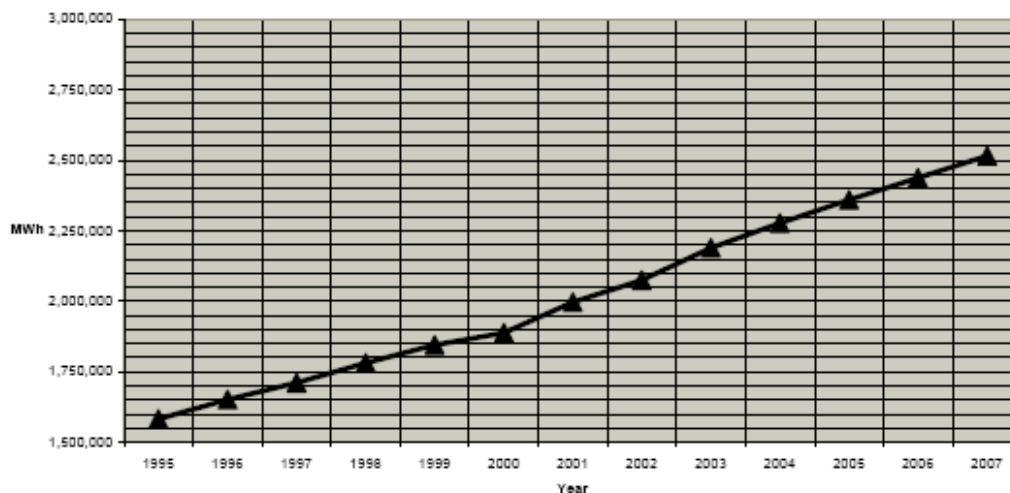

Figure 16: Base projection of electricity demand (from correlation) [53]

Though the NAP seems to be more accurate in predicting the base load expectations, it was still decided to use the two different growth rates i.e. 6.5% for the summer period whilst 3.73% for the

rest of the year. This was decided because in this analysis there was a special emphasis to cover peak loads and peak load growth. This is not covered or else not mentioned in the NAP.

### 3.3.3. Rate of growth of transport and Hydrogen load for transport.

The third scenario takes into account measures for greenhouse gas reduction in road transport sector proposed in Malta's Action Plan on Climate change. This includes 30% instantaneous penetration of intermittent renewables and hydrogen production from wind and solar sources satisfying the 5% of transport demand in 2015 and 10% in 2025.

In order to tackle this scenario, some extensive data research was necessary. This data had then to be manipulated in order to obtain other necessary information. First and foremost it was necessary to extrapolate the rate of fuel growth for transport. Data was obtained from an indicator fact sheet [55].

**Table 12: Final energy consumption by transport [55].**

Unit:	Mtoe (million tonnes of crude oil equivalent)							
	1990	1995	1996	1997	1998	1999	2000	1990/2000
Bulgaria	2 476	1 962	1 805	1 647	1 912	1 942	1 817	-27 %
Cyprus	645	750	755	771	809	830	852	32 %
Czech Republic	2 804	2 829	3 690	3 836	3 818	4 070	4 099	46 %
Estonia	839	490	531	684	576	579	577	-31 %
Hungary	3 015	2 653	2 658	2 784	3 068	3 257	3 251	8 %
Latvia	526	738	728	722	702	688	690	31 %
Lithuania	1 928	1 026	1 120	1 247	1 310	1 170	1 048	-46 %
Malta	221	291	341	346	321	335	319	44 %
Poland	7 338	8 244	9 256	9 637	9 509	10 566	9 250	26 %
Romania	4 417	3 207	4 077	4 205	3 920	3 147	3 421	-23 %
Slovakia	1 676	1 509	1 381	1 583	1 594	1 602	1 549	-8 %
Slovenia	928	1 326	1 497	1 517	1 377	1 311	1 313	42 %
Turkey	9 351	11 89	12 561	11 875	11 070	11 555	12 165	30 %
AC-10	19 919	19 855	21 958	23 128	23 083	24 407	22 948	15 %

NB: Final energy consumption by transport comprises energy consumption by road, rail, inland waterways, aviation and oil pipelines.

Source: IEA, 2003.

Using the available data, a load growth of 44.34% was experienced between the period 1990 and 2000. However, this incorporates both road and aviation transport. Thus, it was important to segregate the percentage in order to obtain the value for road transport only. This segregation was also available in the same report (Table 13) where it was tabulated that as a percentage, Malta uses 65.5% of its fuel for road transport compared to 34.5% used for aviation transport. No fuel is used for rail transport in Malta due to the inexistency of this mode of transport.

Table 13: Distribution of final energy consumption in 2000 [55].

Unit: %	Road	Aviation	Rail
Bulgaria	90.2	5.5	4.3
Cyprus	65.8	34.0	0.2
Czech Republic	87.9	4.9	7.2
Estonia	87.2	3.8	9.0
Hungary	87.8	6.9	5.3
Latvia	85.0	3.9	11.1
Lithuania	90.3	2.6	7.2
Malta	65.5	34.5	0.0
Poland	90.2	4.0	5.8
Romania	82.4	4.0	13.6
Slovakia	94.6	0.0	5.4
Slovenia	96.4	1.9	1.7
Turkey	87.2	10.5	2.2
AC-10	88.6	5.6	5.7

Source: IEA, 2003.

Using the data available it was possible to calculate the fuel for road transport in year 2000. This amounted to 65.5% of 319 Mtoe leading to 208.945 Mtoe. However it is also indicated that throughout the period 1990-2000, Malta experienced a 40% change in road energy consumption (Figure 17). Thus the annual Mtoe in 1990 could be determined – 149.25Mtoe. Thus the initial and final consumption for the ten year period was made available.

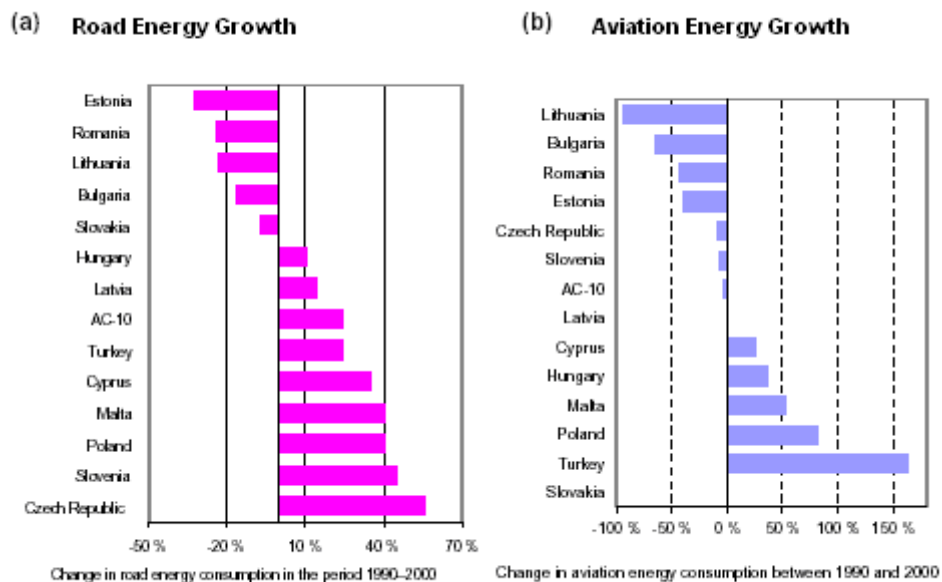

NB: For Slovakia, the reported amount of aviation energy consumption is zero.

Figure 17: Growth in energy consumption between 1990 and 2000 [55].



In order to obtain the year 2000 values from the 1990 values, an annual growth rate of approximate 3.45% had to be applied. Thus a 3.45% fuel transport growth was set after being calculated. This percentage was then applied to the available Mlitres consumed in 2003 (Report on the implementation of Directive 2003/30/EC (Biofuels) - 30 September 2004 – Ministry for Resources and Infrastructure. Thus the 2003 values were set as a base year for the calculation of fuel consumption up to 2025.

**Table 14: Use of transport fuels in Malta 2003 [56].**

	Mlitres	Energy Content MJ/l	TJ	% of total
Petrol	90.00	31.2	2808	47%
Diesel	90.40	35.7	3227	53%
Total fuel sales	180.40		6035	100%
Biodiesel	0.03	32.8	1	0.02%

After obtaining the predicted number of Mlitres up to year 2025, it was more practical to transform into its equivalent number of kilometres. A typical consumption rate of 7.5 litres for gasoline engines and 7 litres for diesel engines per 100 km was applied ending up with figures, graphically presented below.

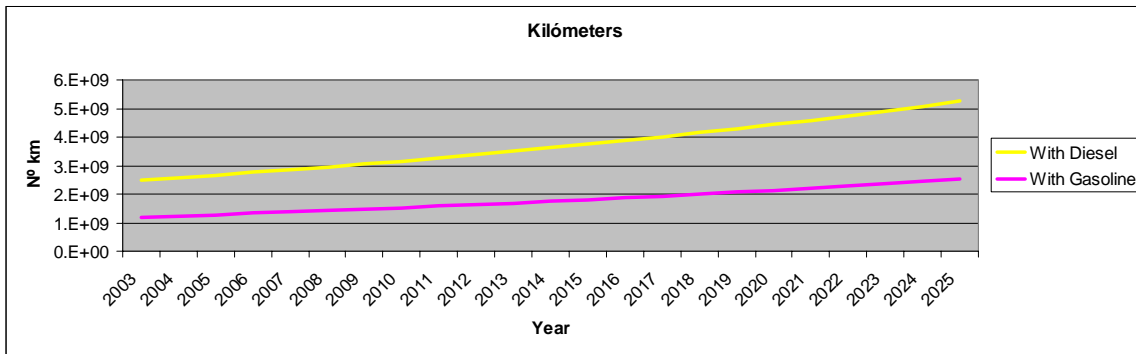

**Figure 18: Estimated load growth in kilometres travelled.**

The yearly percentage hydrogen fuel needed was set in order to gradually reach the 10% of the total kilometres to be covered by hydrogen fuel produced from Renewable energy sources.

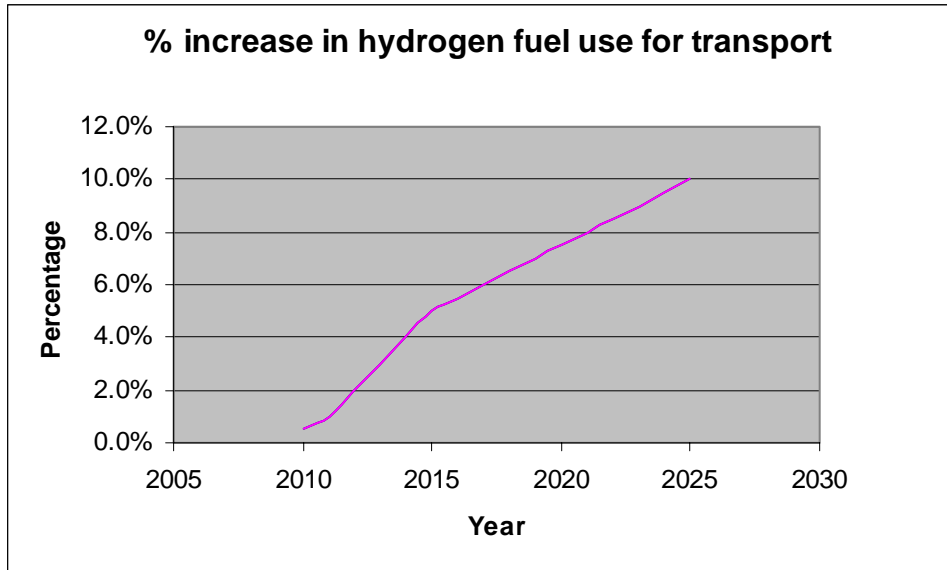

Figure 19: Projected increase in hydrogen fuel use

Approximate hydrogen fuel consumption of 1.5 kg of hydrogen for 100 km and an energy content of 120 MJ/kg was considered. Thus, in order to travel 100km of distance using 1.5 kg of hydrogen gas, one will be using 180 Mega joules of energy which is equivalent to 50 kWh. The latter units are in line with the units used in common practice. Thus the necessary production of hydrogen gas in kilowatt-hours in order to fulfil the 10% transport by year 2025 could be depicted.

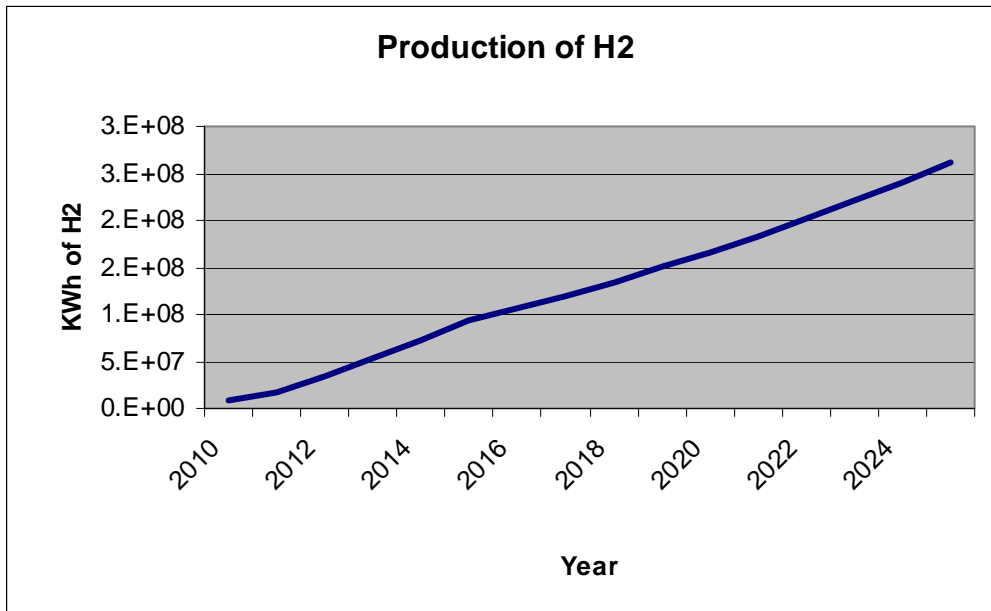

Figure 20: Hydrogen production necessary in order to cover projected hydrogen load.

From the above calculations and data available, it was possible to predict the CO<sub>2</sub> emissions from cars saved using technology under this scenario. Using a typical 0.20kg of CO<sub>2</sub> emitted gas per km

travelled, the CO<sub>2</sub> saved as a function of distance projected to be covered by hydrogen transport could be calculated (Figure 69). This, although will not be the main solution for reducing CO<sub>2</sub> emissions will greatly help in international efforts to reduce green house gas reductions.

### 3.3.4. Current Price of Electricity

At the moment the price of electricity in Malta is related to the type of business being domestic, commercial or industrial and the number of persons in case of domestic. Further more, the consumed electricity is divided in blocks and the consumer pays different tariffs for the different blocks. A fuel surcharge is then added according to fuel cost price fluctuations. The following are the rates applied to consumers [57]:

#### ➤ Domestic

Meter and consumption charge on the first 600 units – LM12.00 / € 27.95 per year.

Second block varies according to number of persons in the household:

1 person	– 800 units	@ 2c / € 0.05
2 persons	– 1,050 units	@ 2c / € 0.05
3 persons	– 1,375 units	@ 2c / € 0.05
4 persons	– 1,800 units	@ 2c / € 0.05
5 or more persons	– 2,350 units	@ 2c / € 0.05

Third block up to a total of 6,400 would be at 4c / € 0.09 per unit. Third block is equivalent to the difference between 6,400 units per year and the sum of the first and second blocks for each household. Consumption above 6,400 units per year is charged at 4c5 / € 0.105 per unit.

#### ➤ Commercial

Meter and consumption charge, on the first 200 units: LM24.00 / € 55.90

Over 200 units – 3c7 / € 0.086 per unit for all this sector except for licensed hotels and guest houses with the N.T.O.M.. The charge for over 200 units is 3c6 / € 0.084 per unit.

Customers with capacity of above 100 Amps per phase can opt to be changed on kVAh @ 3c4 / € 0.079 and 3c3 / € 0.077 per kVAh respectively.

➤ Industrial

Meter and consumption charge, on the first 200 units: Lm 24.00 / € 55.90 Maximum demand charge – LM 8.00 / € 18.63 per kw per annum. Consumption – 2c8 / € 0.065 per unit.

Special day / night and kVA rates are available for heavy consumers exceeding 5 million kWh units per annum @ 2c5 / € 0.058 per day unit and 2c3 / € 0.054 per night unit plus Lm 6.70 / € 15.61 per kVA. Customers with capacity of above 100 Amps per phase can opt to be charged on kVAh and kVA - rates 2c6 / € 0.061 per kVAh and Lm7.50 / € 17.47 per kVA per annum. Customers with special day / night tariff can opt for kVAh at 2c4 / € 0.056 per day unit and 2c2 / € 0.051 per night unit plus Lm 6.70 / € 15.61 per kVA.

#### Fuel surcharge

A fuel surcharge on the billed consumption of water and electricity is added to the bill. This surcharge has been set at 47.5% as from the 1st January 2006 and is to be revised on a bi-monthly basis to reflect international fuel price fluctuations. The fuel surcharge is capped for certain accounts.

Although this different type of pricing, [58] provides an average pricing for standard household consumer and for standard industrial consumer for the EU countries including Malta. These stand at 9.49 c€ and 7.11 c€ respectively. This is different from that calculated in Figure 53, however one has to note that at the moment electricity in Malta is subsidised. “Enemalta actually loses money on electricity generation, but it makes a big profit on sales of petrol.”[59]. In fact, in a report published by [60] it is stated that the actual cost of electricity for Enemalta in year 2005 was 5.98 Lm cents per kWh. With a euro conversion set to 0.4293, this is equivalent to 13.9297 c€ which is very comparable to that estimated in this studies.

### **3.3.5. Carbon dioxide emissions**

The following table shows typical emissions during various years. The latest report for total carbon dioxide emission for year 2006 states that 1,175,288 tons were emitted from Marsa power station and 810,477 tons from Delimara Power Station. 2,261,189 MWh were generated at the power stations, hence 0.8782 kg CO<sub>2</sub> were emitted for every kWh generated. Similarly an overall of 0.87

kg of CO<sub>2</sub> are emitted for every kWh (unit) generated in year 2005 [52]. Other recorded emissions for both carbon dioxide and other GHG are presented in Figure 21, Figure 22 and Figure 23 presented by [46].

Table 15: Emissions of CO<sub>2</sub> during last three years from the two power stations [52].

	Year 2004	Year 2005	Year 2006
<b>Marsa Power Station</b>	1,145,744 tonnes	1,159,927 tonnes	1,175,288 tonnes
<b>Delimara Power Station</b>	875,503 tonnes	811,331 tonnes	810,477 tonnes
<b>Total</b>	2,021,247 tonnes	1,971,258 tonnes	1,985,765 tonnes

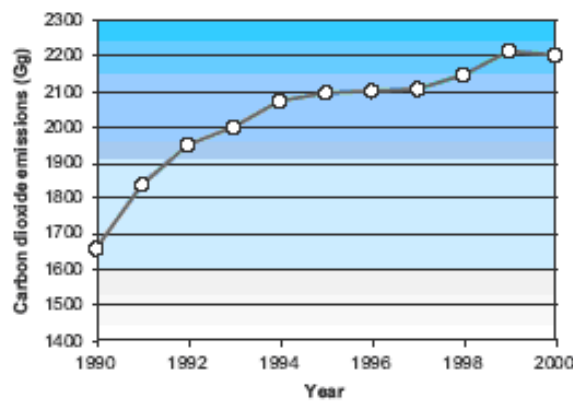

Figure 21: CO<sub>2</sub> emission trends for 1990-2000.

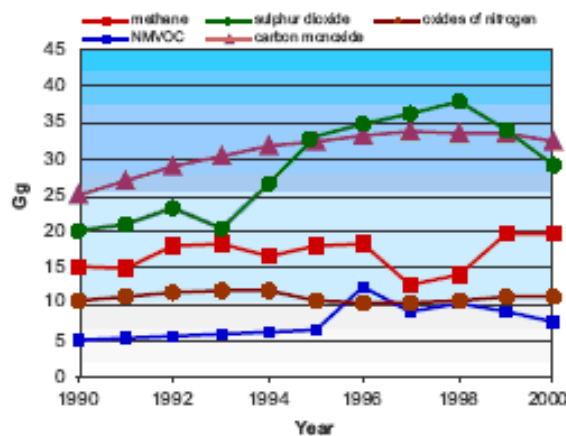
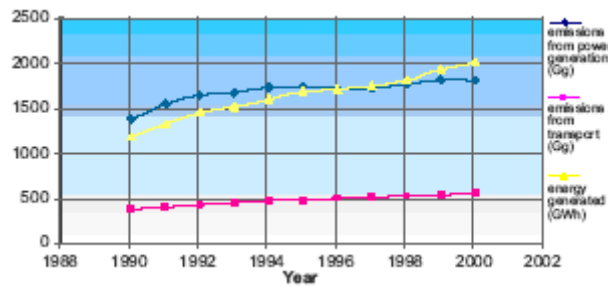

Figure 22: GHG emission trends for different gases 1990-2000.



**Figure 23: CO<sub>2</sub> emissions from electrical power generation, transport and energy generated.**

The 2004 specific emission from grid generated was calculated. A total of 2,277GWh were produced by Enemalta generating a total of 2,021,247 tonnes of CO<sub>2</sub>, these being the figure of both Delimara and Marsa Power Station. This leads to an average specific emission of 0.8767kg/kWh of CO<sub>2</sub> per kWh generated. This compares quite well with that stated by the “Malta UN convention on climate change”, a figure of 0.88 kg of CO<sub>2</sub> per kWh. This is higher than most of the smaller EU countries (e.g. Portugal 0.76, Denmark 0.82, and Ireland 0.81), due to lower generation efficiency and fuel used. Countries such as Luxembourg (0.98) and Greece (0.92) have higher specific emissions, possibly because of significant use of coal and biomass. Specific emissions depend on plant operating conditions and calorific value of the fuel.

This 0.88767 kilograms of CO<sub>2</sub> per kWh generated also shows the percentage reduction of CO<sub>2</sub> emissions when compared to the 1990 average CO<sub>2</sub> rate production. In 1990, a total of 1279 GWh were produced by Enemalta generating a total of 1,400,000 tonnes of CO<sub>2</sub>, these being the figure of both Delimara and Marsa Power Station leading to an average specific emission of 1.09 kilograms of CO<sub>2</sub> per kWh generated. Thus the switchover from coal to heavy fuel oil resulted in an 18% reduction of CO<sub>2</sub> per kWh.

### 3.4. Wind Conditions in Malta.

The central position of the Maltese landmass is approximately 1,840 km east of the Straits of Gibraltar and about 1,520 km northeast of the Suez Canal. Malta is 93 km south of Sicily and 290 km north of the African Continent. The distribution of the European and North African land masses exerts a considerable influence on the strength, directions and times of occurrence of winds in Malta.

In order to assess the suitability of wind energy production, both wind speeds and direction had to be analysed. Though there are some institutions in Malta who are currently monitoring these on an hourly basis, it was impossible to get hold of this actual data. Thus a different approach was taken

in order to obtain the corresponding data. METEONORM 5.0 (Edition 2003), a simulation program which is based on over 18 years of experience in the development of meteorological databases for energy applications was used. It is a comprehensive meteorological reference, incorporating a catalogue of meteorological data and calculation procedures for solar applications and system design at any desired location in the world. From the monthly values (station data, interpolated data or imported data), METEONORM calculates hourly values of all parameters using a stochastic model. The resulting time series correspond to "typical years" used for system design. Together with the wind speed and wind direction, the global and diffuse radiation both on a horizontal and tilted plane were also derived. The data was cross checked with available reports, authorities and wind atlases in order to verify the data authenticity.

### 3.4.1. Analysis of the obtained simulated Wind data.

Since Meteonorm, the program used for simulating wind data is capable of providing 8760 hours of wind speeds and directions, the simulated could be better be analysed. At this stage, Homer Simulating software was also used in order to analyse the data graphically.

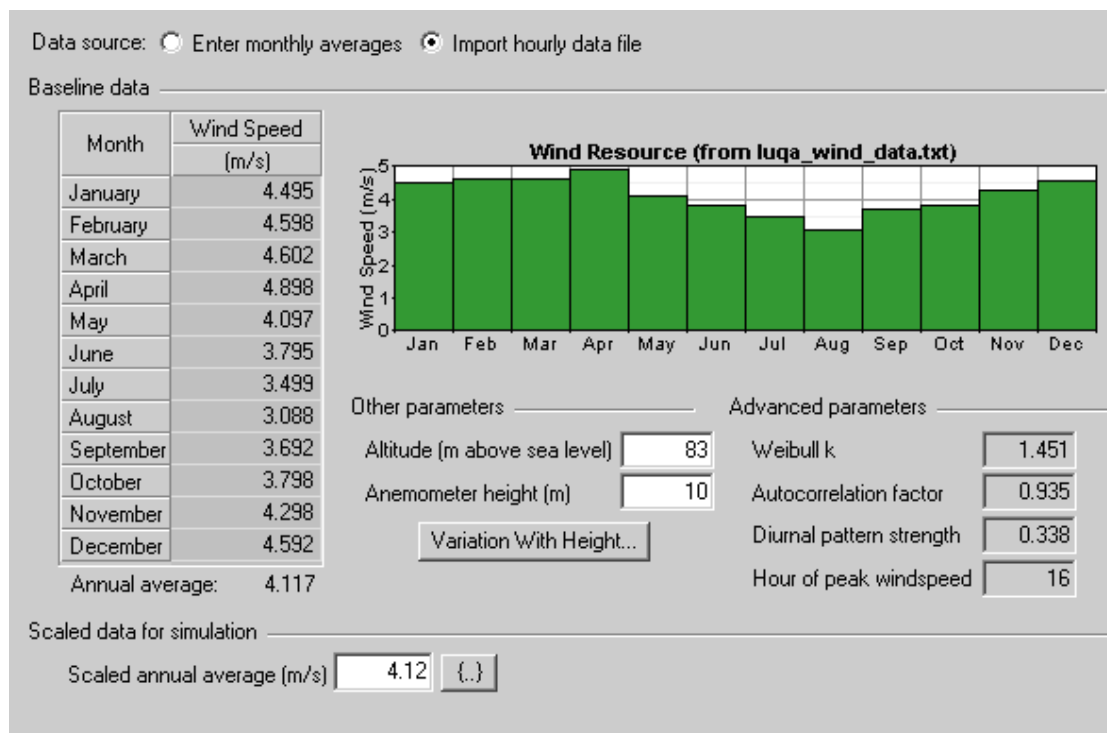

Figure 24: Simulated wind resource data

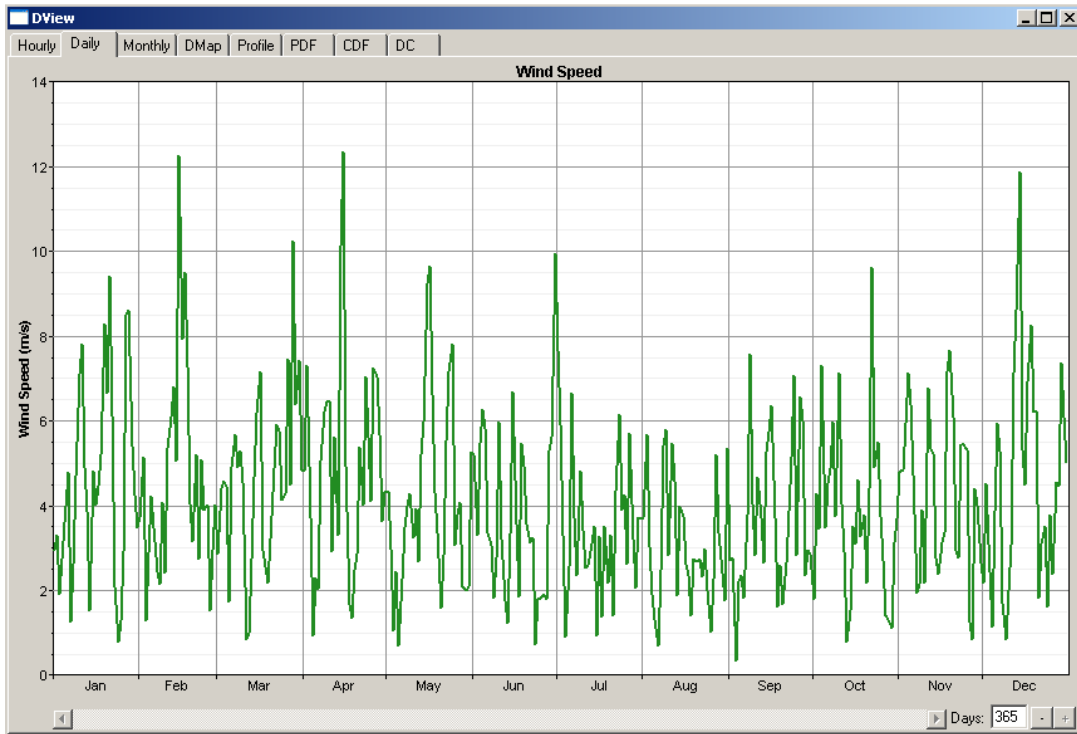

Figure 25: Daily wind speed variation for the whole year.

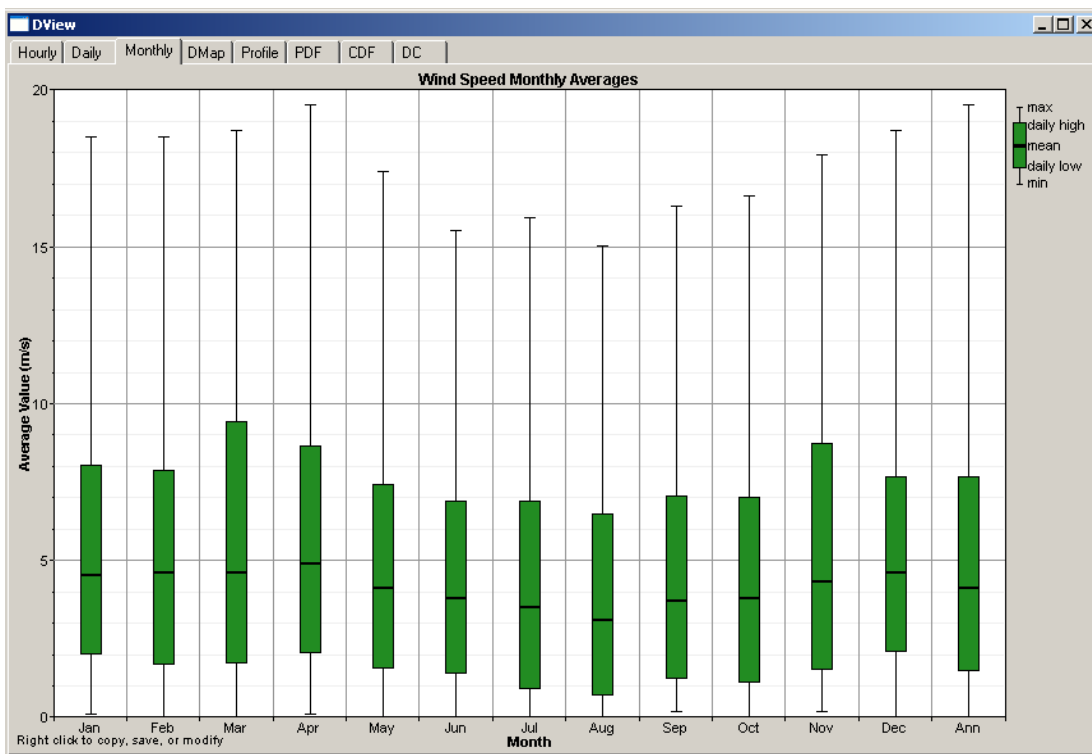

Figure 26: Wind speed monthly averages.



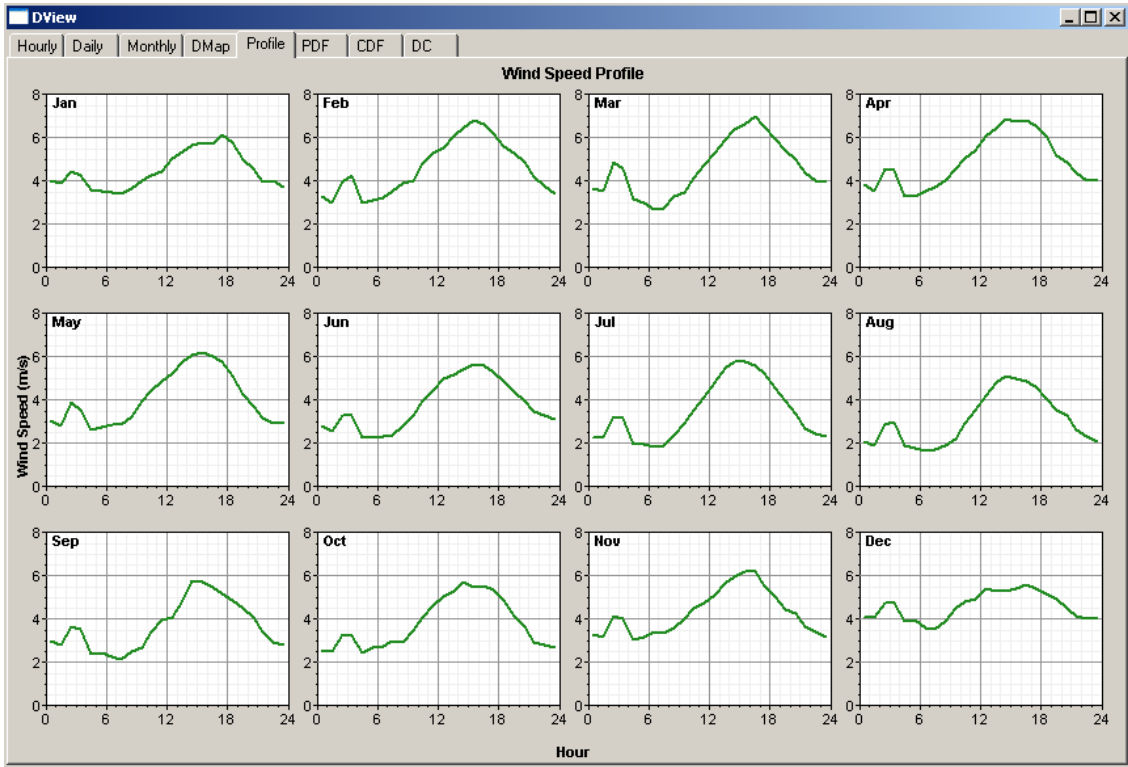

Figure 27: Monthly wind speed profile.

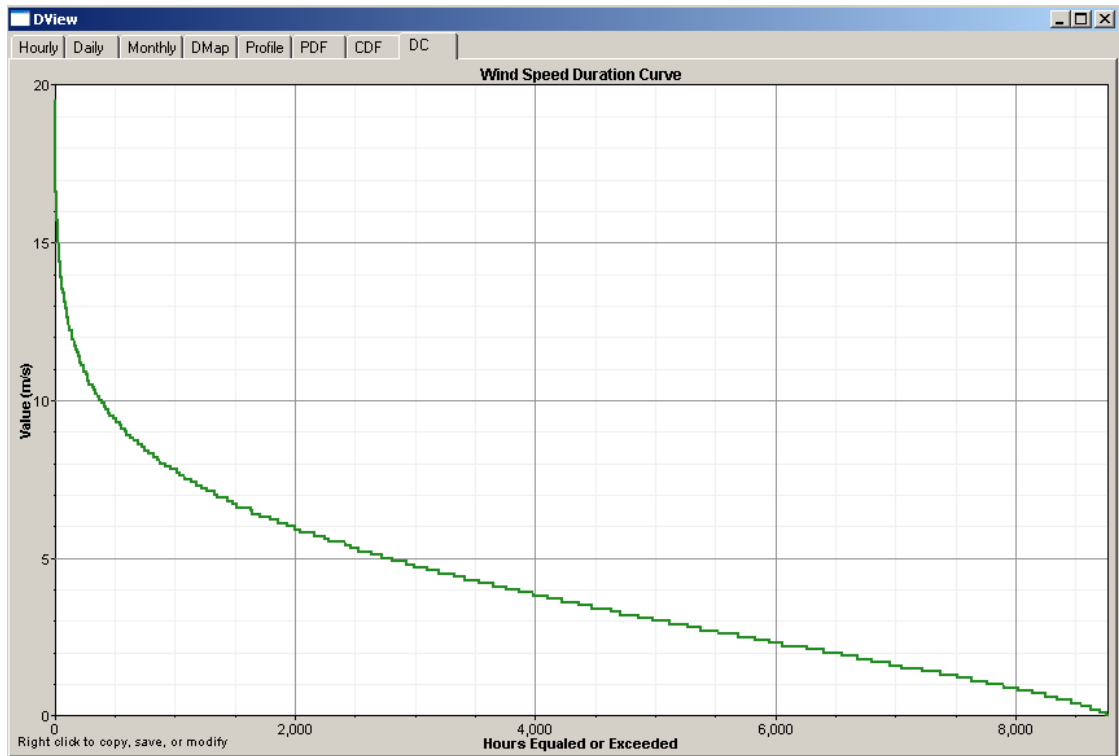

Figure 28: Wind speed duration curve.

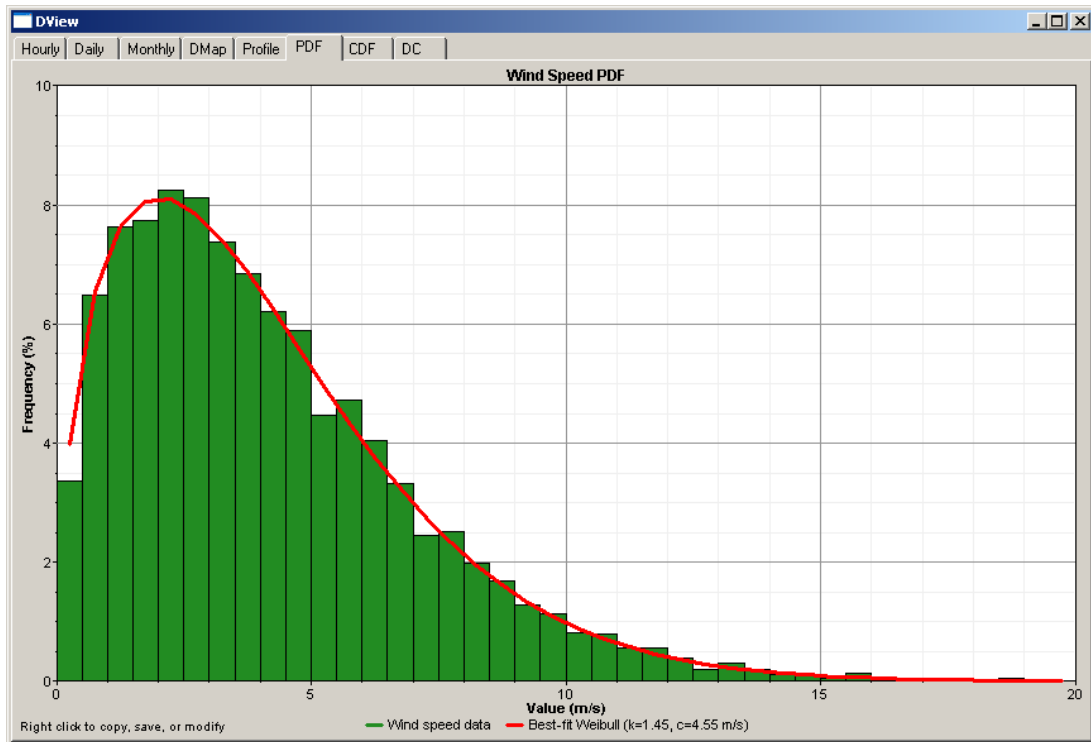

Figure 29: Wind speed distribution function

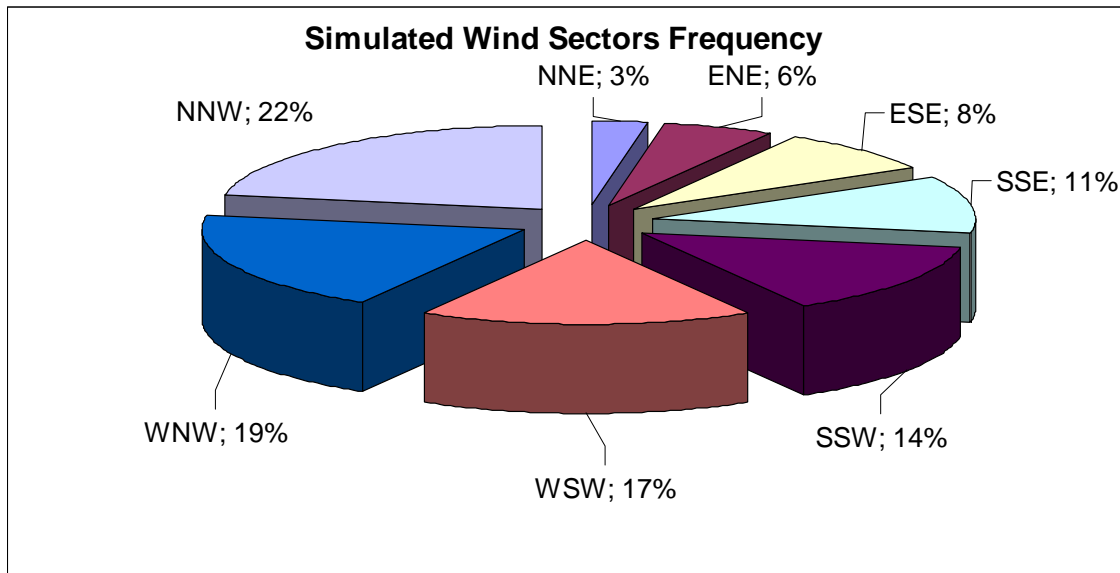

Figure 30: Frequency of the simulated wind directions.

The extent and quality of data sets obtained was reviewed and is presented in the above figures. The above figures depict that there is a drop in the summer winds as stated earlier. The simulated prevailing winds seem to agree with the wind rose in Figure 33 and previous presented figures. Thus it could be concluded that the simulations are quite realistic ones. Further more it could be

seen that the average wind speed obtained from simulation is 4.12m/s whilst that obtained from the Malta weather services is 4.46 m/s. This implies a variation of about +/- 8 % between the simulated and the obtained results. This compares very well with the average wind speed obtained in Figure 31. Though in this study offshore wind farms will not be investigated, this shows that the wind speeds around Malta are encouraging. This was further investigated by Mr. Joe Meilak in his paper “A case for Maltese Offshore wind farm: challenges and opportunities” 2004.

### 3.4.2. Evaluation of wind data at Luqa

After analysing the simulated results, these were compared. It was concluded that the predominant wind is the NW wind (Majjistral) which is due to the strong heating of the Sahara desert where the ascending hot air has to be replaced by the inflow of air masses from Europe. Its direction is nearly parallel to the geographical orientation of the Maltese Islands which also extend chiefly from NW to SE. This wind direction will be a factor in determining the best place to locate wind turbines. Another strong but less frequent is the wind blowing from the North East. The common occurring spring and summer wind blows from the Sahara. It is quite a hot wind usually carrying sand. Finally, in fall, there occurs a south west wind. It is a relative cool and moisture-laden wind, generally causing rain.

**Table 16: Typical surface roughness exponents.**

Surface type	Surface Roughness exponent ( $\alpha$ )
<b>Smooth</b>	
Ice	0.08
Mud/ Snow	0.11
Sea	0.12
<b>Moderately rough</b>	
Short grass	0.13
Crops	0.14
<b>Rough</b>	
Rural	0.20
Woods	0.23
<b>Very Rough</b>	
Suburban	0.25-0.4

The Maltese islands are relatively small and flat and therefore do not affect these large area winds in respect of either the direction or the wind velocity profile at various altitudes. The surface

roughness is a factor that however should be considered. Typical surface roughness exponents are suggested in Table 16 . In the present study, and according to experience gained an  $\alpha = 0.15$  was used to represent a general roughness for onshore sites on the island. This is obviously expected to be better for offshore sites, thus a worst case scenario is being considered. More discussion on the appropriate choice of the power law exponent,  $\alpha$  can be found in [61].

#### **3.4.2.1. Effect of topography on the wind velocity and direction.**

The geographical location of the Luqa metrological station is at latitude  $35^{\circ} 51.5'$  North and longitude  $14^{\circ} 28.5'$  East. The recording instruments are at an elevation of 10m above ground level and 94m above mean sea level (MSL). The Luqa station is located 20km inland. Thus the validity of extrapolations obtained from the Luqa station has to be compensated depending on the topographic conditions in which the data will be used.

The prevalent wind direction as established in Figure 30 occurs in the NW sector. Due to its geographic location of the meteorological station, a certain attenuation results in this NW wind. The same is true of winds from the WNW because of the shielding of the high plateau and of the steep coastal escarpment. It may therefore be assumed that in the unsheltered coastal locations in the North West quadrant are in fact higher than those recorded at Luqa. This is also true because at this quadrant of the island, the height above mean sea level is higher than that at Luqa. As far as the southern part of Malta is concerned, on the adversary, the wind velocities from the directions S to SE measured at Luqa are probably representative of the actual conditions because of the less influencing topographical effects. The same can be said to easterly winds because the cover up effect of the built up areas are cancelled out by the fact that the meteorological station is at a higher elevation.

The swerving of the prevailing wind as an effect of the deflecting steep coastal escarpment should not be very important because the prevailing NW wind direction is very nearly parallel to this protective embankment. Only westerly to southerly winds are likely to suffer a light veering due to the coastal orientation of this part of the island. Winds from other directions pass over a gently climbing tract with little or no effect at all.

#### **3.4.3. Analysis of results from previous authorities' measurements**

Different studies were concerned in the determination of average wind speeds and wind speed variations across the Maltese islands. An ongoing monitor of the wind data is performed by Malta

weather services. Other monitoring authorities include the Malta Metrological Authority at the Malta International Airport and the Institute for Energy technology at the University of Malta. Only Malta weather services provided us with the necessary data.

Table 17 indicates the average actual mean monthly wind data for Luqa Airport obtained from Malta weather services in m/s at 10 m height at Luqa. The overall average for the 33 years was calculated to be 4.46m/s. Though at a first glance this wind speed seems not to be so promising, one has to note that this average drops due to the summer months mean which greatly influence the overall average. This average wind speed is a function of height. Thus one would expect higher wind speeds at higher altitudes. This wind speed variation will be simulated.

**Table 17: Average monthly wind speed for different yearly periods [62]**

	Jan	Feb	Mar	Apr	May	Jun	Jul	Aug	Sept	Oct	Nov	Dec	Avg.
<b>1961-1970</b>	5.30	5.35	5.40	5.35	4.73	4.17	3.40	3.40	3.50	3.55	4.32	5.40	<b><u>4.50</u></b>
<b>1971-1980</b>	4.99	5.56	5.40	5.66	4.73	4.58	3.96	3.81	3.96	4.27	4.73	4.89	<b><u>4.71</u></b>
<b>1981-1990</b>	5.35	5.04	4.99	4.89	4.53	3.96	3.50	3.50	3.60	3.66	4.53	4.73	<b><u>4.36</u></b>
<b>1991-1994</b>	4.32	5.14	4.78	5.14	4.27	4.37	3.50	3.04	3.45	4.32	4.01	4.58	<b><u>4.26</u></b>
<b>1961-1994</b>	<b>33 years overall average in m/s</b>												<b><u>4.46</u></b>

Some studies are worth mentioning in order to figure out a better picture of the wind situation in Malta. The first is the wind atlas of the world map as presented by the Wind Energy Department at Risø National Laboratory in Roskilde, Denmark. This presents the wind resources over open sea for five standard heights. It could be clearly seen that Malta lies in the 4.5-6 m/s area for the 10 m height altitude. The available wind map (Figure 31) shows that, owing to the unsheltered location of Malta in the Mediterranean, the mean yearly wind velocities are likely to be higher than those in Central Europe.

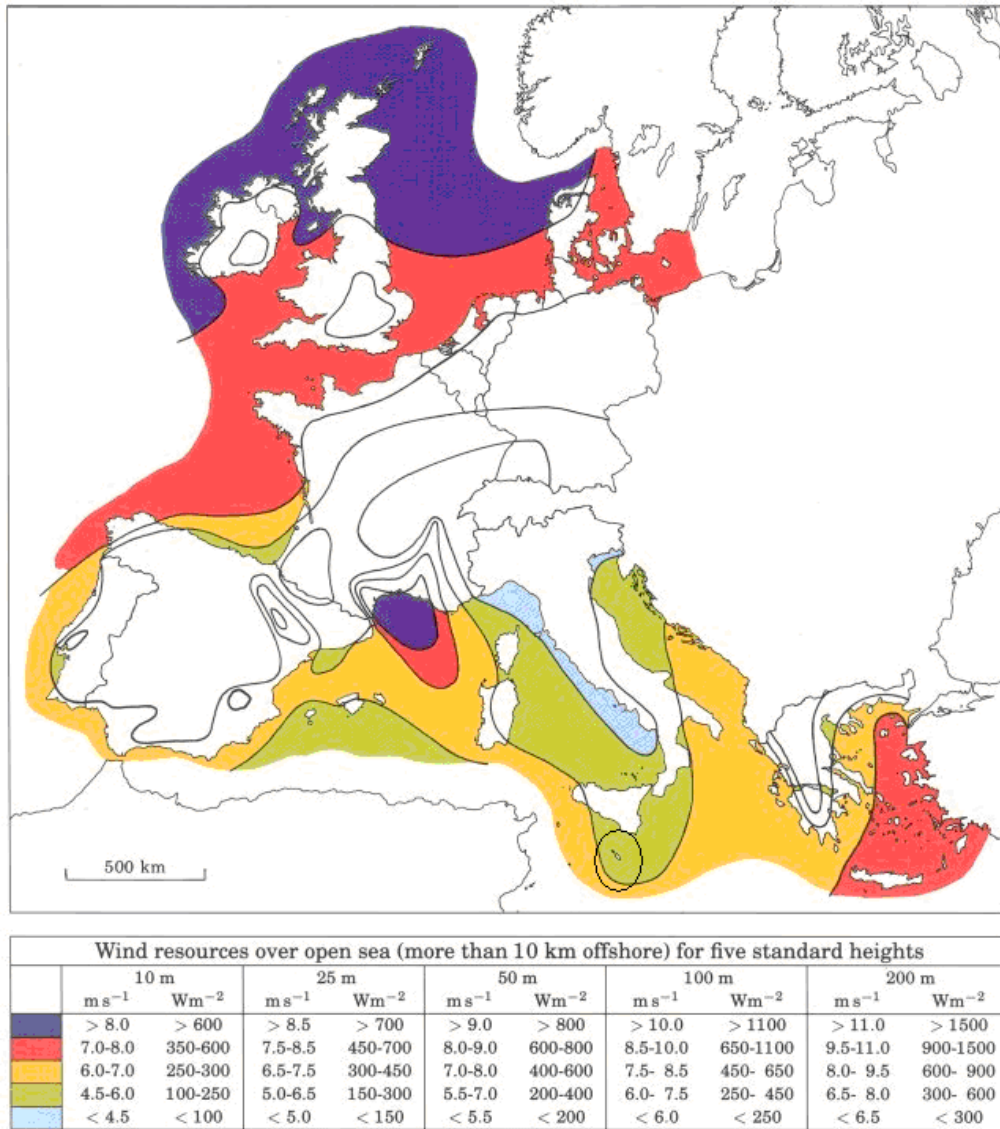

Figure 31: European wind resources over open sea [63].

Another study is a Report prepared by Scott and Wilson for Malta Maritime authority. In this Report: “Malta Significant Wave height study”, the offshore and onshore wind roses are presented. The NW and WNW prevailing wind direction could be easily seen. The average wind speeds according to the wind direction is also possible to configure. Figure 32 and Figure 33 show wind roses derived from the MIA data for the annual and summer periods of operation respectively. As would be expected, these wind roses show a dominance of north-westerly winds for both periods of operation. When these are compared it can be seen that the directional distribution of wind is similar for the annual and summer periods of operation.

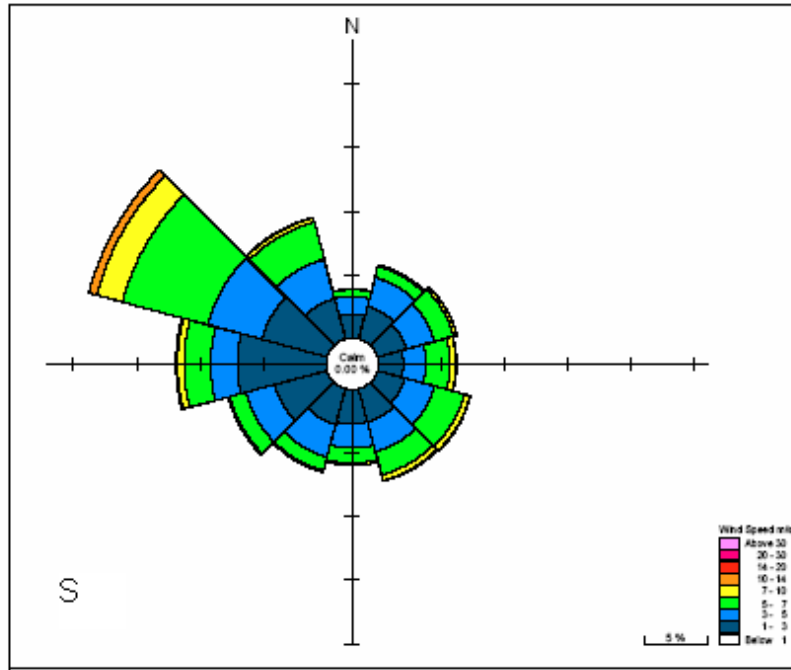

Figure 32: Wind rose at Malta International Airport for the summer period of operation [64]

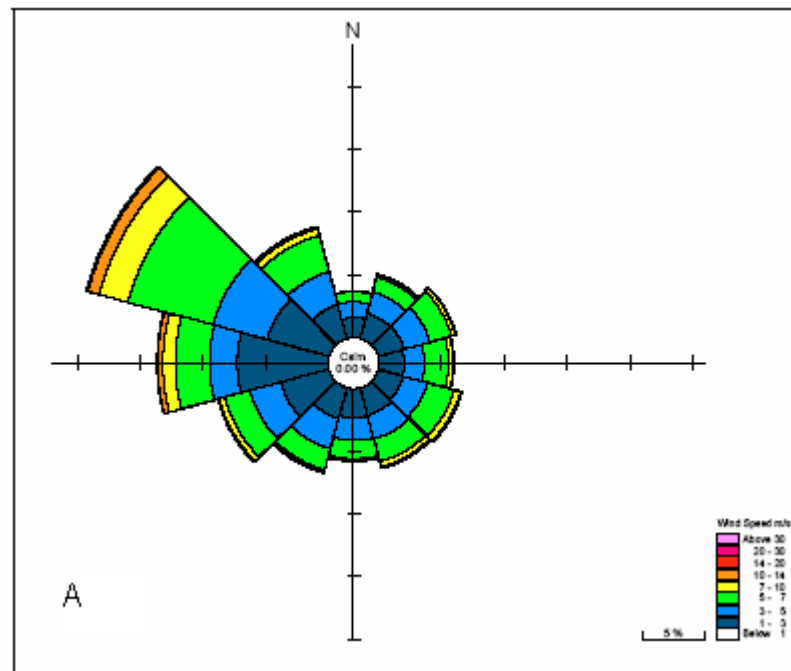
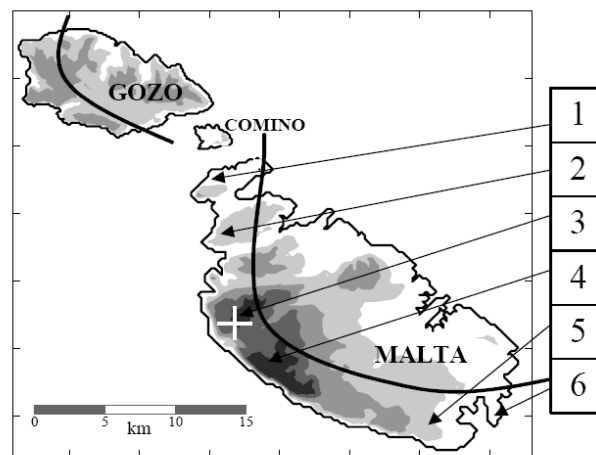

Figure 33: Wind rose at Malta International Airport for the annual period of operation [64]

### 3.4.4. Ideal Sites and availability of sites

The selection of best possible sites is based on the optimal wind direction and magnitude together with the height of the prospective area. After analysing the contour heights and the prevailing wind direction, it was concluded that the best onshore locations would be as shown in Figure 34. The vicinity of Dingli cliffs (numbered as 4 in Figure 34) being the most favourable at an altitude of 200 to 250 m above mean sea level (MSL). This area is a higher mean altitude than other prospective areas in Malta. Further more it is immediately adjacent to the coastal escarpment which exerts a considerable effect on winds that are blowing from the NW quadrant. Following this area, the prospective site would be the edge of the Victoria lines at an altitude of 175 to 225 m above MSL and Wardija Ridge at an average elevation of 135m above MSL numbered as 3. Other western potential places on the island of Malta are 1- Marfa ridge, 2 - Mellieħa ridge, 5 - Hal far area and 6 - Delimara. Finally the potential of installing Wind energy converters on the Magħtab Landfill has also been proposed due to its space availability and altitude. The geographic position of this site is not the most ideal for the prevailing NW wind however it is known that some wind speed analyses are going on at top of Magħtab Dump. A permit for the temporary installation of a wind monitoring mast (18-24months) was requested from the Malta Environment and Planning authority (MEPA) in 2004 [65]. Thus the adequacy of this site should be further investigated.



Source: The Renewable Energy Potential of the Maltese Islands  
Farrugia R.N., Fsadni M., Mallia E.A., Yousif C.

**Figure 34: Onshore wind potential sites.**

Other elevated sites are also present in Malta such as Marfa ridge. However from previous studies it has been concluded that these sites are unsuitable for wind conversion sites due to turbulence induced by the cliffs. Other potential sites are also available in Gozo and offshore. Other offshore



sites have been proposed [66] namely Sikka l-Bajda, Ras il-Griebeg, Il-Ponta tal-Qawra, Ghallis Rocks, Marku Shoal, Madliena Shoals, St. George's Shoals, Sikka l-Munxar, Benghajsa Patch, Hamrija Bank which are all within the 20 metres depth. Another possible site is Hurd Bank, however this lies at a depth of 30 metres.

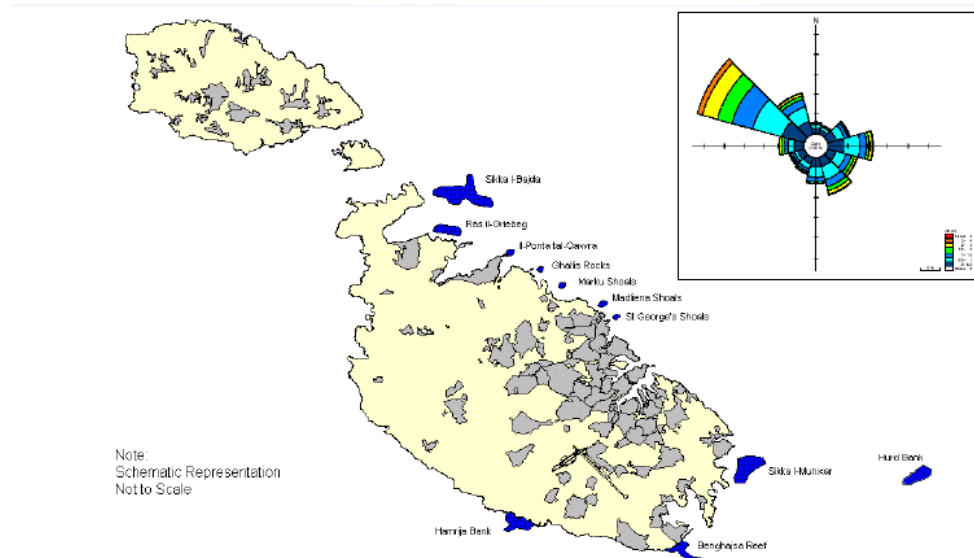

**Figure 35: Shallow (<20m) offshore sites suitable for wind energy production [66]**

Though many sites have been suggested, the practicality and use of these sites has to be investigated. All sites are ‘reefs’, with characteristics that make them highly important for ecological and maritime activity (bunkering, diving, fishing and marine ecology). According to the Malta Tourism Authority (MTA) all sites are considered unsuitable from the point of view of tourism, considered as assets, which are important amongst others for the diving industry: “Reefs are major tourist assets. They attract fish life and are of significant actual or potential importance for the diving industry” [66]. The MTA is therefore against any damage to such features and would therefore strongly advise against the use of reefs for wind farm development.” Other authorities, particularly Malta Maritime Authority (MMA) and Malta International Airport (MIA) may in a particular not support the construction of the wind turbines due to the importance of these sites for their operation. MMA sees these sites as of particular importance for the bunkering business whilst MIA sees these turbines as an obstacle to the heavy airplane traffic and communication interference. Thus unless a consensus is found between all concerned parties the technology has either to be installed in deeper waters (still an immature technology) which is more possible around the Maltese coast or else has to be abandoned.

### 3.5. Solar Conditions in Malta

#### 3.5.1. Analysis of the obtained simulated Solar data.

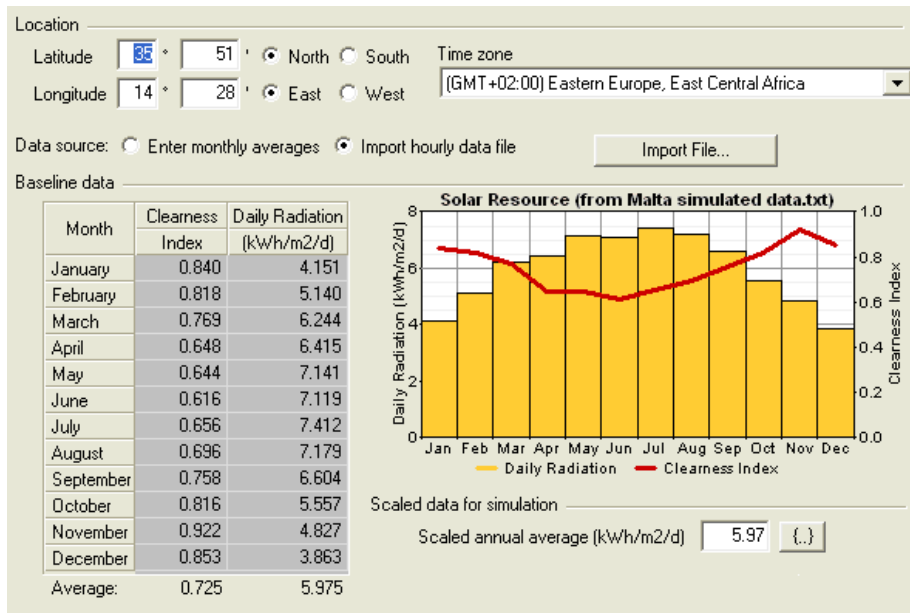

Figure 36: Simulated data for solar radiation

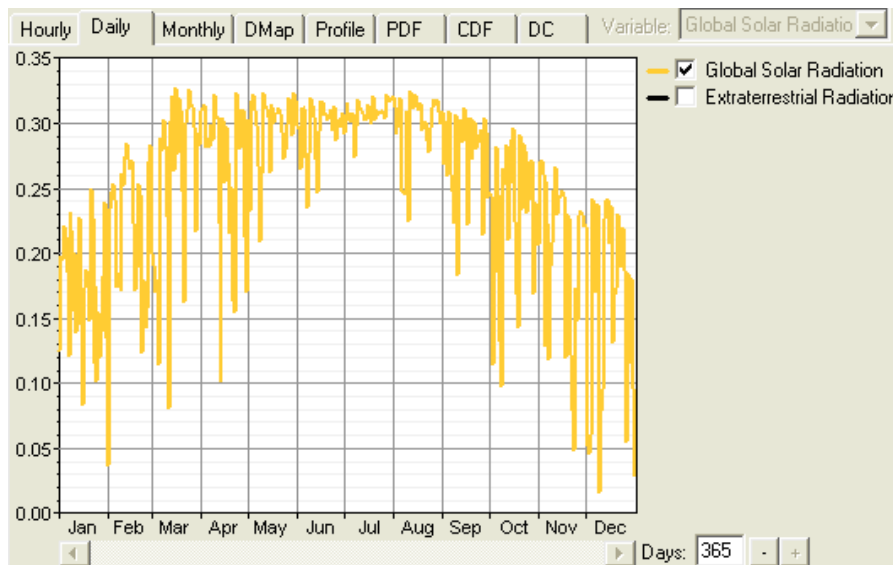

Figure 37: Daily global solar radiation

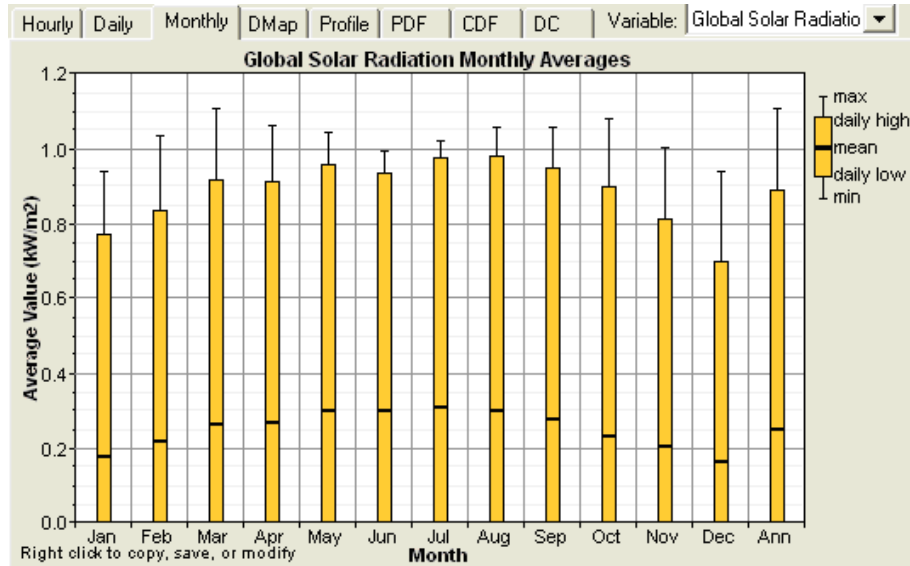

Figure 38: Monthly averages

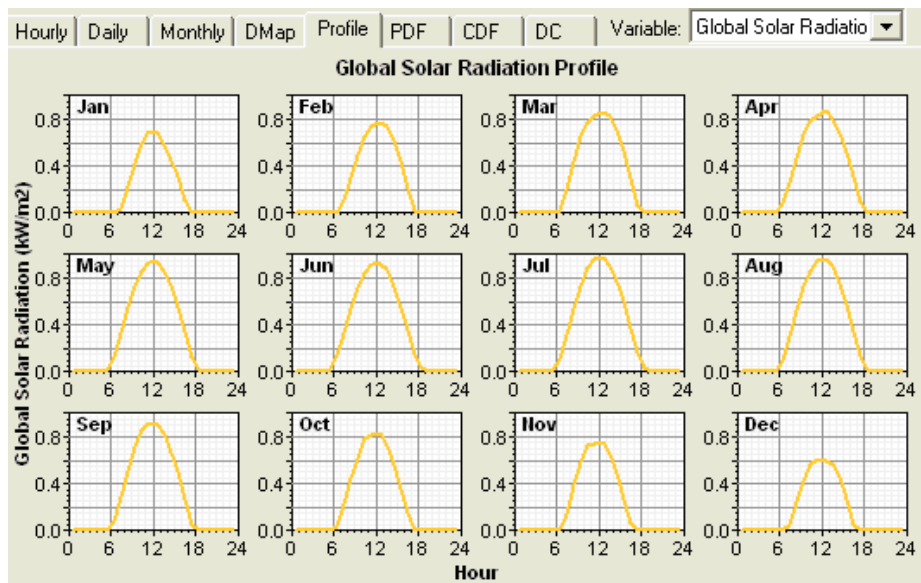
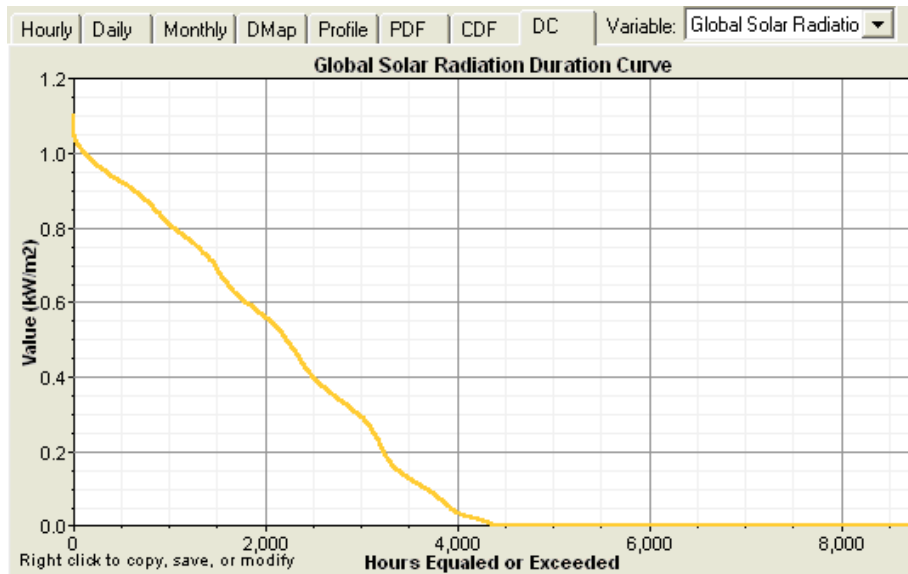

Figure 39: Monthly global solar radiation



**Figure 40: Solar duration curve**

Homer simulating software was also used in order to analyse the data graphically obtained once again from Meteororm simulating software. The data obtained was reviewed and is presented in the above figures. These depict that, as expected, there is an increase in solar radiation from January till July and then an eventual decrease till December. July according to the simulated data stands at  $7.412 \text{ kWh/m}^2/\text{d}$  as shown in Figure 36 with December standing at  $3.863 \text{ kWh/m}^2/\text{d}$ . The simulated monthly average is  $5.975 \text{ kWh/m}^2/\text{d}$  with an average clearness index of 0.725 as shown in Figure 36. Individual monthly results are also presented (Figure 39). The other figures presented show more specific monthly values with Figure 40 providing the numbers of hours a specific  $\text{kWh/m}^2$  reached. The obtained results compare very fine with other results obtained from other authorities earlier presented. For example, Figure 44 leads to a yearly average of  $5423 \text{ Wh/m}^2/\text{day}$  whilst that Meteororm simulated data leads provides  $5.97 \text{ kWh/m}^2/\text{day}$ . This is quite an acceptable difference. Whilst that both results as well show that July is the best month for solar energy production, discrepancies lie how much could be produced. Whilst that Figure 44 shows that the maximum is  $8.4 \text{ kWh/m}^2/\text{d}$ , Figure 36 places this peak at  $7.412 \text{ kWh/m}^2/\text{d}$ , a difference of about  $\pm 10\%$ , which would need further investigation from actual measured results over a longer period if this needs to be accurately analysed. This percentage difference is once again quite similar to that found out in the wind section of  $\pm 8\%$ . The yearly horizontal surface radiation simulated data stands at  $2180.731 \text{ kWh/m}^2$  which is a little bit more than that shown in Figure 41. However, for the purpose of the study, the simulated data is within acceptable difference. The optimal inclination angle is not based on any probability thus there is no difference between the simulated and the calculated one. The

best angle for the island of Malta lies at 32 degrees according to the simulated data (Figure 46). Steeper angles such as 35 degrees still yield to good performance.

### 3.5.1.1. Analysis of results from other studies and authorities.

The solar potential for the Maltese islands is surely a point of no discussion. Various European authorities involved in this sector use Malta to benchmark the potential of other countries. For example a renewable information website in the UK states that “European researchers have published an online practice map that shows how well solar power can work. Then compare your location to a location in Spain, Malta or Germany...” [67]. Similarly, [68] states that “The results reveal significant regional differences, determined by latitude, continentality, terrain and local climatic variations. It is obvious that the highest energy potential is in the Mediterranean regions with a lot of sunshine in summer (Malta, Cyprus, Portugal, Spain, Greece, Italy and Southern France).” Malta places first in Europe in terms of the availability of solar energy with the least annual variations, as shown in Figure 41 (Yearly sum of the electricity generated by a typical 1 kWp PV system in the built-up areas of the EU25 Member States [kWh.year-1].[68]) and specifically described in Table 18 . The PV-generation potential in fact has been estimated to be around 1500 kWh/annum which averages much better its competitors in Europe typically 800 kWh/annum.

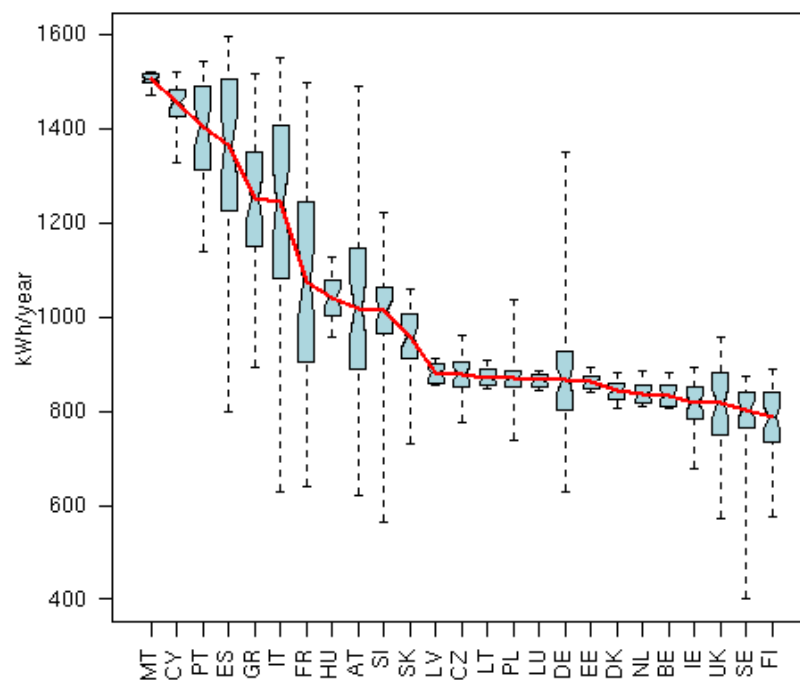

Figure 41: Yearly sum of the electricity generated by a 1 kWp PV.

**Table 18: Description of the clearness index of the sky over Malta [68]**

<b>Sky Description</b>	<b>Range</b>	<b>Occurrence (%)</b>
<b>Cloudy</b>	$G/H_0 < 0.2$	2.9
<b>Partly Cloudy</b>	$0.2 < G/H_0 < 0.6$	34.5
<b>Clear</b>	$0.6 < G/H_0 < 0.75$	61.9
<b>Very Clear</b>	$G/H_0 > 0.75$	0.7
<i>Where <math>G</math> = Global Horizontal solar radiation, <math>H_0</math> = Extraterrestrial radiation and <math>G/H_0</math> = Clearness Index</i>		

Also, recently, the institute for environment and sustainability (IES) together with the European commission, Directorate-General, Joint Research centre have launched a web site aiming to provide more information about solar potential [70]. One can find web applications to browse and query GIS databases of solar radiation and other climatic parameters. The data make it possible to estimate PV electricity generation at any location in two regions:

- Europe
- Africa, Mediterranean Basin and South-West Asia

The available obtainable data vary from solar irradiation and irradiance data which provides monthly and yearly averages of global irradiation at horizontal and inclined surfaces, as well as other climatic and PV-related data. The site also provides solar electricity production. This application calculates the monthly and yearly potential electricity generation  $E$  [kWh] of a PV configuration with defined modules inclination and orientation using a formula:

Equation 11: 
$$E = 365P_k r_p H_{h,I}$$

Where  $P_k$  (kW) is the peak power installed,  $r_p$  is the system performance ratio (typical value for roof mounted system with modules from mono- or polycrystalline silicon is 0.75) and  $H_{h,I}$  is the monthly or yearly average of daily global irradiation on the horizontal or inclined surface. The calculator can suggest the optimum inclination/orientation of the PV modules to harvest maximum electricity within a year. Figure 41 and Figure 42 presented by [46] show a colour reference diagram, mainly for European and North African countries, for the yearly sum of global irradiation incident on an optimally inclined south oriented photovoltaic modules (upper scale of Figure 42) and the yearly sum of solar electricity generated by a 1kWp system with optimally inclined modules and performance ratio 0.75 (bottom scale of Figure 42).

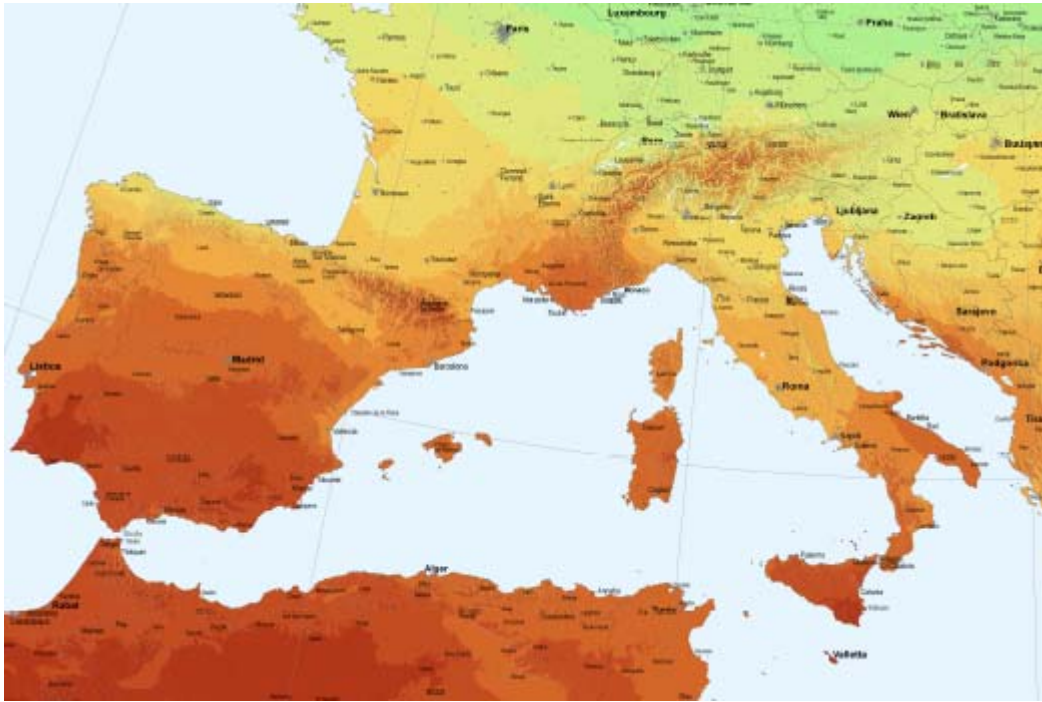

Figure 42: Photovoltaic solar potential in some of the European countries [70].



Figure 43: A colour reference diagram.

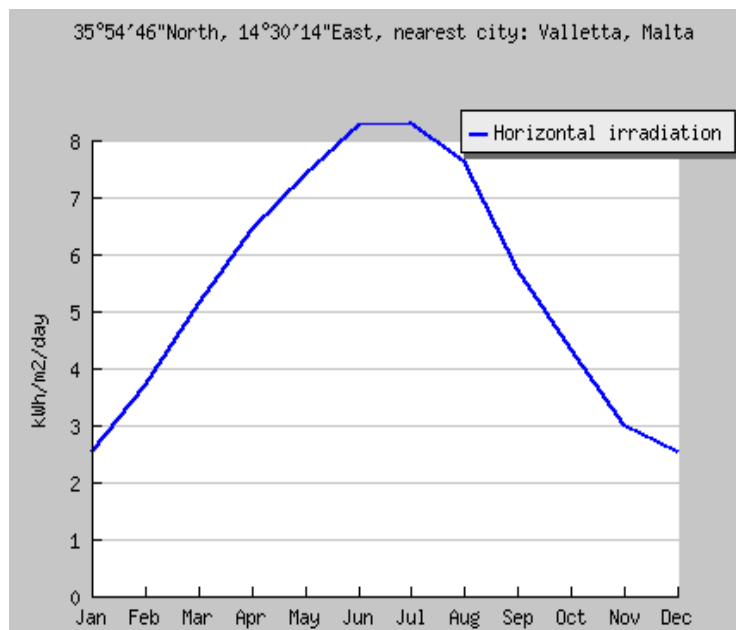

Figure 44: Output from panel for horizontal irradiation; yearly average of 5423 Wh/m<sup>2</sup>/day.

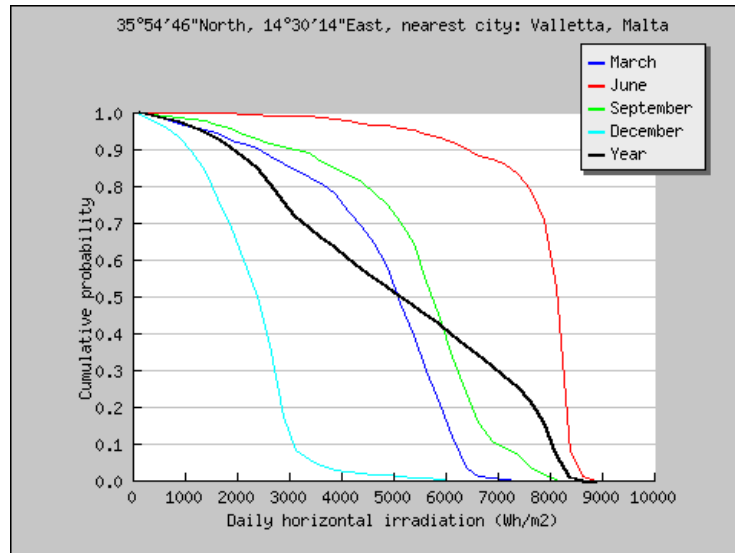

Figure 45: Probability versus daily horizontal irradiation for different months.

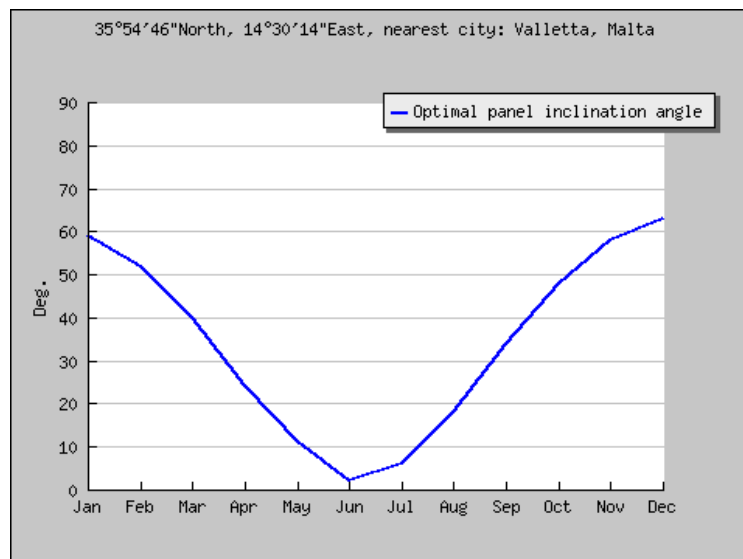

Figure 46: Optimal monthly inclination leading to a 32 degrees yearly optimal.

### 3.5.2. Evaluation of the solar data.

There are several things to consider when evaluating a site’s solar potential. Amongst these lie an area large enough for installation and the solar radiation received. Approximately a 10 sq ft area is enough to produce between 100 and 150 watt hours per hour at peak sun. The tilt and azimuth angle (Figure 47) is also an important issue when it comes to optimise the output of a PV panel. This varies according to the location of the place. It is important to optimize the system performance by choosing the best orientation and minimizing the degradation due to shading. The desire for



optimum performance should be tempered with considerations of added costs, aesthetics of the installation, and ease of maintenance.

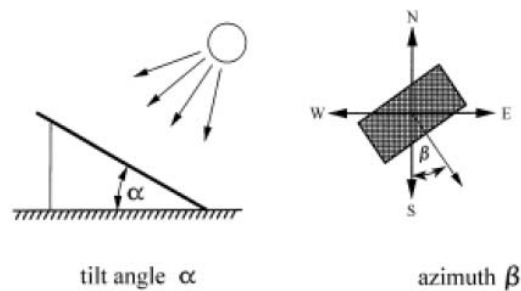

**Figure 47: Tilt and azimuth angle**

The optimum tilt angle ( $\alpha$ ) is usually determined by the nature of the application. Arrays which are to provide maximum generation over the year should be inclined at an angle equal to the latitude of the site. Stand-alone systems which are to operate during the winter months have arrays inclined at a steeper angle of latitude. If power is required mainly in summer, the inclination angle has to be less steep than the latitude angle. The azimuth angle ( $\beta$ ), is the angle between the true geographic South and the solar array.

Solar radiation measurements are of great importance in the field of renewable energy application and climatology. They provide solar energy availability at ground, which, for example, is the basic information for the installation of photovoltaic systems. Actual data is usual hard to get and not available off the shelf. Meteonorm software was once again used to simulate the necessary data. This, same as for wind energy, is capable of providing 8760 hours of solar data for the islands of Malta. From the monthly values (station data, interpolated data or imported data), the software calculates hourly values of all parameters using a stochastic model that gives insolation values which represent the resource available to a flat plate collector oriented due south at an angle from horizontal equal to the latitude of the collector location. The resulting time series correspond to "typical years" used for system design. However, before proceeding with the simulations, it was necessary to evaluate this data and benchmarking it against other obtained or simulated data.

### **3.5.3. Ideal Sites and availability of sites.**

The topography of Malta was earlier described in section 3.4.2.1. Having the second greatest population density in the world, Malta has 16% of the surface area of mainland built up for housing and another 0.3% is put to industrial use. As a result, Malta has a population density of 9,015

persons per km<sup>2</sup> in built-up areas [28]. The main potential categories for PV installation are mainly buildings rooftops varying from domestic rooftops, industrial estates and public buildings. The available area on the Maltese islands for PV installation has been already investigated in a conservative way by [71]. Based on his study, the major potential lies in the domestic sector and reaching up to 165,000 MWh per year or about 7.5% of the total electricity generated in 2003. This is followed by the industrial estates that form 1.5% and finally the public buildings including hotels, schools, hospitals, etc, which would be capable of producing 0.15%, thus bringing the total potential to 9.1%. All these figures are calculated assuming an area of 7m<sup>2</sup> of PV for 1.2 kWp. This leads to an approximate area of 5m<sup>2</sup> per kWp of PV. A set of conservative conditions were considered in this case varying from reduced efficiency to reduced available space. A similar study by the same author claims in [72] that “the total amount of flat roof area, that is suitable to place the PV modules is at least 10,000,000 m<sup>2</sup>”. Considering the solar potential in Malta these figures are surely encouraging.

### **3.6. Hydrogen Energy Potential in Malta**

“In Malta water is as precious as it is scarce, because of geographic and climatic conditions. The Maltese islands have no surface waters on which to rely, but depend instead on frail groundwater that is nowadays subject to intense pressures by different sectors of the community. Malta is among the first 10 top-ranking countries in global water scarcity with the highest competition index ...(Margat and Vallee, 2000).”[73]

In view of the above, the production of hydrogen from rain water will surely find some objections. On the other hand, abundant sea water supply exists around Malta. Unfortunately by placing two conventional electrodes in seawater and applying a voltage source across the electrodes does not produce hydrogen. In fact, electrolysis of seawater will produce chlorine, hypochlorite and chlorate. It has been demonstrated however, that manganese dioxide coated electrodes are capable of producing oxygen with 99% efficiency. Therefore the direct electrolysis of seawater in this way to produce hydrogen and oxygen is possible and advantageous [74]. About 1 litre of water is required to produce 1 Nm<sup>3</sup> or 0.09 kg hydrogen.

#### **3.6.1. Status of the technology in Malta.**

Hydrogen in Malta is still in an immature state and has not yet gained significant importance and consideration. Considering that internationally hydrogen technology is still under evolvment, it is illogical to consider that such a technology is already flourishing in Malta. Hydrogen has been

considered in [46] and [53] and some studies have been effected by Dr. Ing. Richard Blundell: “Considerations in introducing hydrogen technology and economy in small, densely populated, island states, without indigenous energy sources. The case of Malta”. However, being an island with a lot of renewable potential, Malta has the potential of being an experimental place of joining such potential with hydrogen production and utilisation. In fact, some recent presentations tackled this.

### 3.7. RenewIslands Methodology applied to Malta

#### 3.7.1. Mapping the needs

Malta is a small island, however with a high density population. The main economic activity is tourism, with a great seasonal variation. Due to its hot climate, cooling needs especially during the summer periods needs are very high. On the other hand, heating is considered as a low necessity mainly needed during peak winter times. Transport is responsible for an important high share of energy consumption, 20% [53] out of which 65% is used for road transport, the rest for aviation; however those are short range displacements [55].

Electricity is a highly demanded commodity, mainly concentrated in industrialized areas, both touristic and manufacturing. Water needs are mainly for housing, industry and service sector (especially tourism related) as water used for agriculture is mainly dependent on captured rainfall. Waste and wastewater treatment though these are dispersed all over the island, may be considered as concentrated due to the collection infrastructure.

**Table 19: Mapping Malta community needs**

<b>Needs</b>	<b>Level</b>	<b>Geographic Distribution</b>	<b>Code</b>
<b>Electricity</b>	Low, Medium or High	Dispersed, Concentrated	ElectHC
<b>Heat</b>	Low, Medium or High	Dispersed, Concentrated	HeatLC
<b>Cold</b>	Low, Medium or High	Dispersed, Concentrated	ColdHC
<b>Transport fuel</b>	Low, Medium or High	Short, long Distance	TranHS
<b>Water</b>	Low, Medium or High	Dispersed, Concentrated	WaterHC
<b>Waste Treatment</b>	Low, Medium or High	Dispersed, Concentrated	WasteMC
<b>Wastewater treatment</b>	Low, Medium or High	Dispersed, Concentrated	WWTMC

### 3.7.2. Mapping the resources

The main renewable energy resources in Malta are Wind and Solar. The island is an isolated one with no grid or transport connections whatsoever as yet. Fossil fuel derivatives are shipped whilst that fresh water is obtained both from water tables and reverse osmosis of sea water, the latter being the main one. A hydrogen scenario can fit very well in Malta especially in the transport sector. This will be discussed further on.

**Table 20: Mapping Malta available resources**

Resource	Level	Code
<b>Local Primary Energy</b>		
Wind	Low, Medium or High	WindM
Solar	Low, Medium or High	SolarH
Hydro	Low, Medium or High	HydroL
Biomass	Low, Medium or High	BiomL
Geothermal	Low, Medium or High	GeothL
<b>Energy import Infrastructure</b>		
Grid Connection	None, Weak or Strong	GridN
Natural Gas Pipe Line	No, Yes	NGplN
LNG terminal	No, Yes	LNGtN
Oil terminal/refinery	No, Yes	OilRN
Oil derivatives terminal	No, Yes	OilDY
<b>Water</b>		
Precipitation	Low, Medium or High	H20PM
Ground water	Low, Medium or High	H20GL
Water Pipeline	No, Yes	AquaN
Sea Water	No, Yes	H20SY

**Table 21: Potential energy carriers (EC)**

<b>Energy Carriers</b>	<b>Condition</b>	<b>Potential EC</b>
Electricity	IF ElectC	ECEI
District Heating	IF HeatHC	-
District Cooling	IF ColdHC	ECDC
Hydrogen	IF Trans	ECH2
Natural Gas	IF (NGpLY OR LNGtY)	-
Biogas	IF (BiomH OR WasteHC OR WWT HC)	ECBG
Petrol / Diesel	IF (OilRY OR OilDY)	ECPD
Ethanol	IF (BiomH OR WasteHC)	ECEt
LPG	IF (OilRY OR OilDY)	ECLPG
Biodiesel	IF (BiomH AND WasteHC)	ECBD

Since there is no sort of connection to any mainland as yet, Malta has its oil derivatives storage in order to cater for its energy needs. Reversible-hydro potential is not a feasible solution due to low and distant heights above sea level. Since there are no significant altitude levels, the alternative is hydrogen storage. Excess wind can be electrolysed in order to produce Hydrogen. This is then stored and used in times of low wind or high energy demand unless not used for transport. Energy can also be recovered from waste where most of the waste is gathered in one central place. The landfill can be tapped in order to collect gas which can be used for the production of electricity generation.

**Table 22: Potential delivering technologies**

<b>Technology</b>	<b>Abbreviation</b>	<b>Condition</b>	<b>Code</b>
<b>Electricity conversion system</b>			
Wind energy conversion system	WECS	IF (ElectM OR ElectH) AND (WindM OR WindH)	WECS
PV solar electrical conversion system	SECS-PV	IF (ElectL OR ElectM) AND (SolarM OR SolarH)	PV
Solar Energy Conversion system	SECS-Thermal	IF (Elect) AND (SolarH)	SECS
Hydro energy conversion system	HECS	IF (Elect) AND (HydroM OR HydroH)	-
Geothermal energy conversion system	GECS	IF (ElectM OR ElectH) AND (GeothH)	-

Biomass energy conversion system	BECS	IF (ElectM OR ElectH) AND (BiomH)	-
Distributed energy generating system	DEGS	IF (Elect) AND (NGply OR LNGtY OR OilRY OR OiDY)	DEGS
Combined cycle gas turbine	CCGT	IF (ElectH) AND (NGply OR LNGtY OR OilRY OR OiDY)	CCGT
Fuel Cell	FC	IF (Elect) AND (H2Fuel)	FC
<b>Heating system</b>			
Solar Collector	STCo	IF (Heat) AND (SolarM OR SolarH)	STCo
Geothermal		IF (HeatH) AND (GeothM OR GeothH)	-
Heat Pump		IF (HeatH AND ECEl)	HPHe
Biomass boiler		IF (HeatH) AND (BiomM OR BiomH)	-
Gas Boiler		IF (Heat) AND (NGply OR LNGtY OR OilRY OR OiDY OR WasteG OR WWG)	GSSo
<b>Cooling system</b>			
Solar absorber		IF (Cold) AND (SolarH)	SABs
Heat Pump		IF (ColdH AND ECEl)	HPCo
Gas coolers		IF (ColdH) AND (NGply OR LNGtY OR OilRY OR OiDY OR WasG OR WWtG)	GSCo
Electricity coolers		IF (ColdH AND ECEl)	ELCo
<b>Fuel</b>			
Hydrogen		IF (Tran) AND (ECH2)	H2Fuel
Electricity		IF (Tran) AND (ECEl)	ElFuel
Ethanol		IF (Tran) AND (ECEt)	EthanolFuel
Biodiesel		IF (Tran) AND (ECBD)	BDFuel
Liquefied Petroleum Gas	LPG	IF (Tran) AND (ECLPG)	LPGFuel
Natural Gas	NG	IF (Tran) AND (ECNG)	-
Biogas	BG	IF (Tran) AND (ECBG)	BGFuel
Petrol / Diesel	Petrol/Diesel	IF (Tran) AND (ECPD)	PDFuel
<b>Water Supply</b>			
Water collection		IF (Water) AND (H2OPM OR H2OPH)	WaterC
Water wells		IF (Water) AND (H2OGM OR H2OGH)	-
Desalination		IF (Water) AND (H2OSY)	WaterD

<b>Waste</b>			
Incineration		IF (WasteHC)	-
Gasification		IF (WasteHC)	-
<b>Waste water treatment</b>			
Gasification		IF (WWTHC)	-

Table 23: Potential storage technologies

<b>Storage Technology</b>	<b>Condition</b>	<b>Code</b>
<b>Electricity storage system</b>		
Reversible Hydro	IF (WECS AND HECS)	-
Electrolyser + Hydrogen	IF (WECS OR SECS OR PV) AND NOT HECS	ELYH2
Reformer + Hydrogen	IF (ECNG OR ECBG OR ECPD OR ECEt OR ECLPG OR ECBD) AND NOT HECS	REFH2
Batteries	IF (SECS OR PV) AND NOT HECS AND NOT ECH2	-
<b>Heat Storage</b>		
Heat Storage	IF (HeatH)	-
<b>Cold Bank</b>		
Cold Bank	IF (ColdH)	-
<b>Fuel</b>		
Hydrogen	IF H2Fuel	H2stor
Ethanol	IF EthanolFuel	Ethanolstor
Biodiesel	IF BDFuel	BDstor
LPG	IF LPGFuel	LPGstor
NG	IF NGFuel	-
BG	IF BGFuel	BGstor
Petrol / Diesel	IF PDFuel	PDstor
<b>Water</b>		
Water	IF Water	WaterS
<b>Waste</b>		
Waste fill	IF Waste	WasteF
<b>Wastewater</b>		
Wastewater tanks	IF WWT	WWstor

Table 24: Integration of flows

<b>Integration Technology</b>	<b>Condition</b>	<b>Code</b>
Combined Heat and Power	IF (Elect PROPORTIONAL Heat) AND (DEGS OR CCGT OR FC OR BECS OR SECS OR GECS)	-
Combined Heat and Cold	IF (Heat PROPORTIONAL Cold)	-
Combined water and power	IF (HydroM OR HydroH) AND Water	-
Combined waste treatment and heat generation	IF (WasteI AND (HeatM OR HeatH))	-
Combined waste treatment and power generation	IF (WasteI AND (ElectM OR ElectH))	-
Combined waste Treatment and heat and power generation	IF (WasteI AND (ElectM OR ElectH) AND Elect PROPORTIONAL Heat)	-
Combined waste Treatment and heat, power AND cold generation	IF (WasteI AND (ElectM OR ElectH) AND Elect PROPORTIONAL (Heat + Cold))	-
Combined waste treatment and ethanol production	IF (WasteG AND ECET)	-
Combined waste treatment and gas production	IF (WasteG AND ECBG)	-
Combined wastewater treatment and gas production	IF (WWG AND ECBG)	-
Combined Power and Hydrogen Production	IF (WECS OR PV) AND ECH2	CPH2
Combined heat, power and hydrogen Production	IF (SECS OR BECS OR GECS) AND ECH2	3G-HPH2
Combined heat, power, cold and hydrogen Production	IF (SECS OR BECS OR GECS) AND ECH2	4G-HPCH2

The above logically leads to a range of choices that could be opted under the inputted data. It is to be noted that though some scenarios logically analyzed above are possible in Malta such as combined Heat and Power, practically they are excluded since the investment costs compared to the demand are too much offset. However, these scenarios can still be applied on a much smaller scale.



These are not investigated in the scenarios. From the other hand, though a hydrogen based scenario would imply a big investment cost, this is most likely to be feasible in the near future due to the ever increasing fossil fuel price and environmental awareness.

For Malta the main demands identified are electricity and transport. Though a lot of scenarios are possible, the scenarios to be investigated reflect targets agreed by the Maltese government and the European commission. The result mostly considered practical was the combined power and Hydrogen production. This was further elaborated leading to the following:

### **3.7.3. Modelling the scenarios**

#### **Scenario 1: Business as usual scenario**

This is a situation guided by existing local government policies (in terms of which uses are permitted where) and by the preferences of the marketplace (in terms of development densities and preferred locations) in which no change in current generation technology is used. The expected demand pattern must first be forecasted from the knowledge of population growth and population variation (tourism), the evolution of comfort levels requirements and previous years load demands. Based on the derived demand pattern, the Business as Usual can be simulated: it implies the characterisation of the power generation capacity in place, and possibly of additional conventional capacity if required. The so-called peak load must then be defined and estimated. This Scenario is based on both technical and economic analysis since it investigates also the economics associated with such a project. However, the design chosen for the resulting energy system is a function of the set of technical constraints and boundary conditions, and not of the cost of power generation.

This involves the analysis of the investment and upgrading necessary in order to cater for the load demand up to year 2025. This analysis assumes an N-1 situation in which it is assumed that at any time there will be one generating block, equivalent to the biggest block, either in maintenance or stand by mode. This available generating capacity will be able to cater for the so-called peak load. This Scenario is based on technical analysis and investigates the economics associated with such a project in order to benchmark the price of electricity produced by such practice.

#### **Scenario 2: Fossil Fuel and low level penetration of wind and solar scenario.**

It is correct to say that, power coming from RE up to 30% will not greatly affect or disturb the synchronous operation of a generating system for small isolated generating systems. Apart from this, technological advances such as pitch control will further more help in the integration of

Renewables in isolated systems. A low and practical level of renewable penetration, apart from fulfilling our EU Directive on the promotion of energy produced from RE sources also implies that there will be no excess energy produced. Thus all wind and solar energy produced will be supplied to grid with no storage necessities. Thus, this scenario will try to meet the 5% target of electricity produced from RE sources set in the Accession Treaty of the EU Directive on the promotion of electricity from RES. This 5% is further increased to 11% by 2015 which then remains so until 2025. Here again, the combination chosen is a set of technical limitations and practical constraints. The electricity cost and adjustments necessary to make this scenario sustainable is finally analysed and presented.

### **Scenario 3: Fossil Fuel, RE and Hydrogen storage scenario for the transport sector.**

Hydrogen has been seen as a new energy vector and can be specially suited for islands and remote regions, when produced in a renewable way, because it increases the security of supply and opens the renewable market for other areas, as for instance transport. This is a scenario introducing a hydrogen load to be used by road transport. This is produced from wind and solar sources satisfying a 5% transport energy demand in 2015 and 10% in 2025. RE will be directly converted to hydrogen in order to cover the necessary load to be used for transport. Excess intermittent energy is supplied to grid via fuel cells provided a certain security of supply is reached. Thus, in this way of approach, the irregularity of wind energy produced is cancelled and can be used in time of peak loads by the use of fuel cells implying an increase in the overall efficiency and a reduction in the emissions.

## **3.8. Calculations, logic and conditions.**

### **3.8.1. Scenario 1: Business as usual scenario.**

Traditional policies usually assume a Business as usual concept in order to devise their projections. However, there are also different variants to this system. At the moment Malta operates with an N turbine system implying that typically, all turbines will be operating at peak time. Whilst that this might seem as an efficient utilisation of existing blocks it also means that the security of supply is also threatened. In order to have a certain level of flexibility, at least an “N-1” system must be implemented. This, sometimes also referred to as “N+1”, implies a situation where the user can still cover its peak demand even without his biggest available block. It is also defined as that under all operating conditions, the loss of any given element (line, transformer, generating unit, compensation facility etc.) will not lead to operating constraints and will not cause interruptions in supply. The “all operating conditions” usually assumes blocks to be either in repair or else in

maintenance status. The herewith presented and designed system is based on this redundancy condition and although this for some might seem not providing enough redundancy (considering that some countries also operate on N-2 or N-3 system), this is at least the minimum generally acceptable level of operation.

The first simulated case involved having no other generating machines installed. That is to determine the limit up to which year the installed generating power can handle. Assuming that all the generators will be working and delivering their maximum output the current system will start experiencing problems in year 2010. With the projected load demand for that year, a capacity shortage of about 0.06% will be experienced. It follows that from then on, this capacity shortage will increase reaching a 4.3% level in 2015 reaching levels of 15.23% in 2020. This is obviously the ideal situation since one has to keep in mind that some generator redundancy must always be available in case of some faults and maintenance. In practice, this is also not possible since some generators are old and cannot withstand long working hours. In fact, at the moment these are just used to cover peak load demand.

This led to the second simulation set, having some amount of reserve capacity. This was set to approximately 20% (110 MW out of 571 MW) of the total installed generating power. This is a more practical situation. Results and problems show that some problems would have been experienced between year 2005 and 2006 with a 0.09% shortage, 2.5% shortage in 2010 and an impressive 11.5% shortage in 2015. The shortage between year 2005 and 2006 was not so much felt due to the influence of the mild winter and summer. This scenario starts to give an idea when the installation and operation of new generating units should take place. It is well known that tendering and consultation period together with the installation and commissioning time necessary, usually takes a long time. Thus this has to be considered in the project.

After these two exercises were performed, the estimated generator size to cover projected load was calculated. This involves estimation of size and technology in our case for five year periods up to year 2025. In this BAU, it is assumed that there is no fuel change. Thus the newly introduced generating engines would be operating on either gas oil or heavy fuel oil as it is the case right now. However, due to increased efficiency measures, the introduced engines would most probably be a Combined Cycle Gas Turbine (CCGT) or diesel generators, operating at full load and using the other old inefficient engines to cover peak loads.

The overall logic of the financial analysis is presented in section 3.9. This section aims to give a better insight of the deviations or add on to the basic logic flow. Keeping in mind that there are

already some existing power plants in operation in Malta, whilst new ones have to be included, this needs to be separately considered. The O&M costs together with the level of efficiency have to be separately considered and tackled. H<sub>2</sub>RES permits the inputting of multiples of six maximum number of blocks. All of these permit to alter the block power, the minimum load and efficiency. In the financial analysis part, however, this was divided into two different systems. The first system is composed of old power plants operating at 25% efficiency, an overall typical efficiency also quoted in [46] where it states that “the overall efficiency of power generation has increased from about 23% in 1991 to almost 28% in 2000”. The second system of proposed generating plants is to employ more developed technology, thus higher efficiency figures. A 40% efficiency was considered for the new blocks (Refer to Table 25). This was based on available practical data and theoretical data where it is stated the highest efficiencies are being achieved by combined cycle plants, efficiencies of over 50% are routinely achieved and efficiencies approaching 55% are possible [75].

**Table 25: Comparison of used data for existing and new plants**

<b>Existing plants @ 25% efficiency</b>		<b>New plants @ 40% Efficiency</b>	
kJ/kWh	13440	kJ/kWh	10752
kg of fuel/kWh generated	0,32	kg of fuel/kWh generated	0,256
fuel cost / kWh (Euros)	0,123	fuel cost / kWh (Euros)	0,0984
fuel cost / kWh (c€)	12,3	fuel cost / kWh (c€)	9,8399

The cost for the installation of new fossil fuel blocks (including the blocks themselves) was considered at 1000 Euros per kW with an O&M cost of 2% for new blocks and 5% for old blocks. This installation price is based on different studies, also presented in [76]. This is due to the fact that since existing blocks are older, their maintenance costs tends to be greater. The life time of the installed new blocks was set to 20 years.

The cost of fuel oil was also needed in order to be able to perform our financial analysis. With ever increasing costs in the price of a barrel of oil, (refer to Figure 48) there is no real value that could reflect the cost of oil for a long period of time. However, in order to be able to complete this study a price had to be concluded. The price of one barrel of oil was set to 55 Euros (approx. 80\$), considering that Malta usually has to pay more due to transportation costs of the fuel.

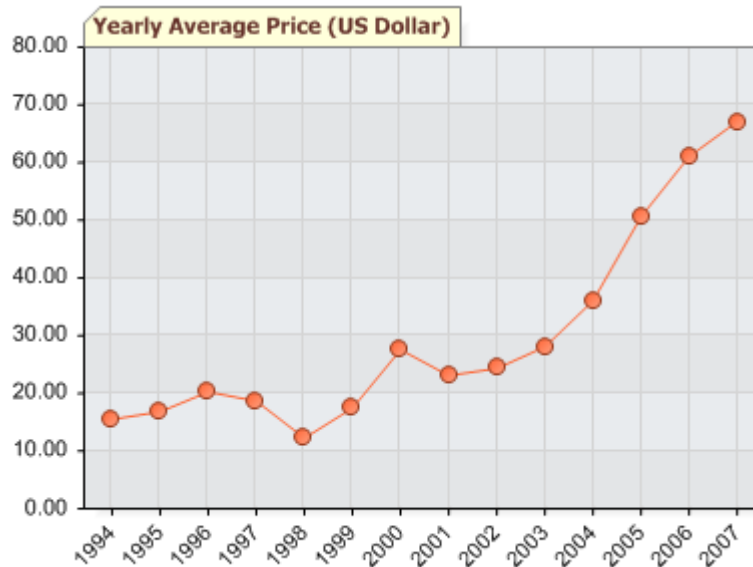

Figure 48: OPEC annual average crude oil price per barrel [77][78]

Since in Malta the only generating utility is government owned, it is most probable that this investment would be accompanied by relatively lower discount rates (6%) even though high financing costs will be necessary. This also applies for renewable energy projects which are likely to be supported by government in order to accomplish his Kyoto targets. The required investment every 5 year period is planned to be funded 100% through a loan, the term being 20 years, and the final electricity price is to reflect the cost price i.e. price without any profit. The entire loan is assumed to be disbursed in the first year at the start of the year (and hence will also incur interest costs during the first year). The investment is assumed to be a mid-period investment i.e. the blocks needed to cover year 2010 peaks will start to be installed/operated 2-3 years before i.e. 2007/08 thus also covering part of the load of year 2008 and 2009. The same applies for other investment periods and other technologies used.

### 3.8.2. Scenario 2: Fossil Fuel and low level penetration of wind and solar scenario.

The second scenario is designed to incorporate blocks aiming to produce energy from Renewable energy. In order to start designing such system, it was imperative that one understands exactly the importance of the term “security of supply”. Although it is always envisaged that renewable energy is a way of reducing our dependence on fossil fuels, yet the reliability of security of supply for fossil fuels is still much higher than that provided by RES. In fact, this second scenario was based on that of Scenario one earlier described and adding extra renewable generation blocks. The term capacity credit is usually mentioned in such scenario. The concept of “Capacity Credit” is an arcane

idea used by utility planners in ensuring that the lights stay on. For an island like Malta, where no connection to the grid is at the moment possible one has to carefully weigh the reduction in fossil fuel blocks replaced by RES blocks. Usually a 0.04% is applied. This practically means that Scenario 2 has to be composed of roughly the same generating power capacity of Scenario 1. One would obviously ask, what is the use of RES then. The answer to such question is attained by analysing the expenses involved in fossil fuel blocks. Compared to RES, the majority of the price-weight of fossil fuel blocks lies in the fuel itself and not in the generating blocks. On average the investment in a fossil fuel block over a 20 year period is approximately one tenth of what is spent in fuel. Then, should wind and solar sources in some way or another not be present, the load can be covered by fossil fuel blocks which basically have the ability to cover all the load.

In order to simulate the second scenario, it was necessary to include different variables. For the case of photovoltaic, a realistic value of the nominal efficiency of the PV, the average efficiency of the converter and the losses co-efficient had to be included. These were set to 0.15, 0.92 and 0.85 respectively. This led to an overall efficiency of 0.1173 or 11.73%. Higher values are now present in today ever developing technology, however, in order to use “mature technology” these values were adopted.

For the case of wind turbine systems, the available data from manufacturers was used. The graph of the performance of these wind turbines was earlier presented in Figure 9.

### **3.8.3. Scenario 3: Fossil Fuel, RE & Hydrogen storage scenario for the transport sector**

The third scenario is a scenario based on the integration of six technologies: Fossil fuel blocks, wind turbines, photovoltaic, electrolyser, hydrogen storage and fuel cell. In order to maintain and operate these technologies, it is important that the blocks are chosen according to certain boundary conditions. These are listed hereby.

- The hydrogen storage should provide 240 hours (10 days) of reserve. i.e. the hydrogen storage should be large enough to handle the load demanded by cars for ten days. This ensures a certain security of supply.
- In the simulations, hydrogen peak storage was set to 80%. This is the storage used for peak shaving when the load is above threshold related to weekly peak.
- The stored daily hydrogen should never be zero.

- The yearly hydrogen storage stock difference should be around  $\pm 2.5\%$ , ideally zero percent.
- The intermittent rejected energy from Renewable sources should be less than 10%.
- The yearly hydrogen stored should be greater than the yearly load.
- The yearly load factor of the fuel cell should be at least 1500 hours or more. This ensures that the fuel cell will operate at least 20% of the year.
- Fuel Cell Efficiency set to 60%.
- Electrolyser efficiency including compression set to 80%.
- The intermittent limit i.e. the amount of intermittent power that can be accepted by the grid in one hour was set to 30% in order to ensure that there will not be high voltage and frequency fluctuations.

Based on the above conditions, a good combination of all technologies is possible without having too much energy being dumped.

The aim of this scenario is to produce hydrogen for transport and the excess energy produced from renewables will be used for electricity generation. The logic of the simulation was earlier discussed. The hydrogen scenario, apart from including other technologies used in the first and second scenario, also includes three other technologies: hydrogen storage, electrolyser and fuel cells. All of these have to be dealt with, including payment and investment. The time frame or the launch of this scenario is a realistic one that respects the research and development yet to be done and the maturity of such technology. In fact this is a scenario that is identical to Scenario 2 until year 2010 and then integrates additional modules and blocks from then on to achieve different results. This scenario sees the full operation of all hydrogen technology blocks as from year 2015. The respective initial investment together with operation and maintenance and payment each year over a 20 year payment period are calculated for every 5 year investment intervals, thus having 3 investments available...2013-2017, 2018-2022, 2023-2027 covering loads estimated at year 2015, 2020 and 2025 respectively. All the calculated yearly payments are then added up after being transferred to the 0<sup>th</sup> year and then separated into 20 equal payments using Excel's PMT function. Dividing by the projected yearly generation leads to an average cost per kWh.

### **3.9. Financial Analysis**

Whilst that a modern investment approach has been suggested in [41] aiming to look at the true relative value of Renewables or better said evaluating systems on its portfolio rather than on its stand alone cost, an Engineering Economics Approach was used in order to calculate the cost of kWh. This was applied until year 2025 for every 5 year period investment. Further more, this was applied to all scenarios, thus including different technologies. This varied from a “relatively simple” mono technology operation and maintenance costs together with fuel costs for the first scenario to a more complex tri-technology second scenario to a final multi-technology third scenario.

The following is a typical approach used in calculating the price for every scenario. The necessary additional power that had to be added every 5 years in order to cover load demand was calculated using H<sub>2</sub>RES applying the projected load increase to the base year 2002. Thus the necessary blocks needed at year 2010, 2015, 2020 and 2025 was found. This was done until year 2025, i.e. a total of five, 5 year investments. The cost of the additional generating blocks together with the related operation and maintenance costs was calculated for each year using typical average cost per kWh over the economic life of the project. The resulting series of annual cash flows were discounted by a discount rate of 6% (a rate used to convert future costs to their present value). This transferred all the project lifetime costs to an initial year of the period. Adding all these transferred costs and dividing by the projected load leads to the cost per kWh. The fuel cost per kWh was not transferred to its present value since it was assumed that this would be bought yearly not every five years.

This procedure was basically applied to each technology used under each Scenario. In the first scenario, fossil fuel blocks and fuel were considered. In the second scenario this was expanded to include wind and solar photovoltaic. In the third scenario, the financial costs had to be further expanded to include all those in scenario 2 and also hydrogen equipment such as storage, electrolyser, fuel cells...etc. These costs have to be added proportionally according to what needs to be calculated. Three typical costs were necessary to be found under Scenario 3:

- The first is the cost per kWh of hydrogen stored.
- The second is the cost associated with electrolyser in order to be able to produce hydrogen from water.
- The third is the cost associated with producing electricity from hydrogen thus utilising fuel cell.



Two final costs have to be calculated:

- Cost of hydrogen for cars (percentage of which includes storage)
- Cost of electricity from hydrogen (using fuel cell).

The cost of hydrogen for cars is calculated using the share of the hydrogen storage equivalent to that used for this purpose together with the cost associated with producing this hydrogen i.e. the cost incurred by the electrolyser to produce hydrogen specifically for the hydrogen load for transport.

$$\text{Equation 12: } H_2 \text{ cost}_{trans} = \left[ \frac{H_2 \text{ electrolysed}_{trans}}{H_2 \text{ electrolysed}_{tot}} \right] \text{payment}_{electrolyser} + \left[ \frac{H_2 \text{ utilised}_{trans}}{H_2 \text{ stored}_{tot}} \right] \text{payment}_{storage}$$

Where:  $H_2 \text{ cost}_{trans}$  is the yearly cost of hydrogen for transport.

$\text{payment}_{electrolyser}$  is the yearly payment for installed electrolyser

$\text{payment}_{storage}$  is the yearly payment for installed hydrogen storage

$H_2 \text{ electrolysed}_{tot}$  is the yearly total of hydrogen electrolysed

$H_2 \text{ electrolysed}_{trans}$  is the yearly amount of hydrogen electrolysed, actually being used for transport

$H_2 \text{ utilised}_{trans}$  is the yearly amount of hydrogen that is actually utilised for transport

$H_2 \text{ stored}_{tot}$  is the yearly total amount of hydrogen stored.

Dividing  $H_2 \text{ cost}_{trans}$  by the yearly transport hydrogen load would provide the price per kWh.

The second cost involved that for the production of electricity from hydrogen. This involves the rest of the share for hydrogen storage together with the costs associated for this purpose for both converting water into hydrogen and with the fuel cell costs associated to convert hydrogen back to electricity.

Equation 13:

$$Elec_{H_2 \text{ cost}} = \left[ \frac{H_2 \text{ fuelcell}_{tot}}{H_2 \text{ electrolysed}_{tot}} \right] \text{payment}_{electrolyser} + \left[ \frac{H_2 \text{ fuelcell}_{tot}}{H_2 \text{ stored}_{tot}} \right] \text{payment}_{storage} + \text{payment}_{fuelcell}$$

Where:  $Elec_{H_2 \text{ cost}}$  is the yearly cost of electricity produced from hydrogen.

$\text{payment}_{electrolyser}$  is the yearly payment for installed electrolyser

$\text{payment}_{storage}$  is the yearly payment for installed hydrogen storage

$\text{payment}_{fuelcell}$  is the yearly payment for installed fuel cells

$H_2 \text{ electrolysed}_{tot}$  is the yearly total of hydrogen electrolysed

$H_2 \text{ fuelcell}_{tot}$  is the yearly total amount of hydrogen utilised by fuel cell for electricity conversion.

$H_2 \text{ stored}_{tot}$  is the yearly total amount of hydrogen stored.

Dividing  $Elec_{H_2 \text{ cost}}$  by the yearly fuel cell supplying demand would provide the price per kWh of electricity generated from hydrogen including the associated expenses.

Where it follows that

Equation 14: 
$$H_2 \text{ fuelcell}_{tot} \cong (1 - H_2 \text{ electrolysed}_{trans}) \cong (1 - H_2 \text{ utilised}_{trans})$$

### 3.10. Malta obligations under Kyoto Protocol

Whilst that Kyoto percentages are commonly known, Malta's position under the Kyoto Protocol is quite a particular one. In fact Malta and Cyprus, since they became EU members after the signature of the Kyoto protocol, had the time to delay their obligations to become annex I/II/B states and thus have no commitment for emissions reduction. However, as EU members they are obliged to participate in the EU ETS.

In adopting the Emission trading scheme [79], a lot of mechanisms were created, the CDM and the "cap and trade" method being the ones Malta can take advantage of. In fact, Directive (2003/87/EC) puts in place "cap and trade" framework for emissions and emissions control. The Directive creates an emission allowance unit (EAU) and establishes a permitting scheme for participating installations [44]. The purpose of this permit is to place an obligation on each operator.

Such a scheme is mostly applicable to the case of Malta in case it intends to comply with the directives itself. Such a scenario is assumed in this thesis and units are referred to as such. A feature of this Directive is that it encourages the linking of EU ETS with other similarly rigorous emission trading schemes in non-EU Annex 1 Countries, in particular those that ratified the Kyoto Protocol.

The CDM mechanism is also a tool that can help in the implementation of Renewable energy projects in Malta and small islands. Such a scenario was similarly analysed in [80] and further elaborated in [81], [82] and [83]. The unit CER (Certified Emission Reduction) unit is a climate credit (or carbon credits) issued by the Clean Development Mechanism (CDM) Executive Board for emission reductions achieved by CDM projects under the rules of the Kyoto Protocol. CERs can be used by Annex 1 countries in order to comply with their emission limitation targets or by operators of installations covered by the European Union Emission Trading Scheme (EU ETS) in order to comply with their obligations to surrender EU Allowances, CERs or Emission Reduction Units (ERUs) for the CO<sub>2</sub> emissions of their installations. These CERs are obtained by Annex 1 countries after investing in clean technologies in non-Annex1 countries.

The system is explained in Figure 49 where Annex 1 countries can invest in projects in Malta thus gaining credits for their country which would cost much more, to the advantage of both.

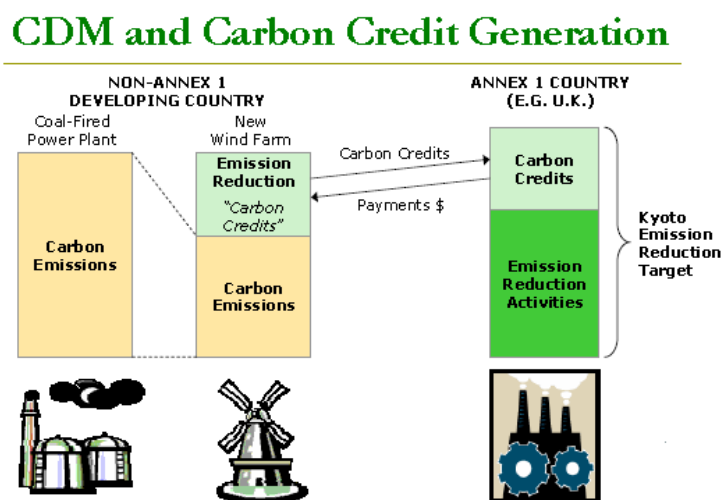
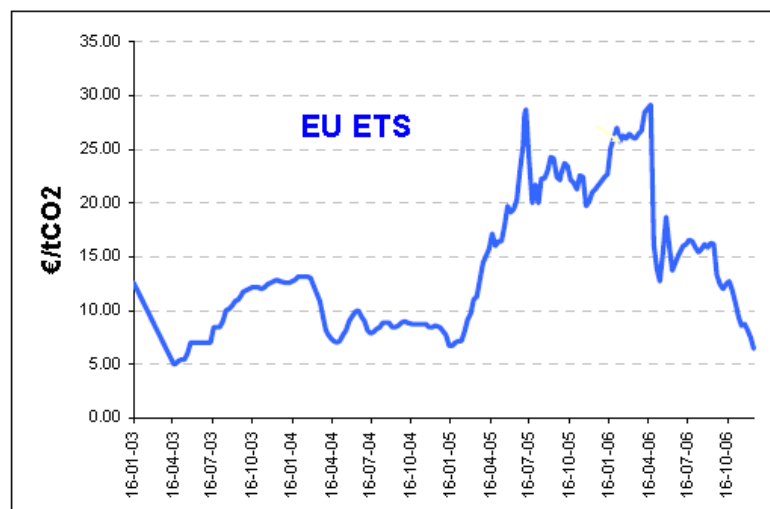

Figure 49: Clean development mechanism [84].

National allocation plans (NAP) determine for each Member State the 'cap,' or limit, on the total amount of CO<sub>2</sub> that installations covered by the EU ETS can emit. Intelligent and studied investment can give Malta the possibility to gain credits that could be sold thus with the possibility of reducing the overall price of a kWh of energy produced from renewables. In its National

Allocation Plan for period 2008-2012, [85] Malta requested 5,594,755 tonnes of CO<sub>2</sub> for Marsa power station and 5,555,684 tonnes of CO<sub>2</sub> for Delimara power station totalling to 11,150,439 tonnes of CO<sub>2</sub> over the 5 year period, thus averaging to 2,230,087.8 tonnes of CO<sub>2</sub> per year. A reserve allocation for the 5 year period of 3,831,328 tonnes of CO<sub>2</sub> has been set aside for new entrants- this is equivalent to 25.9% of the total requested. Thus the total requested limit for the five year period was 14,777,981 tonnes of CO<sub>2</sub> or approximately 2.9Mt CO<sub>2</sub> yearly for period 2008-2012. However, the European Community approved only 2.1 MtCO<sub>2</sub> per year [90] i.e. 10,715,000 tCO<sub>2</sub> (also called allowances or Quota) for the period 2008-2012 thus leaving Malta with a shortage of 4,062,981 tCO<sub>2</sub> over a 5 year period or 812,596 tCO<sub>2</sub> per year. This is approximately 8% reduction over the 1990 emitted levels (Table 26). Thus excluding the reserved part for new entrants and keeping the same percentage share, Enemalta has been allocated 74.1% of 10,715,000 tCO<sub>2</sub> i.e. 7,939,815 tCO<sub>2</sub> over the five year period averaging to 1,587,963 tCO<sub>2</sub>/year.

In order to cover these missing tonnes, a utility can either buy carbon credits or else invest in clean technology thus having available even more of these credits. The prediction of this carbon price is not an easy task. It is a fluctuating price (Figure 50) being a function of a lot of factors. Such factors include the maturity, lack of experience and loop holes of the mechanism, allocated quotas to countries, banking (possibility of transferring carbon credits and allowances that are not used in one compliance period to a future period), penalties and targets after the 2008-2012 period.



**Figure 50: CO<sub>2</sub> Price evolution in EU ETS (Point Carbon)**

Market price of tonne of CO<sub>2</sub> trading is dependent on the trading regime and risk management options. However, from historic and recent trading, this shows average prices from €5-15/tonne

CO<sub>2</sub> in period 2005-2007 with high probability that prices will be higher during the second phase (2008-2012).[86]

The legal base for allocations for the 2013-2017 trading period will be the same as for the 2008-2012 trading period, unless amended through the review process. Therefore, the Commission would expect to apply the same approach and principles to the assessment of national allocation plans submitted for the 2013- 2017 trading period as used to assess the 2008-2012 plans. [87]. Having a "clear political commitment to at least 20%" (on 1990 levels),[88] typical targets of CO<sub>2</sub> caps can be estimated. An estimated 30% reduction is then applied for period 2023-2027.

**Table 26: Carbon dioxide emissions [89]**

Carbon dioxide emissions								
CO <sub>2</sub> emitters	Total emissions (MtCO <sub>2</sub> )		CO <sub>2</sub> emissions annual change (%)	CO <sub>2</sub> emissions share of world total (%)		Population share (%)	CO <sub>2</sub> emissions per capita (tCO <sub>2</sub> )	
	1990	2004	1990-2004	1990	2004	2004	1990	2004
United States	4,818.3	6,045.8	1.8	21.2	20.9	4.6	19.3	20.6
China	2,398.9	5,007.1	7.8	10.6	17.3	20.2	2.1	3.8
Russian Federation	1,984.1	1,524.1	-1.9	8.8	5.3	2.2	13.4	10.6
<b>Malta</b>	<b>2.2</b>	<b>2.5</b>	<b>0.7</b>	<b>0.0</b>	<b>0.0</b>	<b>0.0</b>	<b>6.3</b>	<b>6.1</b>
<b>Global aggregates</b>								
High-income OECD	10,055.4	12,137.5	1.5	44.3	41.9	14.3	12.0	13.2
High human development	14,495.5	16,615.8	1.0	63.9	57.3	25.5	9.8	10.1
World	22,702.5	28,982.7	2.0	100.0	100.0	100.0	4.3	4.5

In order to obtain a reduction of 20% for period 2018-2022, a typical percentage for period 2013-2017 would be 14%. The latter would lead to a CO<sub>2</sub> emission limit of 1.9M tCO<sub>2</sub> yearly for period 2013-2017 and a CO<sub>2</sub> emission limit of 1.7M tCO<sub>2</sub> yearly for period 2018-2022. The financial calculations are based on these assumptions and presented in Section 4 and 5.

## 4. Results

### 4.1. Scenario Results

#### 4.1.1. Scenario 1: Business as usual scenario.

Results depict, with the simulated load growth demand, the load shortage experienced. In an N-1 configuration (110 MW out of 571 MW) of the total installed generating power, results show that some problems will start to be experienced between year 2005 and 2006 with a 0.09% shortage, 2.5% shortage in 2010 and an impressive 11.5% shortage in 2015. This shortage in generation capacity, in this scenario, can be resolved by installing different fossil fuel blocks as shown in Figure 51 every 5 year period.

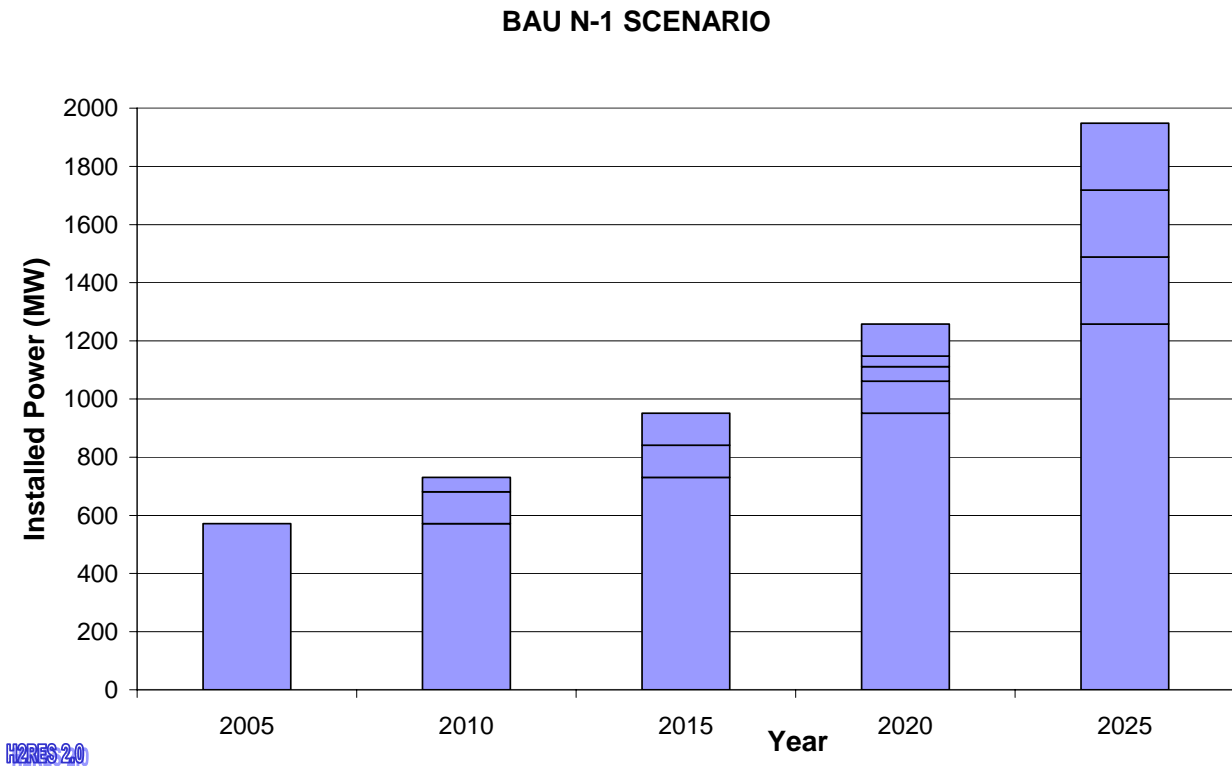

Figure 51: Blocks needed to be installed in a BAU N-1 Scenario

Period 2005 to 2010 involves the installation of two fossil fuel blocks, 110 MW and 50 MW respectively. This has to be further extended by adding 2 more blocks in the period 2010-2015 consisting of 110 MW each. Ideally these blocks should cater to best fit our situation i.e. a bigger combined cycle gas turbine to offer higher efficiency. Period 2015-2020 sees the investment of 4 blocks; 2 of 110 MW each, one 37 MW block and one 50 MW. The latter should be some sort of

fast generating power type such as gas turbines to offer immediate electricity generation during peaks. Finally period 2020-2025 sees the elimination of some old blocks being substituted by bigger generating blocks. Three blocks of 230 MW each are thought to be introduced in the system.

**Table 27: Scheme of installed fossil fuel blocks according to simulations**

FOSSIL FUEL BLOCKS (MW)							
	230	120	110	74	37	50	TOTAL
2005	1	1	1	1	1	0	571
2005-10	1	1	2	1	1	1	731
2010-15	1	1	4	1	1	1	951
2015-20	1	1	6	1	2	2	1,258
2020-25	4	1	6	1	2	2	1,948

H2RES 2.0

SUPPLYING DEMAND - 1ST SCENARIO

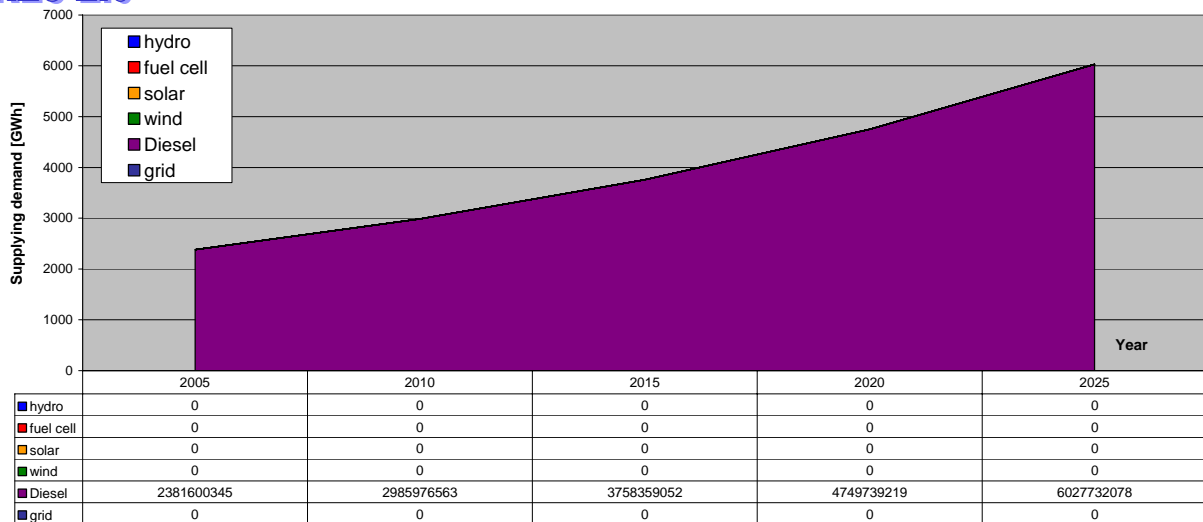

**Figure 52: Supplying demand for a BAU N-1 scenario according to projected growth**

On analysing the financial aspects of the simulation, one has to note the relative small difference between the cost of fuel and the price per kWh. This could be seen by comparing the fuel cost in Table 25 to the cost of electricity in Figure 53. The unlevelised cost of 12,3 c€/kWh for 25% efficiency engines and 9,8 c€/kWh for 40% efficiency is not much different from the average price per kWh of that shown in Figure 53. In a scenario based on fossil fuel blocks, the main investment lies in the fuel cost rather than in the equipment. Providing redundancy with fossil fuel blocks is thus a common practice since this is not the greatest cost for fossil fuel generation. The effect on the price of the mid period investment could be immediately seen.

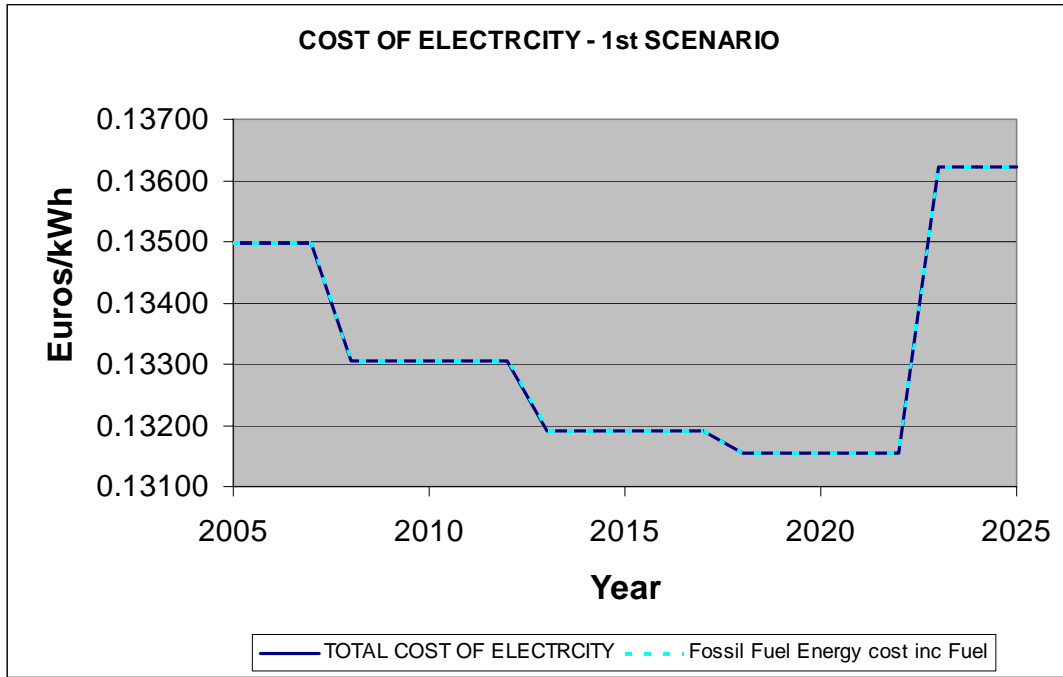
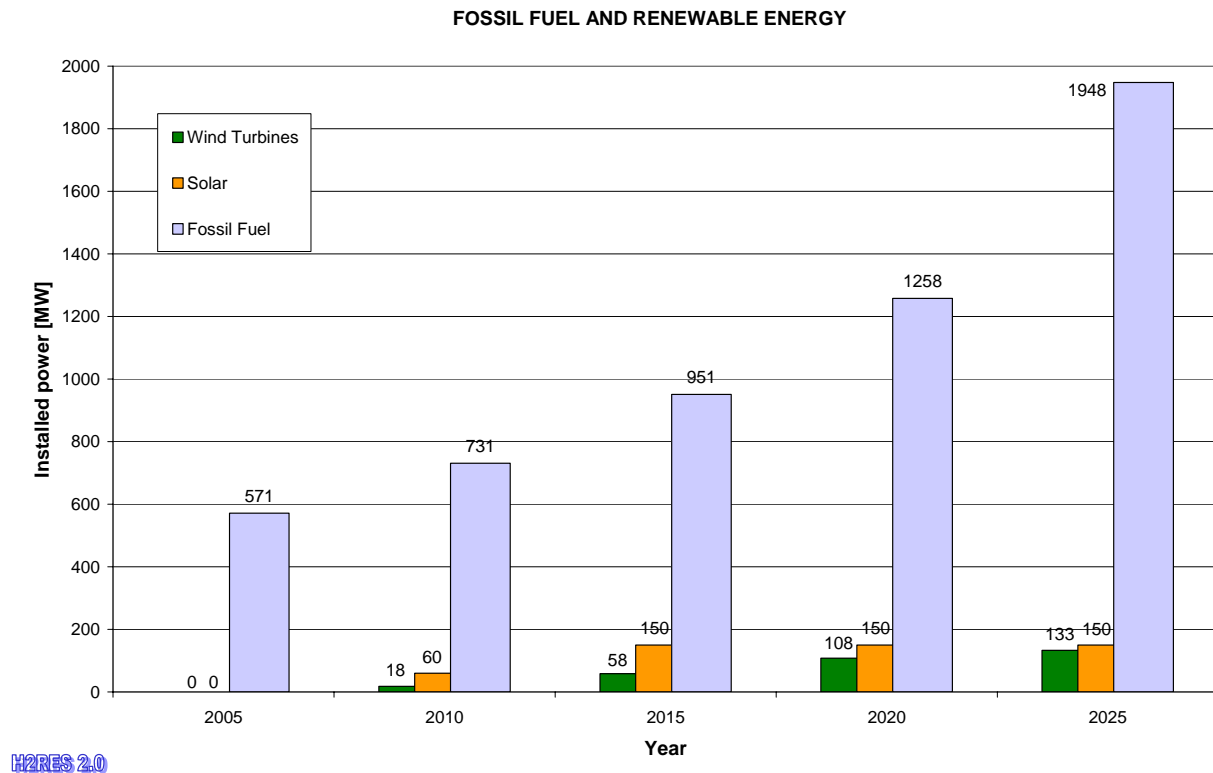

Figure 53: Financial analysis results of a BAU N-1 scenario based on projected values

**4.1.2. Scenario 2: Fossil Fuel and low level penetration of wind and solar scenario.**

This scenario aims to fulfil the Accession Treaty of the EU Directive on the promotion of electricity from RES i.e. to produce 5% of total energy from renewables by 2010. This percentage is achieved by the installation of 18,000 kW of Wind turbines and 60,000 kW of PV panel as shown in Figure 54. This leads to a 1.74% and 3.43% of RE produced respectively. This 5.17% is further increased to 10.50% by the installation of 40,000 kW more of wind turbines and 90,000 kW of PV in 2015. From then on, the renewable percentage is maintained approximately the same i.e. 11.19% in 2020 and 10.10% in 2025. This is achieved by maintaining the same amount of PV panels present in year 2015 and investing in bigger wind turbines. Ten 5 MW wind turbines are being proposed to start operate in year 2020 and 15 of these in year 2025.





**Figure 54: Installed power in a scenario 2 according to projected load growth**

**Table 28: Scheme of Installed FF Blocks, WT and PV panels according to simulations.**

	FOSSIL FUEL (MW)							WIND (MW)			PV (m <sup>2</sup> )
	230	120	110	74	37	50	TOTAL	1.8	2	5	-
<b>2005</b>	1	1	1	1	1	0	571	0	0	0	0
<b>2005-10</b>	1	1	2	1	1	1	731	10	0	0	400,000
<b>2010-15</b>	1	1	4	1	1	1	951	10	20	0	1000,000
<b>2015-20</b>	1	1	6	1	2	2	1,258	10	20	10	1000,000
<b>2020-25</b>	4	1	6	1	2	2	1,948	10	20	15	1000,000

Great care must be taken in this respect. One has to consider the maturity of the technology used together with the levels of penetration in order not to introduce unacceptable frequency fluctuations. A 30% instantaneous penetration of intermittent renewables was used. The 2010 figures are achieved by the installation of 10\*1.8 MW wind turbines and 60,000 kWp PV. This is further increased to include 20\*2 MW wind turbines and 90,000 kWp PV. The Vestas V90 WT, capable of providing high output in modest winds, was used in the simulation. An overall efficiency of the PV system was set to 11%, however, this is expected to increase with current studies and research in the field. Such levels of PV percentage though at first instance might seem too much, is actually being

achieved and planned. Such a project with a 62 MW PV plant is in planning process in Portugal [99]. The 2-3 Mega watts wind turbine range technology is the most mature technology in this field and was thus chosen as the wind component for the initial period. Considering the study being done in this field, the 5 MW turbine family would be mature by year 2020 and hence are introduced to cater for bigger demands whilst maintaining approximately the same percentage of renewable energy.

On analysing current RE technology prices, one realises that PV panels are much more expensive than Wind turbines. However, one must be aware that for such a small Island like Malta with deep waters around, a higher level of PV is inevitable unless Wind Turbine Technology matures in deep offshore installation. Further more, this in some way or another outweighs the tourism power needs during summer time.

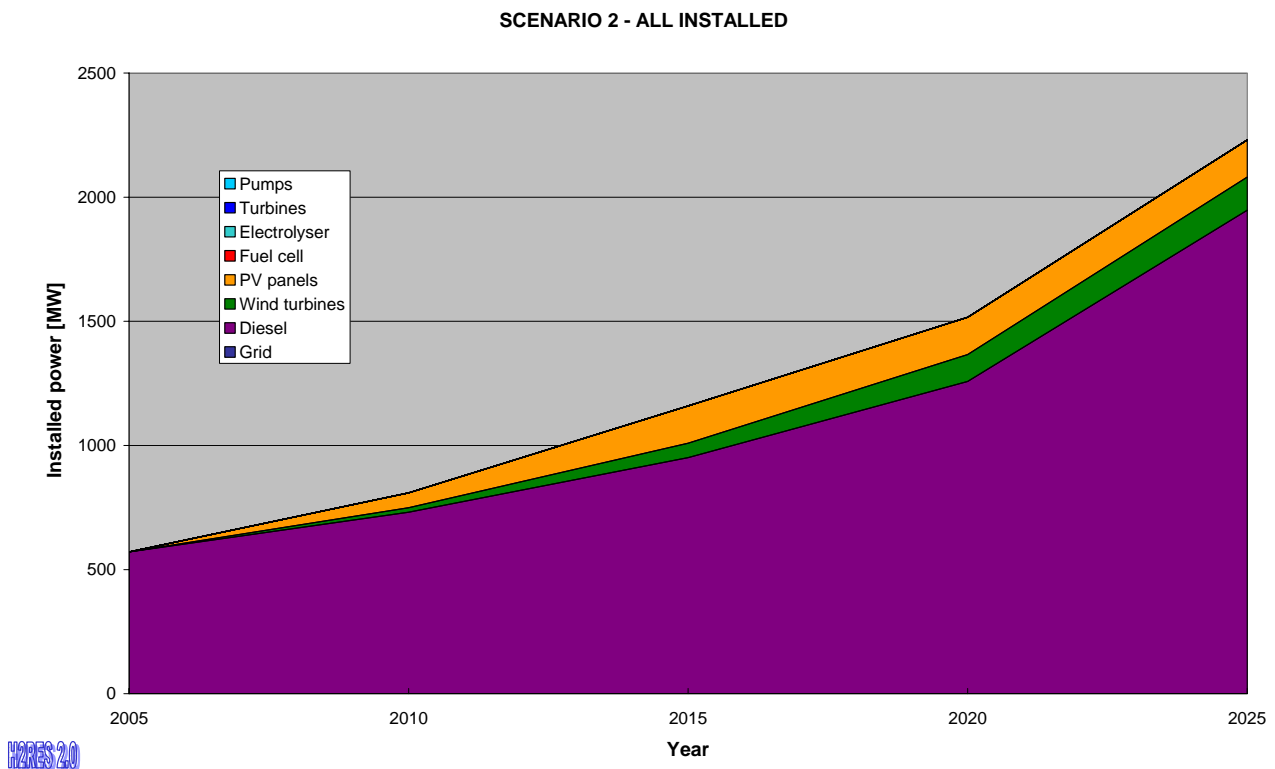

Figure 55: All installed scenario 2.

H2RES 2.0

SUPPLYING DEMAND - 2ND SCENARIO

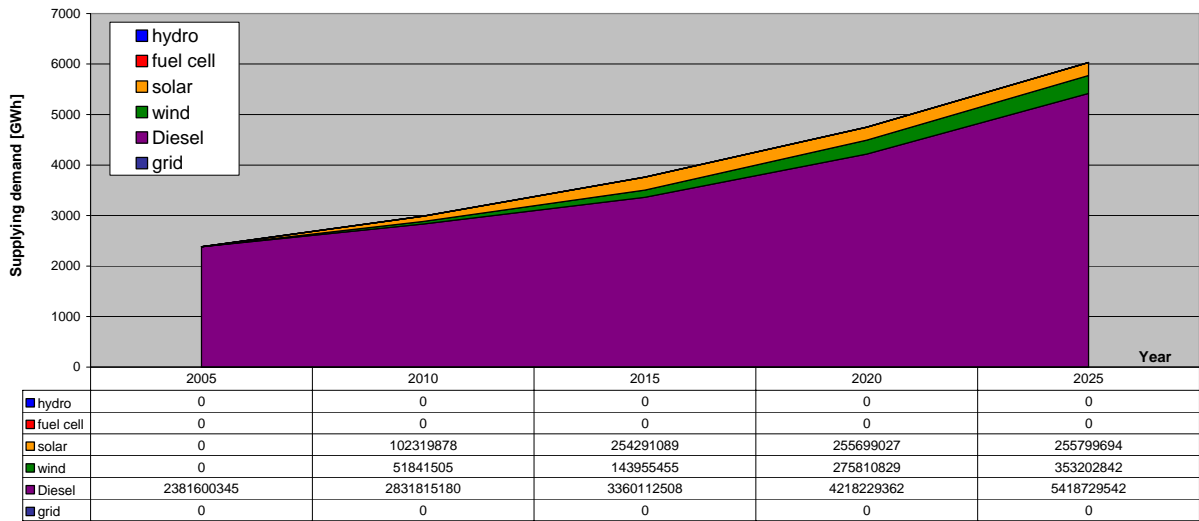

Figure 56: Supplying demand 2<sup>nd</sup> scenario

H2RES 2.0

INTERMITTENT POTENTIAL - 2ND SCENARIO

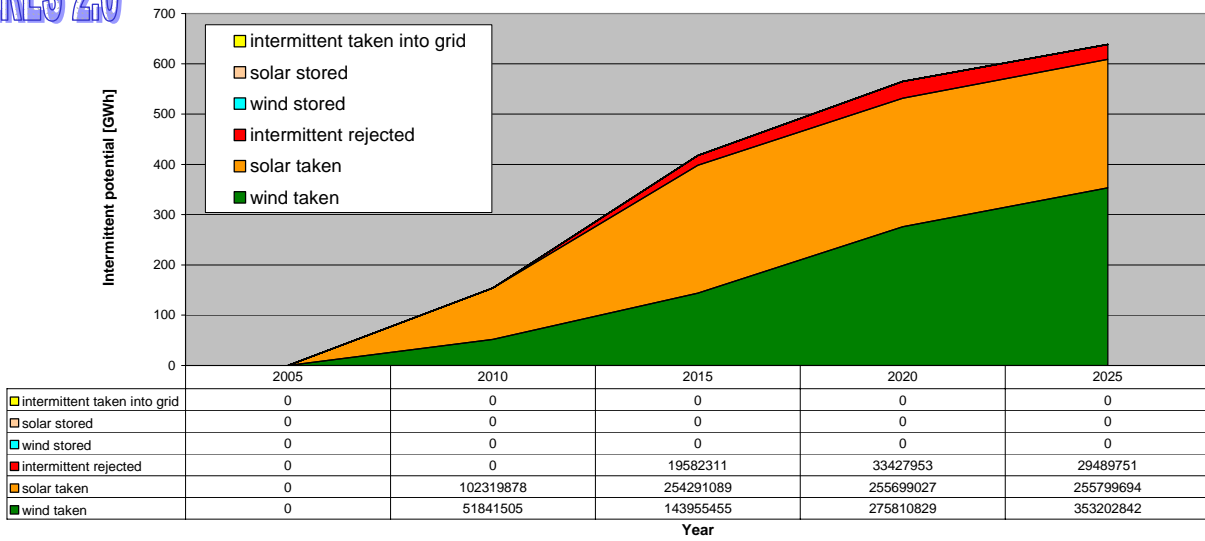
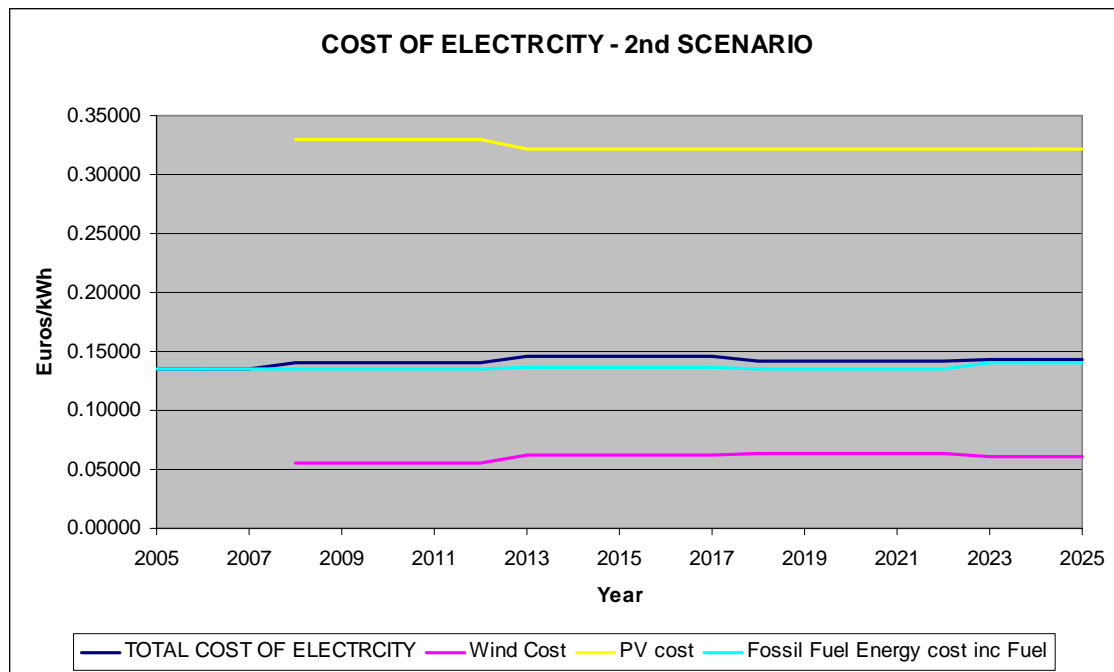

Figure 57: Intermittent potential for scenario 2.



**Figure 58: Financial analysis results of second scenario based on projected values**

Calculations and their results in Figure 58 for scenario 2 present the cost of each individual technology and that of the total cost of electricity. Whilst that the cost of electricity per kWh from fossil fuel remains approximately the same as compared to scenario 1, the overall cost of electricity increases a little bit due to the high expenses involved in PV technology. However these are counter balanced by the low cost per kWh of wind energy lying approximately at 6c€. The total cost varies after the introduction of fines and certified emission reduction cost. These will be dealt later on.

#### **4.1.3. Scenario 3: Fossil Fuel, RE & Hydrogen storage scenario for the transport sector**

This scenario projects a reduction in fossil fuel for transport by introducing hydrogen as a means of energy for transport. A 5% penetration of hydrogen fuel is projected by year 2015. This is further increased to 10% as already shown in Figure 19.

In determining the hydrogen amounts necessary to fulfil the 5% target, a growth rate was worked out using figures extracted from the ten year period 1990-2000 [101]. This growth rate (3.4%) was then applied to the 2003 values, 90 Mlitres of petrol and 90.40 Mlitres of diesel and assuming 0.075 litres of petrol for 1km and 0.07 litres of diesel for 1km thus obtaining estimated travelled kilometres, Figure 18.

The necessary blocks in order to obtain 5% of transport energy from RE are presented in Figure 59. In order to keep the rejected energy within a 10% bracket, fuel cell blocks had to be integrated in the system which would operate when excess hydrogen is produced, provided a security of supply of 240 hours is stored. The 10 day security of supply was chosen so as to balance the need for security and the size of the storage. The net effect of the energy supplied to the grid by the fuel cells is negligible however this was done to minimise the rejected energy. A rejected energy of less than 10% was imperative in the results. Utilising all of this energy is quite impractical when opting for a high level of RE. The blocks of Fuel Cells were chosen such that a minimum operation of 1500 operating hours was achieved. This ensures correct figures in wattage and numbers. Similarly, in choosing the size of blocks it was ensured that adequate period of operation was reached.

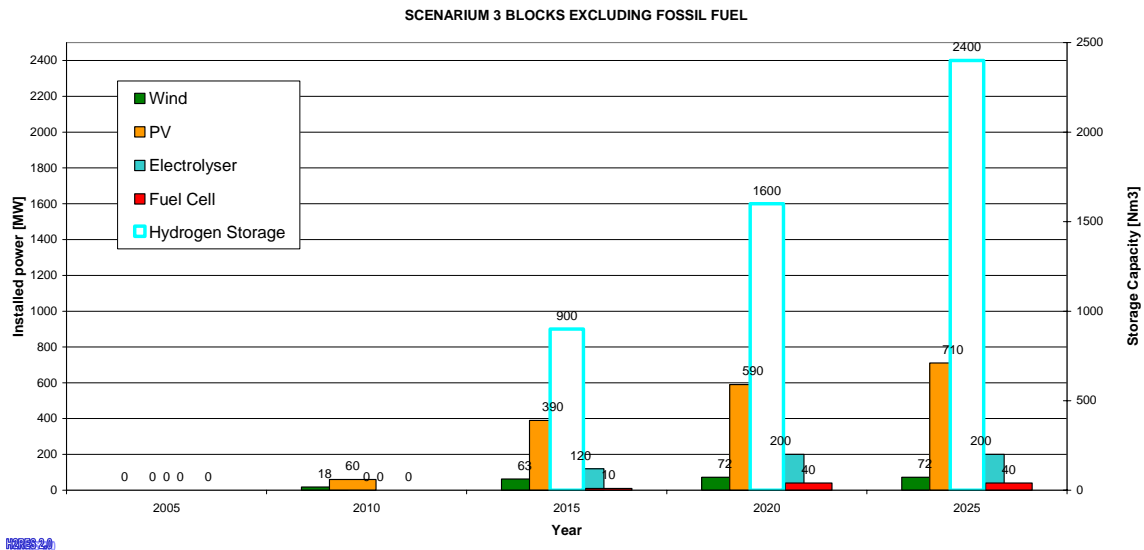

Figure 59: Installed blocks exc. fossil fuel in a scenario 3 according to projected load growth.

Table 29: Scheme of installed fossil fuel blocks according to simulations, 3<sup>rd</sup> scenario.

	FOSSIL FUEL (MW)						TOTAL
	230	120	110	74	37	50	
2005	1	1	1	1	1	0	571
2005-10	1	1	2	1	1	1	731
2010-15	1	1	4	1	1	1	951
2015-20	1	1	6	1	2	2	1,258
2020-25	4	1	6	1	2	2	1,948

Table 30: WT, PV panels, electrolyser, FC and hydrogen storage according to simulations.

	WIND (MW)			PV (m <sup>2</sup> )	Electrolyser	Fuel Cell	Hydrogen Storage (Nm <sup>3</sup> )
	1.8	2	5				
					1000 kW	1000 kW	
2005	0	0	0	0	-	-	-
2005-10	10	0	0	400,000	-	-	-
2010-15	35	0	0	1950,000	120	10	900,000
2015-20	40	0	0	2950,000	200	40	1600,000
2020-25	40	0	0	3550,000	200	40	2400,000

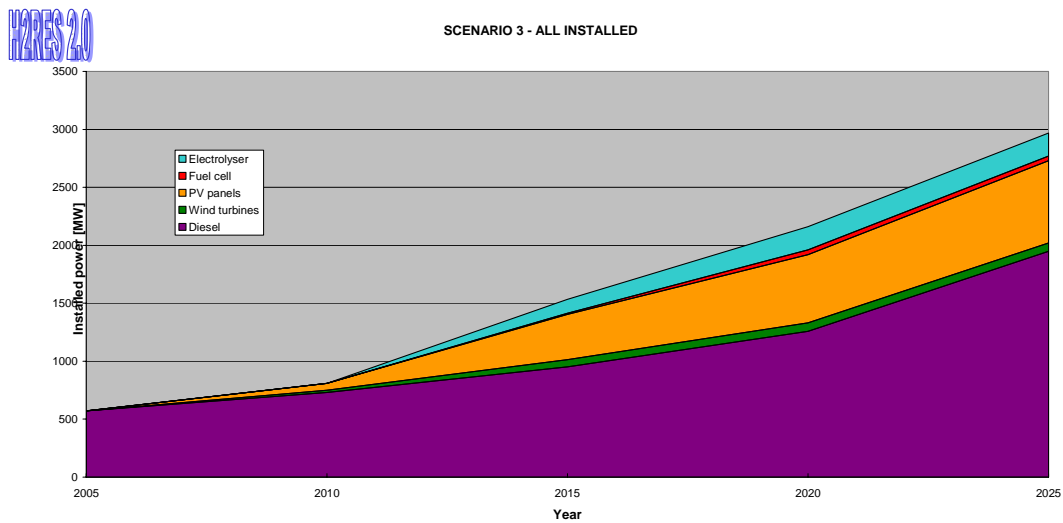

Figure 60: All installed scenario 3.

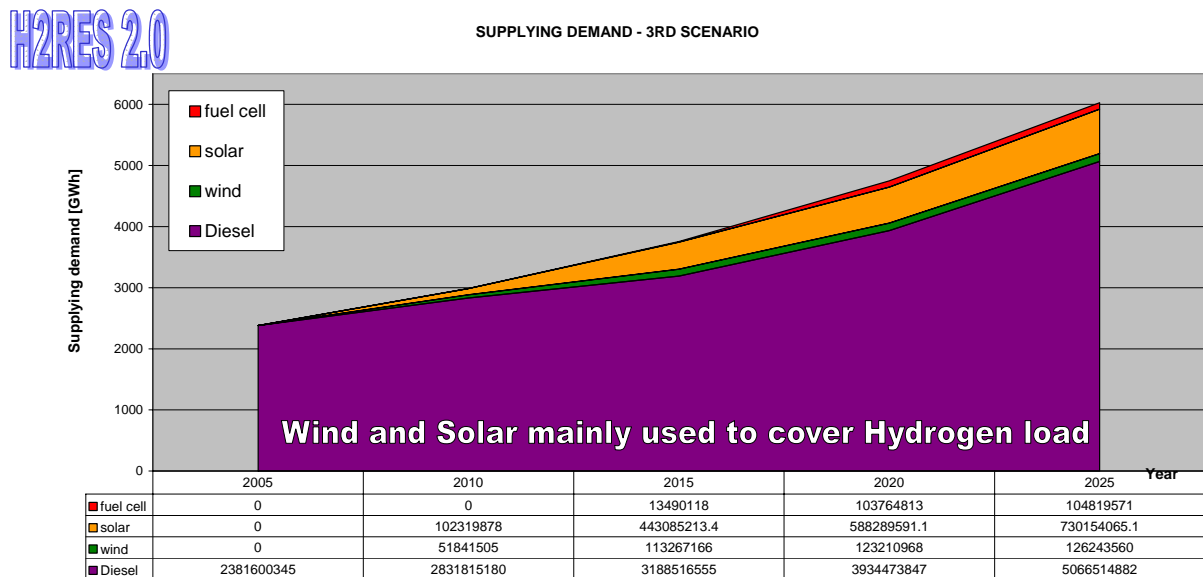

Figure 61: Supplying Demand 3<sup>rd</sup> scenario.

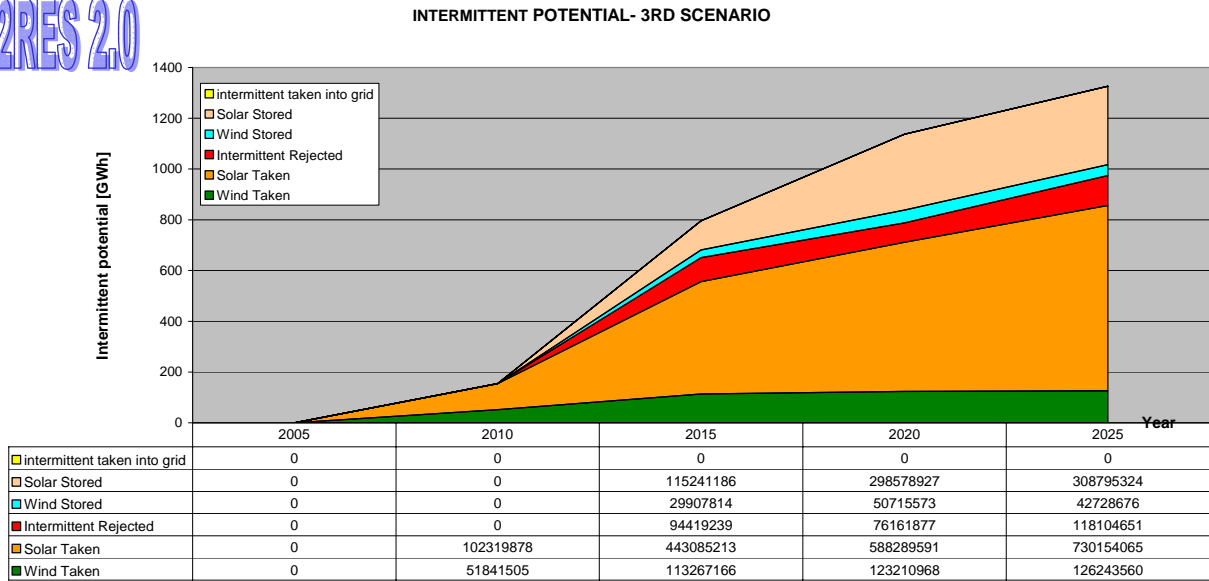

Figure 62: Intermittent potential for scenario 3.

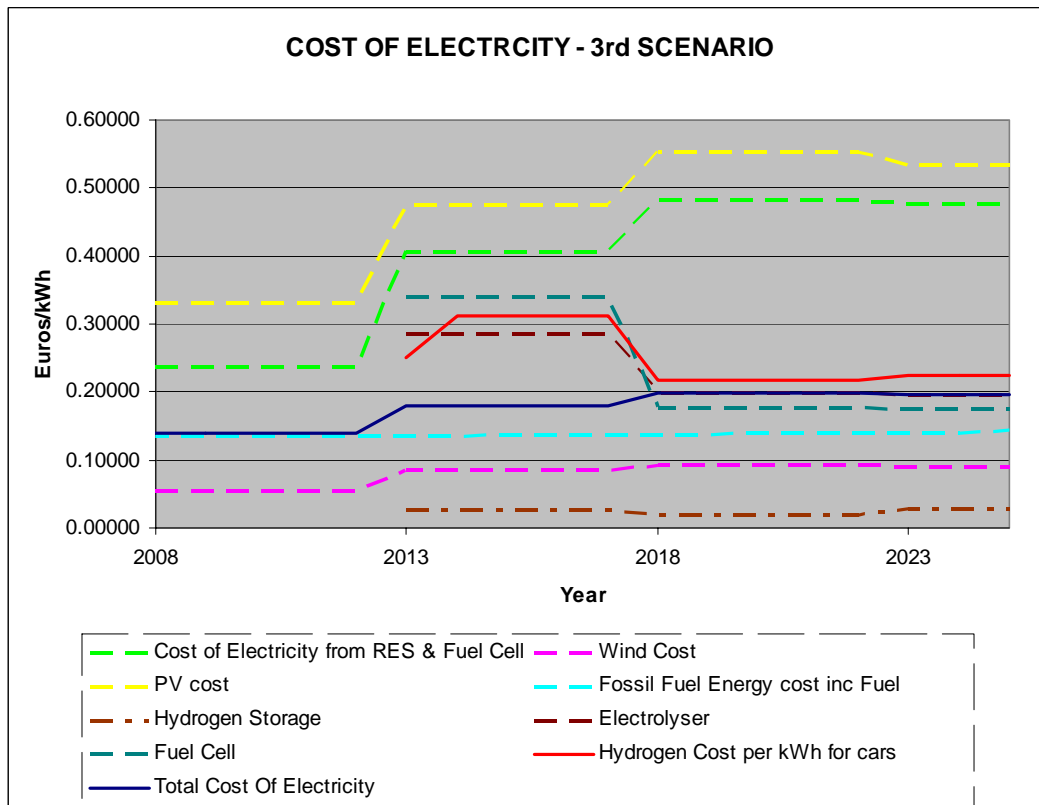

Figure 63: Financial analysis results of third scenario based on projected values.

As previously presented in other scenarios, a break down of costs is necessary in order to be able to understand the technology price contribution to the final price. This scenario involves a lot of

technologies which are also used for different purposes. Figure 63 shows all this. Of particular interest is the final price of hydrogen for transport (Hydrogen Cost per kWh for cars) and the final price of electricity (total cost of electricity). Whilst that at first instance the latter may seem too expensive, the former is cheap. This is similarly tackled by Enemalta (government entity) in current situation, where although electricity price is subsidised, transport fuel is highly taxed. Thus the hydrogen for transport price can be increased whilst that electricity price can be reduced. The balancing of prices is not within the scope of this study and was not analysed. However, this scenario will surely lead to the most expensive prices of all the three scenarios, yet it is a scenario that will save the most emissions thus gaining from EAUs.

## 4.2. Net Present Value

Of particular interest when comparing scenarios is the total present value of all the investment for each scenario analysed. This helps to be able to better compare all the three scenarios against a common base year. In this study, it was decided to levelise all the investments including the fuel to a base year 2005 and then compare all the three investments. Thus, all the yearly investments up to year 2025 were levelised to year 2005 using the following equation:

Equation 15: 
$$PV_{2005} = \sum_{j=1}^n \frac{value_j}{(1 + rate)^j}$$

Where  $PV_{2005}$  = is the PV of all the investments at year 2005 from year 2005 to year 2025

$value_j$  is the yearly payment of installation cost, O&M and fuel at year j

$rate$  is the rate used to obtain the present value, considered to be 6%

$n$  is the total number of years, in this case from year 2005 to year 2025 i.e. 21 years

Investments for periods which coincided outside the 2005-2025 year bracket were not considered in this Present Value evaluation, and should not be considered unless further years are being calculated.



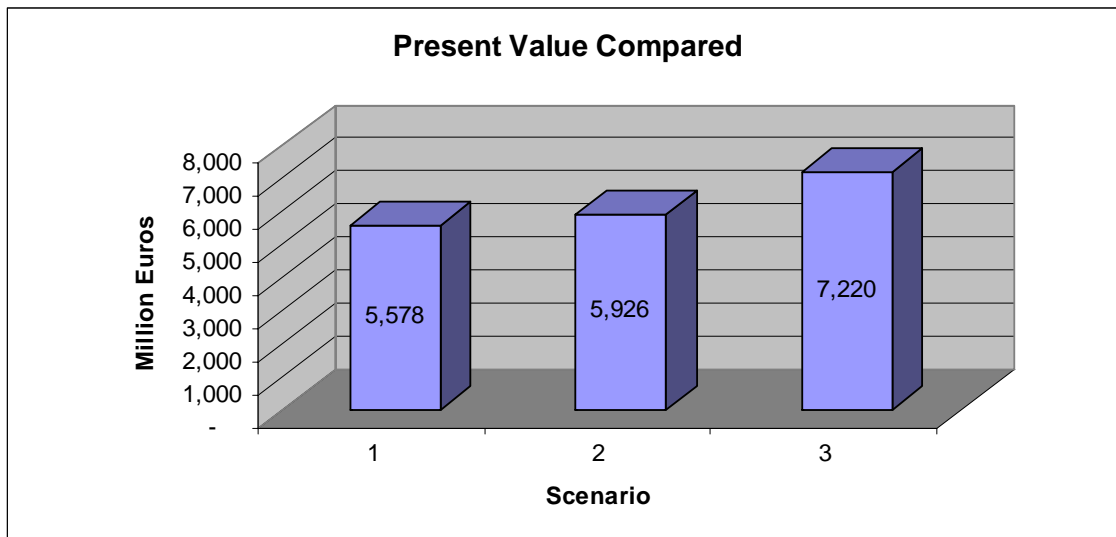

**Figure 64: Present value of all the investments compared as at year 2005**

The total million of Euros for each respective investment as at year 2005 is presented in Figure 64. As expected, Scenario 1 is the least costly, with Scenario 2 following it and finally Scenario 3 being the most expensive. These investments, however, do not take into consideration, the effect of mechanisms regarding CO<sub>2</sub>, thus exclude any external prices. However, it gives an indication that the cost effect of a Scenario 2 is not much more expensive compared to Scenario 1. These prices are tied to a fixed fuel price which is most unlikely to remain so in the next twenty years.

### 4.3. CDM and its effect on electricity

The clean development mechanism and its effects was earlier described in Section 3.10. The following aims to quantify these effects on the energy price if we adopt and if we do not adopt such a scheme. CDM foresees penalties for companies that does not comply with the stipulated targets. These penalties stand at €40/tonne CO<sub>2</sub> in the first trading period (2005-2007) and € 100/tonne CO<sub>2</sub> in the second trading period (2008 -2012). In addition, ETS participants also have to compensate for the missing European trading emission allowance (EAU) in the next period [86]. The limits that Malta is “forced” to follow will typically be 2.024 MtCO<sub>2</sub> for period 2008-2012, followed by 1.892 MtCO<sub>2</sub> for period 2013-2017, 1.76 MtCO<sub>2</sub> for period 2018-2022 and finally 1.42 MtCO<sub>2</sub> for period 2023-2027. These refer to a percentage reduction over the 1990 emitted levels of 8%, 14%, 20% and 30% respectively.

In order to comply with international agreements of Kyoto, CDM mechanisms or emission allowances, Malta has to cover quite a considerable tonnes of CO<sub>2</sub> (refer to Figure 70) which either has to buy as EAU or else pay as fine. The former is cheaper than the latter. The effect on the price

of the choice of such adoption is based on the assumption that a EAU costs 15€ and a fine costs 100€ per tonne of CO<sub>2</sub> emitted (Figure 65). The combination of both will probably lead to an average cost between 40€ and 60€.

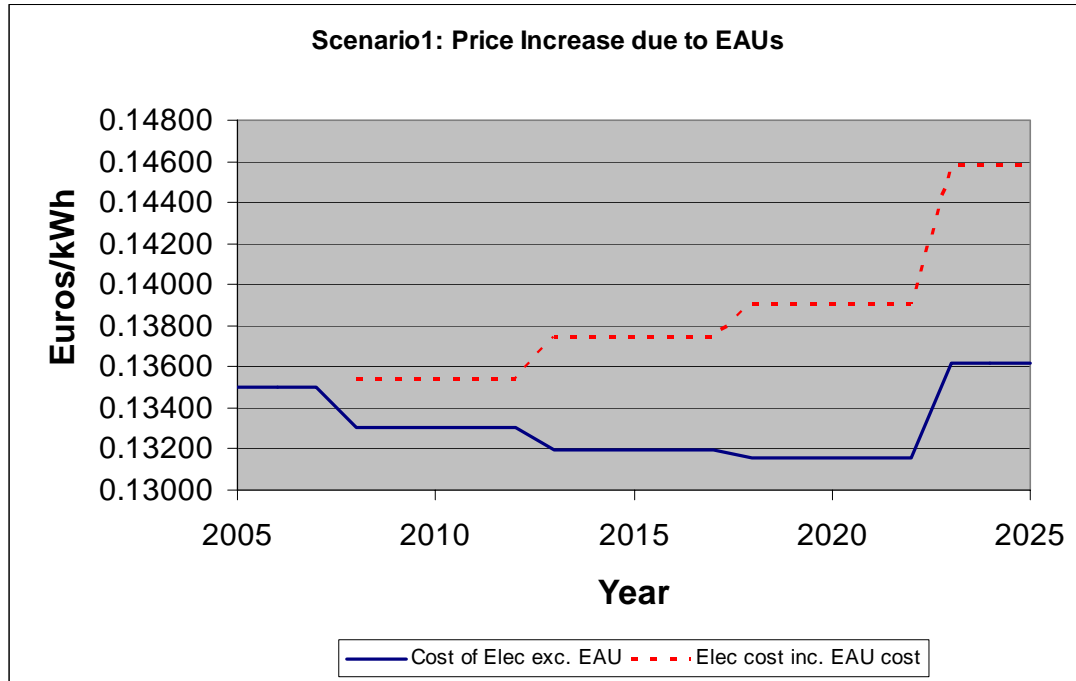

Figure 65: Effect of emission allowances on electricity price scenario 1 at 15€/tCO<sub>2</sub>.

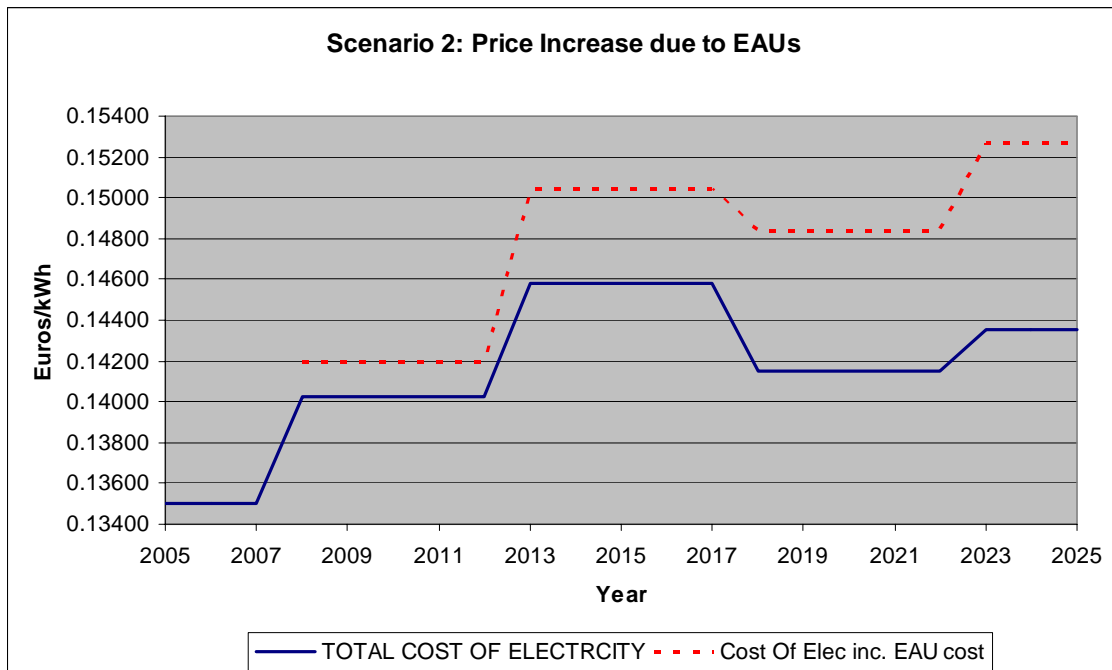
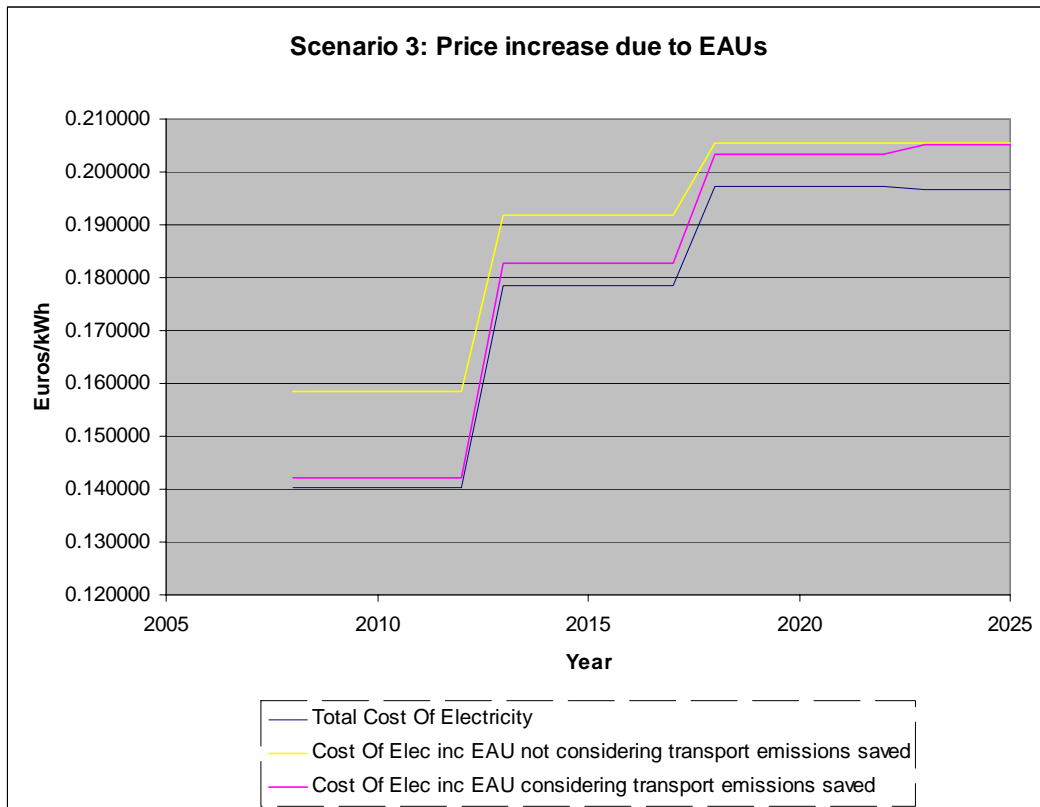

Figure 66: Effect of emission allowances on electricity price scenario 2 at 15€/tCO<sub>2</sub>.



**Figure 67: Effect of emission allowances on electricity price scenario 3 at 15€/tCO<sub>2</sub>.**

Whilst that in the first and second scenario there is a clear difference of what the effect of EAU is on the final price, the difference is less drastic in the third scenario. This is due to the fact that with a 3rd scenario philosophy, the CO<sub>2</sub> emissions are greatly reduced and although the NAP limits are not yet reached, they approach each other considerably. In the 1st scenario (Figure 65), as investment increases, the electricity price without EAU cost decreases (due to increased efficiency of new engines), however, the final cost with EAU increases. Thus the difference between the two increases more and more. In the 2nd scenario (Figure 66), as renewables and load coverage are introduced, the price of electricity increases, however, the electricity cost including EAU cost grows proportionally with this. In the third scenario (Figure 67), the price increase due to EAU is less than in other scenarios especially when considering the CO<sub>2</sub> saved from transport due to hydrogen.

## 5. Conclusion

### 5.1. General Evidences

The results and necessary blocks implementation were presented for each scenario. The introduction of RE in a system has still to be backed up by Fossil Fuel generation in order to secure electrical supply. However, in order for Malta to contribute to the reduction of GHG emissions and global warming, inevitably some RE sources have to be introduced in a particular scenario.

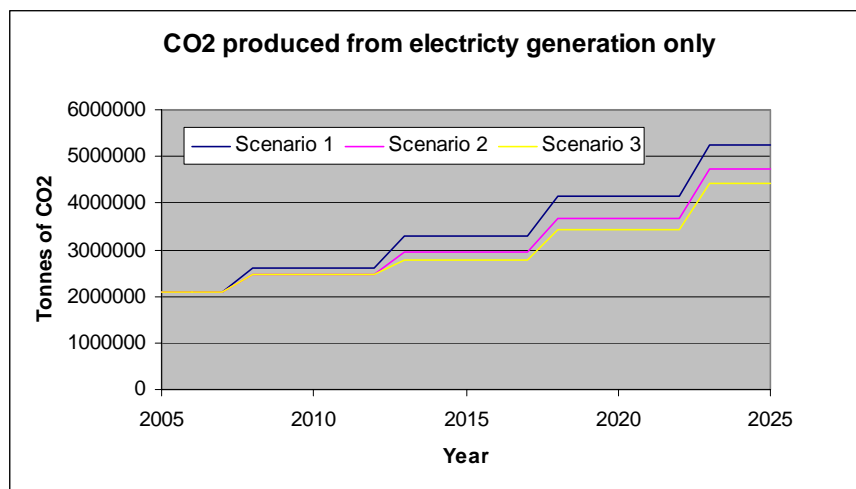

**Figure 68: Produced carbon dioxide from electricity generation only under different scenarios.**

With an average of 0.873 tonnes of carbon dioxide emitted per MWh of electrical energy generated [53], we will be producing approximately 2 Million tonnes of CO<sub>2</sub> in 2005 going up to 5 Million tonnes of CO<sub>2</sub> in 2025 under a BAU scenario 1. The alternatively studied scenarios, project a reduction in this emitted carbon dioxide as shown in Figure 68. However, one has to note that this is due to electricity generation only. Quantifying and adding also the emission reductions utilising hydrogen transport under a Scenario 3 leads to the results shown in Figure 69. This is based on the assumption that an average of 0.20kg of CO<sub>2</sub> is produced for every km travelled by cars.

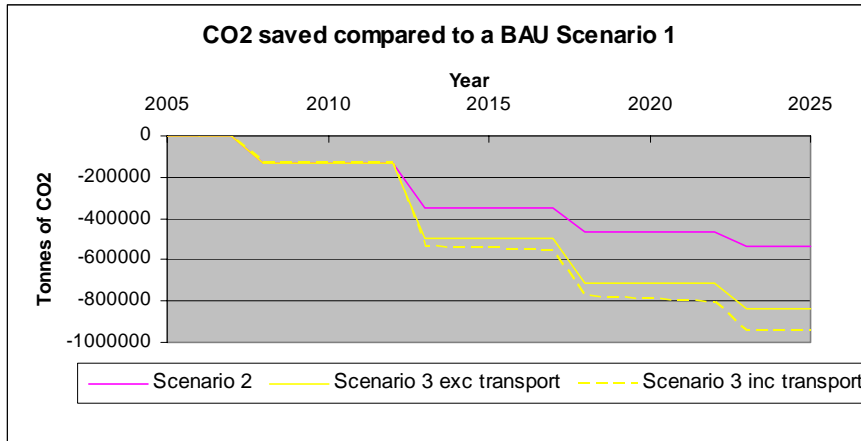

Figure 69: Saved carbon dioxide emission under different scenarios.

The projected produced CO<sub>2</sub> less the allowed to be emitted leads to the results presented in Figure 70. These are the tonnes of CO<sub>2</sub> which Malta has to find a way to cover under the proposed scenarios with the projected load.

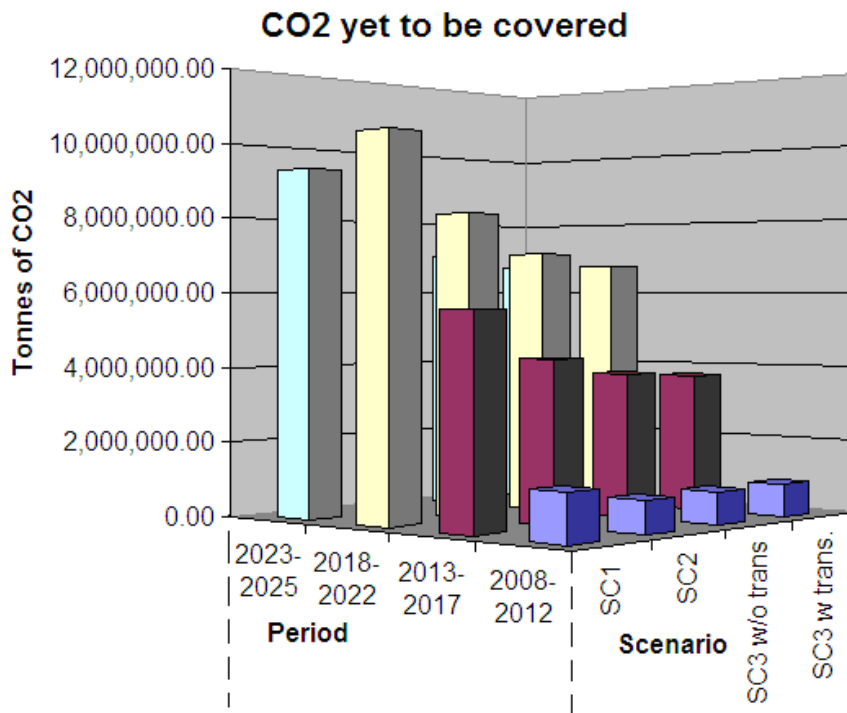

Figure 70: CO<sub>2</sub> to be covered under different scenarios.

An electricity price increase due to the introduction of emission allowances is inevitable in any scenario hereby discussed. With an average price of 15€ per tonne of CO<sub>2</sub> emitted above the NAP limit, a BAU Scenario 1 would bring an average increase in electricity price by about 4.54% until year 2025, followed by a 4.35% for Scenario 2 and finally about 3.12% and 2.17% increase for

Scenario 3 (Figure 71). The suggested scenarios although based to meet the 5% and 10% targets for years 2010 and 2015 electricity from renewables set in the Accession Treaty of EU Directive on the promotion of electricity produced from renewable energy sources fail to cover the CO<sub>2</sub> limits that are being placed on Malta. Introducing more wind turbines or PV cells is not the best possible solution thus the integration of other possibilities is necessary. Demand side management is an obvious must, together with other solutions such as interconnection with the international grid, trapping and energy production from landfill gas and any other similar possibility.

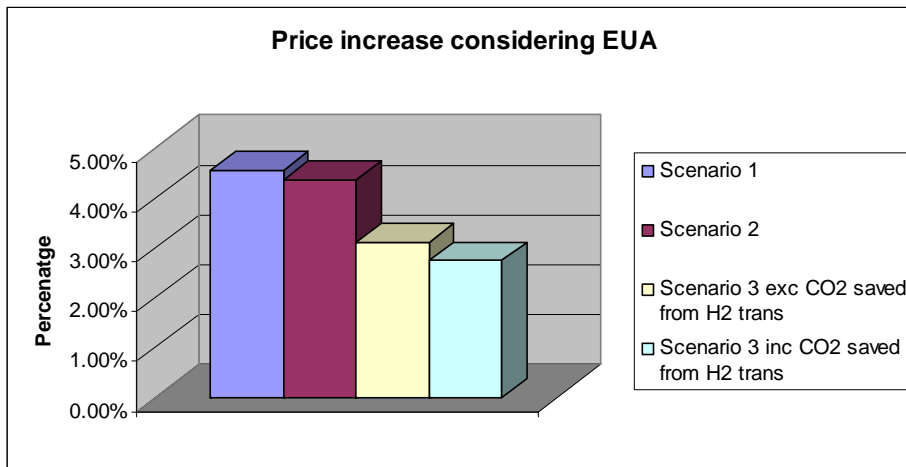

Figure 71: Percentage price increase under different Scenarios at 15€/tCO<sub>2</sub>.

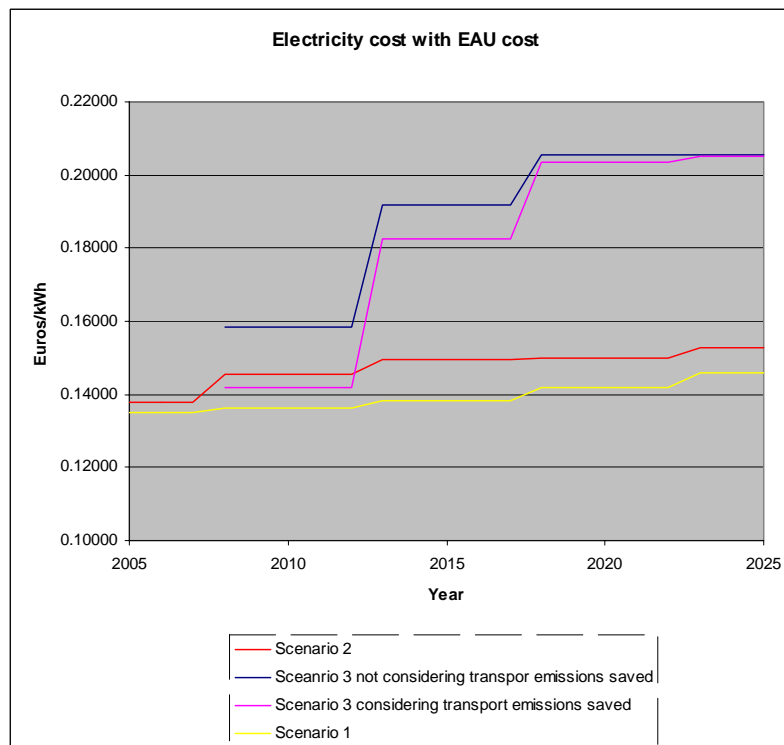

Figure 72: Electricity cost with EAU cost at 15€ per tonne of CO<sub>2</sub> above NAP limit.

The effect of EAU should be carefully analysed. This can lead to decisions in favour or against clean energy technology. Figure 72 shows the final price of all three scenarios including the EAU cost at 15€ per tonne of CO<sub>2</sub> emitted. It is thus obvious that with such a price, money-wise, it is not worth investing in clean energy. However, with a possible increase in this price or lack of these certificates available, the story would take a fold. At this stage, the renewable investment would price-wise be visible. However, it remains a fact that non-redundancy on fossil fuels is always an asset for any country more and more for islands.

## **5.2. How hypothesis was proved**

RE sources in Malta have the potential to leave a remarkable positive effect leading to an economic growth and traditional barriers break down. The economic growth advantages of adopting a green philosophy was similarly tackled and discussed in [91]. The need for an attractive legislative and financing framework is finally considered as the governments' role of promoting the efficient use of energy and the promotion of alternative energy resources. This will reduce fuel imports which are a great drain and a significant constraint on development since this crowd out vital capital and social expenditures and inhibit the achievement of much needed growth. The effect of introducing alternative scenarios with respect to business as usual scenarios was discussed as a function of strict EU awareness and regulations.

## **5.3. Conclusions**

On a European and international level, there are aggressive legislations and future targets for the percentage of RE penetration in the energy mix. In order to obtain these ever increasing targets, the storage of energy as hydrogen is becoming critical especially for the inclusion of intermittent renewable energy in this energy mix. In line with this there has been an ongoing concern and understanding that the collection of data is fundamental in order to monitor what is going on. The UNFCC communication and the National Allocation Plan are two of such reports presenting such important data presentations including data analysis and changes monitoring. Such analysis will eventually lead to foreseen identification of impacts thus guiding in implementing the identified measures and changes at the right time. The financial weight of such measures is usually a determining factor in the functioning of such measures and thus has to be backed and supported through taxes incentives and financial support. Developing countries that perhaps do not have such strategies as their primary concern should be helped and integrated in this global need. On the other hand, leading countries should first of all understand their role in such policy effectiveness and

should also foster and develop new technologies that would eventually help in this beneficial-to-all world strategy.

The proposed scenarios have explored possible paths towards a way of meeting our needs yet considering sustainable ways of achieving this. A business as usual scenario is a scenario which although seems to be the easiest way out of meeting electricity load, will surely suffer some insecurity, lack of dependence and penalties now into effect through European legislations. Although at the moment a high percentage of the load has still to be supplied through fossil fuelled generating blocks (especially for countries lacking nuclear energy), the importance of energy security and diversity is well understood. This leads to current scenario being developed in most countries strengthening their supply through the use of main renewable technologies such as wind and solar. It has to be accepted however that the bulk supply of the base load electricity has still to be supplied by conventional fossil fuel technologies or nuclear energy. Whilst that the acceptance of these varies from place to place, such a scenario is surely a scenario that will eventually lead to a hydrogen era in which the potential of renewables will be maximised.

A hydrogen integrated scenario will surely be the technologically most demanding era. The availability of the technology and the costs are surely the first steps. Then the building up of the infrastructure will be necessary which is likely to be a little different from usual infrastructure build ups. It will be most probably a revolutionary way where a dual approach way will be adopted having both the infrastructure development and a technology-cost bottom up development. The materials science of hydrogen storage is becoming more and more important and although hydrogen processes such as production, storage and conversion has reached a technological level, a lot still remains to be discovered. In line with these studies and discoveries, incentives and regulations have to further encourage this progress. Demonstration of such systems on a small scale such as on islands might prove valuable in order to establish the development of standards and the feasibility of higher RE penetration through hydrogen technology on a larger scale. The success or failure of this era will surely depend on accurate market development analysis. Setting unrealistic and too long-term targets will often lead to disillusionment and abandonment of the technology however failing to introduce this technology at a postponed time will inhibit the growth of such era.

In view of the financial burden that international authorities are placing on the generating entities, one would ask if this would bring an increase in the final price of electricity. Inevitably these costs would either directly or indirectly be passed on to the consumers in the form of higher energy prices which eventually leads to higher prices for goods and services. Such energy cost increase was



estimated to be about “25% wholesale price increase which is equivalent to about 10% end user price increase on a mixed industrial/ commercial/private sales portfolio” for the period up to 2015 with an average of 15€/tonne [92]. Similarly for a study done in Italy, it was estimated to be about 13% for the 2008-2012 period [93]. This percentage is expected to be less high in Malta as shown in Figure 71. This will reduce the purchasing power of the consumers thus also effecting the economy. Employment losses and job requests will also change due to a change in traditional energy thinking way. This price increase will have an impact on energy consumption in all sectors.

In the **domestic sector** the radically higher energy prices would, on the short term, oblige the domestic consumers to reduce their electricity consumption. On the long term, consumers would attempt to utilise energy saving equipment such as solar heaters and better class equipment.

The **industry sector** is expected to answer through different ways. Inevitably, a reduction in energy consumption is the first process. Then, replacing old energy consuming machinery with more efficient ones and the third process being that of moving and opening factories in places where these energy measures are less stringent or not applicable.

The **power sector** has no other way other than that to think “clean and efficient”. The ever increasing stringent rules will force generating utilities to invest in renewable and clean energy either locally or abroad. The investment for the transition from carbon fuel to cleaner carbon fuel such as gas will become a necessity. Coal use would thus decline, slowly at first and then rapidly. Investment in natural gas fired generating capacity would alleviate some of the pressure on electricity prices, however, efficiency in production and distribution would still be a necessity since a small percentage gain in efficiency would imply very huge savings.

The influence of these measures is expected to be less influencing in the **transportation sector** for the main reason that due to the high taxes already in place on transportation fuels, the percentage change in price due to the addition of the carbon permit fees is less than the change in price in other sectors. On a longer term, more taxes would be introduced or else taxes will be differently allocated in order to encourage alternative transport means or more cautious use.

Changes in electricity prices will not be a consequence of emissions trading, but of implementation of the Kyoto Protocol. Kyoto protocol is thus a burden to be shared by all however to the benefit of all. The Kyoto Protocol sets a cap on allowable greenhouse gas emissions, which means that the EU economy will be a carbon constrained economy in the future. This carbon constraint gives value to the allowances and leads to changes in relative prices in the EU economy. Goods that contain more

carbon will be relatively more expensive than goods that contain less carbon. On the other hand however, Kyoto flexible mechanisms such as CDM could increase the feasibility of renewable energy projects by providing an extra revenue stream to counter these financial barriers.

In energy terms, Malta's current energy economy is unsustainable because being based on fossil fuelled blocks, having not yet discovered natural deposits and relying entirely on fossil fuel provisions supplied by other countries leads the country to a very limited control on its economic destiny since its energy expenditure is determined by others and it has no power in influencing such prices. However, the introduction of other sources will incubate sustainability. The main governmental authorities and companies such as the Malta Resources Authority (MRA), the Malta Environment and Planning Authority (MEPA), and Enemalta Corporation will surely be key players in attributing to a success or failure of proposed scenarios in Malta. Direct and indirect incentives for this introduction have to be effected maturely without any bureaucratic actions at all levels, from which both the private and the government sector will eventually benefit.

The barriers to adhere to the expected results has been presented. Investing in the generating utility is not enough to meet the expectations. A consumer investment, either from the government or from the consumer itself is also necessary. The further help from the government to introduce solar water heaters for 50% of households (70,000) can lead to 90,000 EAUs/ year [94]. Energy saving measures in high energy consuming plants such as reverse osmosis and the utilisation of Agricultural waste treatment and landfill gas will also lead to a reduction in CO<sub>2</sub> or more EAUs gained. Only by a combination of all efforts can we make it to meet our targets.

## References

- [1] <http://webapps01.un.org/dsd/partnerships/public/partnerships/158.html>
- [2] Neven Duic, Luis Manuel Alves, Maria da Graca Carvalho Fengzhen Chen, Renewislands- Renewable energy solutions for islands, available on [www.sciencedirect.com](http://www.sciencedirect.com)
- [3] Uemura Y, Kai T, Natori R, Takahashi T, Hatate Y, Yoshida M. Potential of renewable energy sources and its applications in Yakushima Island. *Renew Energy* 2003;29:581–91.
- [4] Chen F, Lerer M, Alves LM, Carvalho MG. The development status of renewable hydrogen supplied for islands. In: Proceedings of the international conference on new and renewable energy technologies for sustainable development, E' vora, Portugal, 28 June–1 July 2004.
- [5] N.Zouros, G.C. Contaxisa, J.Kabouris, Decision support tool to evaluate alternative policies regulating wind integration into autonomous energy systems; *Energy Policy* 33 (2005) 1541–1555
- [6] Scott Kennedy, Wind power planning: assessing long-term costs and benefits, *Energy Policy* 33 (2005) 1661–1675
- [7] Harald Miland, Operational Experience and Control Strategies for a Stand-Alone Power System based on Renewable Energy and Hydrogen, February 2005, Norwegian University of Science and Technology , Faculty of Natural Sciences and Technology, Department of Materials Technology
- [8] <http://www.freepatentsonline.com/7118606.html>
- [9] <http://www.washingtonpost.com/ac2/wp-dyn?pagename=article&node=&contentId=A3445-2002Sep25&notFound=true>
- [10] Bockris JO'M. The origin of ideas on a hydrogen economy and its solution to the decay of the environment. *Int J Hydrogen Energy* 2002;27:731–40.
- [11] W.C. Lattina, V.P. Utgikarb, Transition to hydrogen economy in the United States: A status report, *International Journal of Hydrogen Energy* 32 (2007) 3230 – 3237
- [12] European Commission, Towards a Hydrogen era, available on: [http://ec.europa.eu/research/leaflets/h2/page\\_104\\_en.html](http://ec.europa.eu/research/leaflets/h2/page_104_en.html)
- [13] European commission, Hydrogen Energy and Fuel Cells, A vision of our future, 2003 available on: [http://ec.europa.eu/research/energy/pdf/hlg\\_vision\\_report\\_en.pdf](http://ec.europa.eu/research/energy/pdf/hlg_vision_report_en.pdf)
- [14] V.A. Goltsov, T.N. Veziroglu and L.F. Goltsova; Hydrogen civilization of the future - A new conception of the IAHE, *International Journal of Hydrogen Energy*, Volume 31, Issue 2, February 2006, Pages 153-159.
- [15] <http://www.interesting.vaty.net/2006/10/high-hopes-for-hydrogen.html>
- [16] B.S. Richards, G.J. Conibeer, A comparison of hydrogen storage technologies for solar-

- powered stand-alone power supplies: A photovoltaic system sizing approach.- International Journal of Hydrogen Energy, Volume 32, Issue 14, September 2007.
- [17] R. Gazeya, S.K. Salman, Aklil-D'Halluin: A field application experience of integrating hydrogen technology with wind power in a remote island location. Journal of Power Sources, Volume 157, Issue 2, 3 July 2006, Pages 841-847.
- [18] John O'M. Bockrisa,, T. Nejat Veziroglu, Estimates of the price of hydrogen as a medium for wind and solar sources. International Journal of Hydrogen Energy, Volume 32, Issue 12, August 2007, Pages 1605-1610
- [19] European Commission , Alternative fuels for Transport, April 2005 available on : <http://www.euractiv.com/en/environment/alternative-fuels-transport/article-138101>
- [20] E. Tzimas, P. Castello, S. Peteves, The evolution of size and cost of a hydrogen delivery infrastructure in Europe in the medium and long term, International Journal of Hydrogen Energy 32 (2007) 1369 – 1380 available on [www.elsevier.com/locate/ijhydene](http://www.elsevier.com/locate/ijhydene).
- [21] Harvard Family Research, Detangling data collection-Methods for gathering data, August 2004 available on:  
[www.gse.harvard.edu/hfrp/content/projects/afterschool/resources/snapshot5.pdf](http://www.gse.harvard.edu/hfrp/content/projects/afterschool/resources/snapshot5.pdf)
- [22] <http://www.gsfc.nasa.gov/gsfc/images/earth/avhrr/seatemp.gif>
- [23] Zouros, N., 2003. Impact evaluation by the wind power integration into autonomous electric systems.Ph. D. Dissertation, National Technical University of Athens, Department of Electrical and Computer Engineering, Electrical Power Systems Laboratory (in Greek).
- [24] [http://en.wikipedia.org/wiki/Wind\\_power](http://en.wikipedia.org/wiki/Wind_power)
- [25] World Wind Energy Association, New World record in Wind Power capacity, 2007 available on: [www.wwindea.org/home/images/stories/pdfs/pr\\_statistics2006\\_290107.pdf](http://www.wwindea.org/home/images/stories/pdfs/pr_statistics2006_290107.pdf)
- [26] [http://www.ecoworld.org/articles/images/UKWind\\_Wind%20Turbines%20in%20Water%20\(Sandia%20US%20Gov\).jpg](http://www.ecoworld.org/articles/images/UKWind_Wind%20Turbines%20in%20Water%20(Sandia%20US%20Gov).jpg)
- [27] <http://www.edn.com/article/CA6432171.html>
- [28] <http://209.85.135.104/search?q=cache:N3fokDvAQgJ:www.maltaculture.com/page.asp%3Fp%3D3806%26l%3D1+built+up+area+of+malta&hl=it&ct=clnk&cd=10&gl=it>
- [29] Shimon Awerbuch, Investing in photovoltaics: risk, accounting and the value of new technology, Energy Policy 28 (2000) 1023}1035
- [30] <http://fuelcellworks.com/Typesoffuelcells.html>
- [31] IEA, Hydrogen Supply options, March 2003 available on:  
<http://www.iea.org/Textbase/work/2003/hydrogen/sessionii/Fossil%20Fuels.pdf>

- [32] IEA, IEA Energy Technology Essentials, Hydrogen Production and distribution, April 2007 available on : <http://www.iea.org/Textbase/techno/essentials5.pdf>
- [33] IEA, Hydrogen Production and storage- R&D priorities and gaps, 2006 available on: <http://www.iea.org/textbase/papers/2006/hydrogen.pdf>
- [34] Andreas Züttel, Materials for Hydrogen Storage, September 2003, available on: <http://www.ifres.ch/Homepage/DB/Paper4.pdf>
- [35] Dr. T Clemens, A Hydrogen Economy for New Zealand, October 2005, available on: <http://www.crl.co.nz/publications/Hydrogen%20research/EFNZ%20Hydrogen%20Oct%2012%202005.pdf>
- [36] Trygve Riis, Elisabet F. Hagen, Preben J. S. Vie, Øystein Ulleberg, Hydrogen Production - Gaps and Priorities, 2005 available on: [http://www.ieahia.org/pdfs/HIA\\_Production\\_G&P\\_Final\\_with\\_Rev.pdf](http://www.ieahia.org/pdfs/HIA_Production_G&P_Final_with_Rev.pdf)
- [37] Duić N., Krajačić G., Carvalho M.G., RenewIslands methodology for sustainable energy and resource planning for islands, Renewable and Sustainable Energy Reviews, 2007, Article in press
- [38] Henrik Lunda, Neven Duić, Goran Krajacic, Maria da Graça Carvalho, Two energy system analysis models: A comparison of methodologies and results; available on [www.sciencedirect.com](http://www.sciencedirect.com).
- [39] Bürer, Meinrad; Foradini, Flavio; Bauen, Ausilio; Duić, Neven; Lerer, Maria; Fonseca, Jose Pedro; Alves, Luis; Carvalho, Maria da Graça; Nakken, Torgeir; Hansen, Anne Marit; Gonzales, Penelope Ramirez; Marrero, Augustin; Suarez, Salvador; Oliveira, Filipe; Henriques, Claudia; Psarras, John; Zevgolis, Dimitris; Coroyannakis, Panos, Description of system configurations and model design, results and analysis for selected integrated RES/H<sub>2</sub> systems and H<sub>2</sub> end-uses, Deliverable 2 RenewIslands project, 366 pp., 2005.
- [40] Milborrow, 2001, Milborrow, 2002, Stavrakakis, 2000, Altmann et al, 2000, Putnam, 1996, EEM and Jensen, 1998.
- [41] Shimon Awerbuch, Investing in Photovoltaics: risk, accounting and the value of the new technology, Energy Policy 28 (2000) 1023-1035.
- [42] Shimon Awerbuch, Estimating Electricity Generating Costs: A CAPM Approach, May 2006 available on: [http://www.awerbuch.com/shimonpages/shimondocs/Manu\\_chap\\_1.pdf](http://www.awerbuch.com/shimonpages/shimondocs/Manu_chap_1.pdf)
- [43] Article 2. The United Nations Framework Convention on Climate Change. Retrieved on November 15, 2005

- [44] Joint CIS EPC/EURELECTRIC Group "Environment" CIS ELECTRIC, Key Environmental Protection Issues of the EU and CIS Power Market Integration, November 2005 available on: [www.eurelectric.org/Download/Download.aspx?DocumentID=18843](http://www.eurelectric.org/Download/Download.aspx?DocumentID=18843)
- [45] <http://www.cia.gov/cia/publications/factbook/geos/mt.html>
- [46] Government of Malta, The First Communication of Malta to the United Nations Framework Convention Climate Change, 2004 available on:  
[http://unfccc.int/resource/docs/natc/mlt\\_nc01.pdf](http://unfccc.int/resource/docs/natc/mlt_nc01.pdf)
- [47] [www.nso.gov.mt](http://www.nso.gov.mt)
- [48] Andrew Warren, Directive should be greatest step change in energy buildings, Energy in Buildings & Industry – July/August 2002 available on  
[http://www.euroace.org/articles/A\\_010702.pdf](http://www.euroace.org/articles/A_010702.pdf)
- [49] Caroline Caruana B.E. & A. (Hons.), A. & C.E., The Energy Intensity of Office/Showroom Buildings, An Analytical Approach, Faculty of Architecture & Civil Engineering, University of Malta, June 2000, available on:  
[www.bicc.gov.mt/bicc/files\\_folder/Caroline%20Caruana.pdf](http://www.bicc.gov.mt/bicc/files_folder/Caroline%20Caruana.pdf)
- [50] Service Division, Building Regulations Office, Malta, Technical Guidance, Conservation of Fuel, Energy and Natural Resources (minimum requirements on the energy performance of building regulations, 2006) available on:  
[www.bicc.gov.mt/bicc/files\\_folder/Cons%20Fuel%20Energy%20Doc%20F%20new.pdf](http://www.bicc.gov.mt/bicc/files_folder/Cons%20Fuel%20Energy%20Doc%20F%20new.pdf)
- [51] [http://www.mra.org.mt/energy\\_legislation.shtml](http://www.mra.org.mt/energy_legislation.shtml)
- [52] <http://www.enemalta.com.mt/page.asp?p=926&l=1>
- [53] Government of Malta, National Allocation plan for Malta 2005-2007, October 2004, available on: <http://ec.europa.eu/environment/climat/pdf/malta.pdf>
- [54] National Statistics Office, Electricity Generation in Malta, available on :  
[http://www.nso.gov.mt/statdoc/document\\_view.aspx?id=2064&backurl=/themes/theme\\_page.aspx](http://www.nso.gov.mt/statdoc/document_view.aspx?id=2064&backurl=/themes/theme_page.aspx), December 2007.
- [55] European Environmental Agency, TERM 2003 01 AC + CC — Transport final energy consumption by mode, 2003 available on:  
[http://themes.eea.europa.eu/Sectors\\_and\\_activities/transport/indicators/consequences/TERM\\_01,2003/TERM\\_2003\\_01\\_ACCC.pdf](http://themes.eea.europa.eu/Sectors_and_activities/transport/indicators/consequences/TERM_01,2003/TERM_2003_01_ACCC.pdf)
- [56] Ministry for Resources and Infrastructure, Report on the application of Directive 2003/30/EC (promotion of the use of biofuels or other renewable fuels for transport) September 2004, available on:

- [http://ec.europa.eu/energy/res/legislation/doc/biofuels/member\\_states/2003\\_30\\_mt\\_report\\_en.pdf](http://ec.europa.eu/energy/res/legislation/doc/biofuels/member_states/2003_30_mt_report_en.pdf)
- [57] <http://www.enemalta.com.mt/page.asp?p=995>
- [58] Eurostat, Electricity prices in the EU25 in January 2006, July 2006 available on: [http://epp.eurostat.ec.europa.eu/pls/portal/docs/PAGE/PGP\\_PRD\\_CAT\\_PREREL/PGE\\_CATT\\_PREREL\\_YEAR\\_2006/PGE\\_CAT\\_PREREL\\_YEAR\\_2006\\_MONTH\\_07/8-14072006-EN-AP1.PDF](http://epp.eurostat.ec.europa.eu/pls/portal/docs/PAGE/PGP_PRD_CAT_PREREL/PGE_CATT_PREREL_YEAR_2006/PGE_CAT_PREREL_YEAR_2006_MONTH_07/8-14072006-EN-AP1.PDF)
- [59] [http://www.victorborg.com/html/features\\_\\_articles.html](http://www.victorborg.com/html/features__articles.html)
- [60] Enemalta Corporation, Electricity Generation plan 2006-2015, available on: <http://www.miti.gov.mt/docs/Enemalta%20Generation%20Plan%20June%202006.pdf>
- [61] Freris, L. L. (ed.), Wind Energy Conversion Systems, Prentice Hall International Ltd., Hemel Hempstead (UK), 1990.
- [62] [www.maltaweather.com](http://www.maltaweather.com)
- [63] <http://www.windatlas.dk/Europe/oceanmap.html>
- [64] Scott Wilson report, Malta Significant wave height study, December 2003 available on: [http://www.mma.gov.mt/pics/maltarepot\\_final\\_flags.pdf](http://www.mma.gov.mt/pics/maltarepot_final_flags.pdf)
- [65] <http://www.mepa.org.mt/asps/agenda.asp?agendadate=2005/5/11>
- [66] Antoine Riolo, CEO, MRA, Sites for Offshore Windfarm Development, Their Potential and Constraints, Renewable Energies and Beyond Presentation 2005
- [67] <http://www.ljrenewableenergy.info/whysolarpower.html>
- [68] Marcel Suri, Thomas A. Huld, Ewan D. Dunlop, REGIONAL DIFFERENCES OF THE PV ELECTRICITY PRODUCTION IN EU25 COUNTRIES, June 2004 available on: [http://re.jrc.cec.eu.int/pvgis/doc/paper/2004-eupvsec\\_suri-huld-dunlop\\_paper.pdf](http://re.jrc.cec.eu.int/pvgis/doc/paper/2004-eupvsec_suri-huld-dunlop_paper.pdf)
- [69] Akiwale A., Solar Radiation over Malta, M.Sc. dissertation, Centre for Renewable Energy Systems Technology (CREST), Loughborough University, UK, in collaboration with the Institute for Energy Technology, University of Malta, Malta. (2003)
- [70] <http://re.jrc.ec.europa.eu/pvgis/apps/radmonth.php?lang=en&map=africa>
- [71] Charles Yousif, Contribution of Solar Applications Towards Achieving a Renewable Energy Target For Malta. Institute for Energy Technology, University of Malta (2005)
- [72] <http://home.um.edu.mt/ietmalta/postgraduate.htm>
- [73] J.Mangion, M.Sapiano, Meeting the Demand – Enhancing the Availability of Water Supplies in Malta, Feb 2005 available on: [http://www.cyprus.gov.cy/moa/wdd/WDD.nsf/All/6CE223A01F3FE75AC2256FA4004E7204/\\$file/13.15%20Mangion%20both.pdf](http://www.cyprus.gov.cy/moa/wdd/WDD.nsf/All/6CE223A01F3FE75AC2256FA4004E7204/$file/13.15%20Mangion%20both.pdf)

- [74] [http://209.85.135.104/search?q=cache:Drp-UQyCl1MJ:www.esru.strath.ac.uk/EandE/Web\\_sites/98-9/offshore/h2.htm+electrolysis+of+seawater&hl=it&ct=clnk&cd=1&gl=it](http://209.85.135.104/search?q=cache:Drp-UQyCl1MJ:www.esru.strath.ac.uk/EandE/Web_sites/98-9/offshore/h2.htm+electrolysis+of+seawater&hl=it&ct=clnk&cd=1&gl=it)
- [75] <http://www.aie.org.au/melb/material/resource/pwr-eff.htm>
- [76] Edward S. Rubin, Chao Chen, Anand B. Rao, Cost and performance of fossil fuel power plants with CO<sub>2</sub> capture and storage, *Energy Policy* 35 (2007) available on: <http://www.iecm-online.com/PDF%20Files/Rubin%20Chao%20Energy%20Policy%20Sep%202007.pdf>
- [77] <http://www.opec.org/home/basket.aspx>
- [78] Ministry for Investment and Technology, Fuel Price Revision, July 2005, available on: <http://www.miti.gov.mt/site/page.aspx?pageid=672>
- [79] Sébastien Soleille, Greenhouse gas emission trading schemes: a new tool for the environmental regulator's kit, *Energy Policy*, Volume 34, Issue 13, September 2006, Pages 1473-1477
- [80] N. Duic, L.M. Alves, F. Chen, M. da Graca Carvalho, Potential of Kyoto Protocol Clean Development Mechanism in transfer of clean energy technologies to Small Island Developing States: case study of Cape Verde, Research Group on Energy and Sustainable Development, Instituto Superior Tecnico, Lisbon, Portugal, October 2002 available on: [www.sciencedirect.com](http://www.sciencedirect.com)
- [81] Halsnaes K., Market potential for Kyoto mechanisms - estimation of global market potential for cooperative greenhouse gas emission reduction policies. *Energy Policy* 2002;30(1):13–32.
- [82] Jepma CJ, Gaast W. On the potential of flexible instruments under the Kyoto Protocol. *International Journal of Environment and Pollution* 1998;10(3-4):476–84.
- [83] Philibert C. How could emissions trading benefit developing countries. *Energy Policy* 2000;28(13):947–56.
- [84] John Balint, Setting up a National Strategy for CDM, April 2007, available on: [http://www.mcst.org.mt/files/uploaded/Balint\\_MaltaCDMStrategyPresentation-April202007.pdf](http://www.mcst.org.mt/files/uploaded/Balint_MaltaCDMStrategyPresentation-April202007.pdf)
- [85] Government of Malta, EU Emissions Trading Scheme Directive 2003/87/EC NATIONAL ALLOCATION PLAN FOR MALTA 2008 – 2012, available on: [http://ec.europa.eu/environment/climat/pdf/nap\\_malta\\_final.pdf](http://ec.europa.eu/environment/climat/pdf/nap_malta_final.pdf)
- [86] Dti, Carbon Prices - A Climate Change Projects Office Guide, available on: [www.berr.gov.uk/files/file21144.pdf](http://www.berr.gov.uk/files/file21144.pdf)



- [87] European Commission, Questions and Answers on Emissions Trading and National Allocation Plans for 2008 to 2012, November 2006 available on: [http://ec.europa.eu/environment/climat/pdf/m06\\_452\\_en.pdf](http://ec.europa.eu/environment/climat/pdf/m06_452_en.pdf)
- [88] <http://www.guardian.co.uk/environment/2007/feb/21/climatechange.climatechangeenvironm>  
ent
- [89] [http://hdrstats.undp.org/countries/country\\_fact\\_sheets/cty\\_fs\\_MLT.html](http://hdrstats.undp.org/countries/country_fact_sheets/cty_fs_MLT.html)
- [90] <http://europa.eu/rapid/pressReleasesAction.do?reference=IP/06/1650&format=HTML&aged=1&language=EN&guiLanguage=fr>
- [91] Lund H. A green energy plan for Denmark—job creation as a strategy to implement both economic growth and a CO<sub>2</sub> reduction. *Environ Resour Econ* 1999;14(3):431–9.
- [92] Per Lekander, McKinsey, Impact of ETS on power prices, CEPS-workshop, December 13, 2003 available on: [ceps01.link.be/files/TF/LekanderMcKinsey161203.ppt](http://ceps01.link.be/files/TF/LekanderMcKinsey161203.ppt)
- [93] ICCF, Kyoto Protocol and Beyond,: The Economic cost to Italy , 2005 available on: [www.iccfglobal.org/pdf/Italyfinal101705.pdf](http://www.iccfglobal.org/pdf/Italyfinal101705.pdf)
- [94] Ing M. Cremona, Clean Development Mechanism workshop, April 2007 available on: [www.mcst.org.mt/files/uploaded/PotentialCDMinMalta\\_MarcoCremona.pdf](http://www.mcst.org.mt/files/uploaded/PotentialCDMinMalta_MarcoCremona.pdf)
- [95] <http://www.oregon.gov/ENERGY/RENEW/costs.shtml#Levelized%20life-cycle%20cost>
- [96] B.S. Richardsa, G.J. Conibeerb, A comparison of hydrogen storage technologies for solar-powered stand-alone power supplies: A photovoltaic system sizing approach, *International Journal of Hydrogen Energy* 32 (2007) 2712 – 2718, [www.elsevier.com/locate/ijhydene](http://www.elsevier.com/locate/ijhydene)
- [97] European Commission, RENEWABLE SOURCES OF ENERGY, White Paper for a Community Strategy and Action Plan, November 1997 available on: [http://ec.europa.eu/energy/library/599fi\\_en.pdf](http://ec.europa.eu/energy/library/599fi_en.pdf)
- [98] Charles Yousif, Contribution of Solar Applications Towards Achieving a Renewable Energy Target For Malta. Institute for Energy Technology, University of Malta. (2005)
- [99] <http://thewatt.com/modules.php?name=News&file=article&mode=nested&sid=915>; visited May 2005
- [100] A Draft Renewable Energy Policy for Malta, August 2006, available on: <http://www.doi.gov.mt/EN/archive/prebudget2007/Renewable%20Energy.pdf>
- [101] European Environment Agency, Transport final energy consumption by mode, Indicator fact sheet, TERM 2002 01 AC, available on: [http://themes.eea.europa.eu/Sectors\\_and\\_activities/transport/indicators/consequences/TERM\\_01,2002/TERM\\_2002\\_01\\_AC\\_Energy\\_consumption.pdf](http://themes.eea.europa.eu/Sectors_and_activities/transport/indicators/consequences/TERM_01,2002/TERM_2002_01_AC_Energy_consumption.pdf)
- [102] [http://www.mra.org.mt/energy\\_legislation.shtml](http://www.mra.org.mt/energy_legislation.shtml)

- [103] J Painuly, Economic and Financial Feasibility of Wind Energy - Case Study of Philippines available on: [http://www.risoe.dk/rispubl/reports/ris-r-1608\\_150-159.pdf](http://www.risoe.dk/rispubl/reports/ris-r-1608_150-159.pdf)
- [104] European Commission Enterprise and Industry, Facing the Future, March 2005 available on [http://209.85.135.104/search?q=cache:zRNh4IL9jccJ:ec.europa.eu/enterprise/library/enterpriseurope/issue18/articles/en/topic2\\_en.htm+european+cost+of+pv+panels&hl=it&ct=clnk&cd=3&gl=it](http://209.85.135.104/search?q=cache:zRNh4IL9jccJ:ec.europa.eu/enterprise/library/enterpriseurope/issue18/articles/en/topic2_en.htm+european+cost+of+pv+panels&hl=it&ct=clnk&cd=3&gl=it)
- [105] Dr. N. Lymberopoulos, Hydrogen Production From Renewables, September 2005 available on: [http://ec.europa.eu/energy/res/sectors/doc/polygeneration/res\\_hydrogen\\_study\\_final.pdf](http://ec.europa.eu/energy/res/sectors/doc/polygeneration/res_hydrogen_study_final.pdf)
- [106] Mark A. Bernstein, RAND Forum on Hydrogen Technology and Policy, A Conference Report, December 2004, available on:  
[http://www.cleanfuelcellenergy.com/RAND\\_CF218.pdf](http://www.cleanfuelcellenergy.com/RAND_CF218.pdf)

## **Životopis**

Antoine Busuttil je rođen 5. studenog 1979. na Malti. Nakon završenog osnovnog obrazovanja upisuje se na Sveučilište u Malti gdje 2003. stječe zvanje diplomiranog inženjera elektrotehnike (Bachelors). Za vrijeme školovanja radio je u raznim energetske tvrtkama na Malti i u inozemstvu.

Godine 2004. upisuje studij Sustainable Energy Engineering na Fakultetu strojarstva i brodogradnje, Sveučilištu u Zagrebu gdje se specijalizira za područje održive energetike u kojem među ostalim analizira razne scenarija razvoja energetske sustava otoka Malte. Sudjelovao je u pisanju nekoliko znanstvenih članaka i radova od kojih su neki objavljeni u International Journal of Hydrogen Energy.

Antoine Busuttil je u svojoj karijeri bio na pozicijama projekt menadžera te je radio na nekolicini projekata na Malti i u inozemstvu (u zemljama sjeverne Afrike i u Europi). Trenutno radi za talijansku kompaniju na međunarodnim poslovima. Aktivni je član Malteške komore inženjera u kojoj se bavi dobrotvornim radom i aktivnostima vezanim uz prikupljanje financijskih sredstava.

## **Biography**

Ing. Antoine Busuttil was born on the 5<sup>th</sup> November 1979 in Malta. After obtaining his education in Malta he enrolled at the University of Malta where he obtained his Bachelors degree in Electrical Engineering in year 2003. During this study he worked in various Power Generating Utilities and companies as an apprentice both locally and Internationally.

In year 2004 he furthered his studies by reading for a Masters of Science in Sustainable Energy Engineering at the University of Zagreb specialising in Sustainable Power Generation during which he analysed and studied various Energy Scenarios for the Island of Malta. Various scientific articles and papers were written and published, one of which presented at the International Journal of Hydrogen.

During his work career Ing. Busuttil occupied various Project management positions, working both locally and Internationally namely North African countries and Europe. He is currently working with an Italian company occupying an International position. He is also a member of the Malta Chamber of Engineers and actively involves himself in charitable and fund raising activities.